

Assembly Instructions

Mobile Hygiene Shield MHS



Lifetime
Warranty



Quantity
Discounts







Assembled
in USA

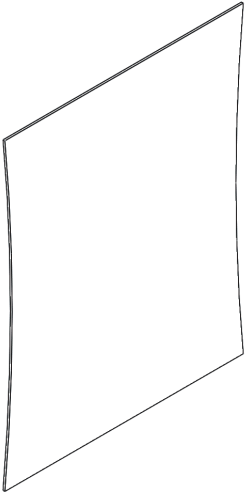
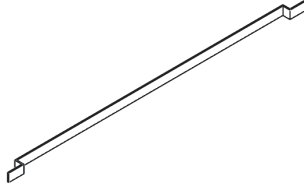

Fast
Shipping

Hardware & Part List

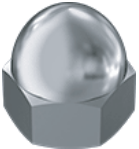
<p>Upright Extension</p>  <p>Qty: 2</p>	<p>Acrylic Shield</p>  <p>Qty: 1</p>	<p>Shield Bracket</p>  <p>Qty: 2</p>	<p>Hex Machine Screw</p>  <p>Qty: 4</p>
		<p>Cross Bar</p>  <p>Qty: 1</p>	<p>Phillips Bolt</p>  <p>Qty: 10</p>
	<p>Casters</p>  <p>Qty: 4</p>	<p>Jam Nut</p>  <p>Qty: 4</p>	<p>Cap Nut</p>  <p>Qty: 6</p>



Lifetime
Warranty



Quantity
Discounts



Assembled
in USA



Fast
Shipping

1

Attach Casters to the Upright Extension as shown, using the Jam Nuts to ensure Casters are level. Repeat this step on the other side.

Castors



Qty: 4

Jam NUTs



Qty: 4

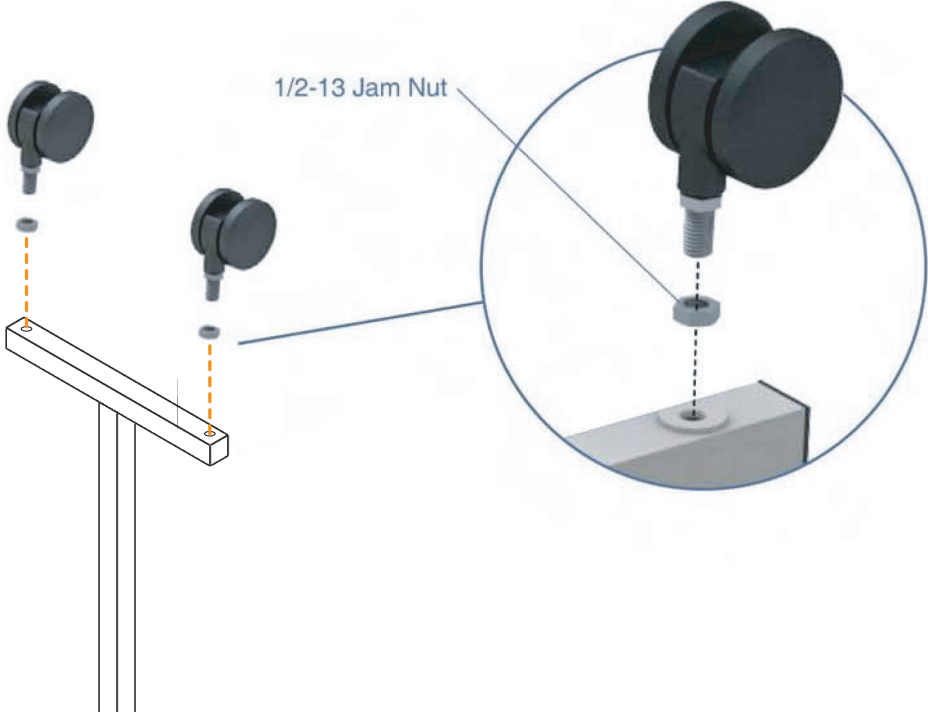

2

Attach the Cross Bar to the Upright extension by inserting the Hex Machine Screw through the Cross Bar and into the threaded inserts in the Upright Extension. Repeat this step on the other side.

Hex Machine Screw



Qty: 4

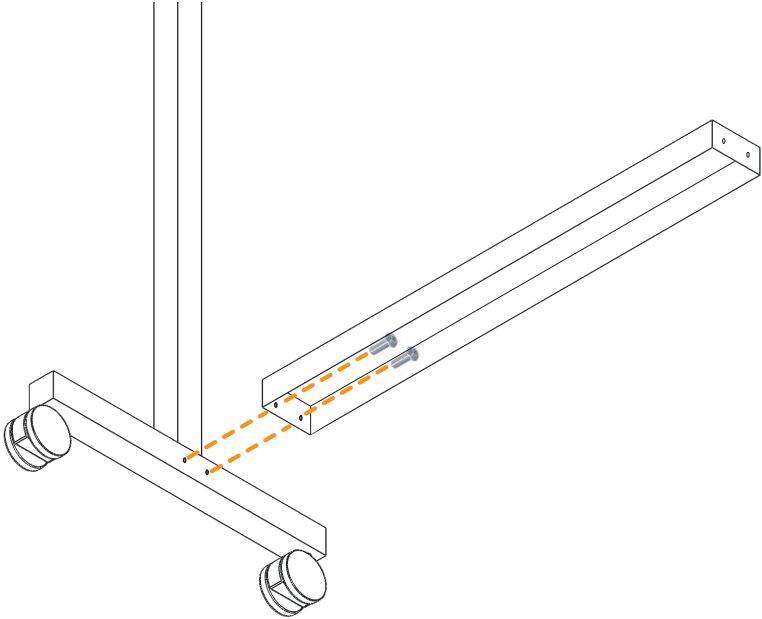

Lifetime Warranty



Quantity Discounts



Assembled in USA



Fast Shipping

3

Attach the Shield Brackets to the Upright extension by inserting the Phillips Bolts through the Shield Brackets and into the threaded inserts in the Upright Extension.

Phillips Bolt



Qty: 4

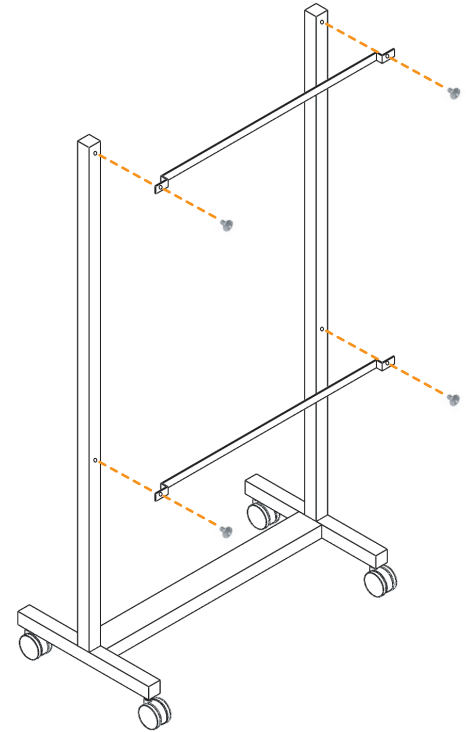

4

Attach the Acrylic Shield to the Shield Brackets by inserting the Phillips Bolts through the Acrylic Shield and Shield Brackets. Once in place, attach the Cap Nuts to the Phillips Bolts from the other side and tighten the Acrylic Shield in place.

Phillips Bolt



Qty: 6

Cap Nut



Qty: 6

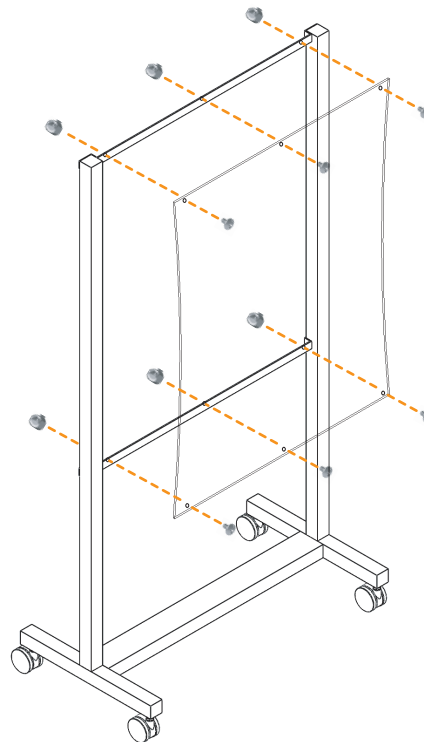

Lifetime
Warranty



Quantity
Discounts



Assembled
in USA



Fast
Shipping