

DESKTOP SNEEZE GUARD

DSKTP-SNZ-3x2x1

The Desktop Sneeze Guard is a polished and professional looking extrusion-based sneeze guard featuring clear, 1/8" plexiglass and silver, aluminum extrusion around the perimeter of the frame. It is designed to help prevent the spread of germs, splashes and sprays. Superior quality. Made in the USA.

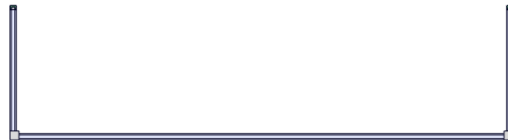
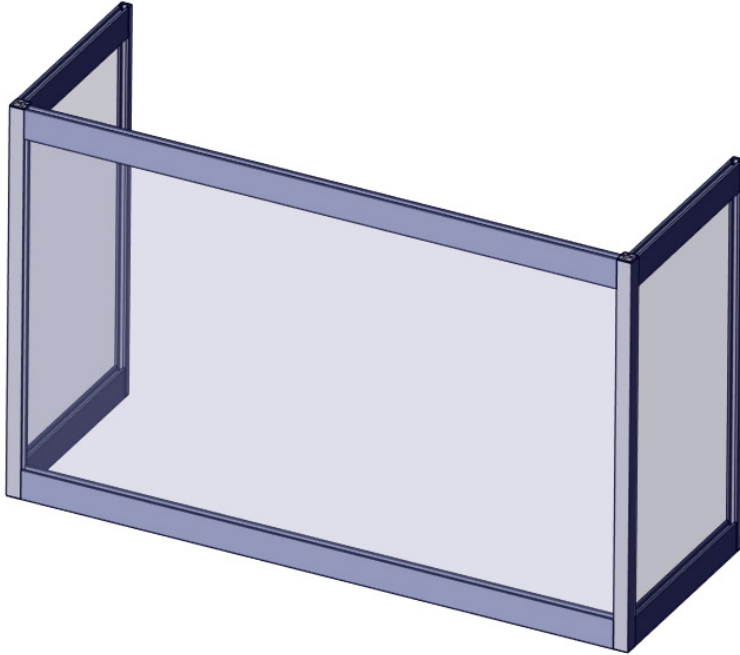

features and benefits:

- Clear, 1/8" (3mm) thick plexiglass dividers held in place by 15mm extrusion that sits on desk
- Frame is lightweight anodized aluminum extrusion
- Easy to assemble
- can be used as a pull cart-
- kit includes cart, graphic, one shelf and carry bag
- Extrusions can be recycled
- One year limited hardware warranty against manufacturer defects

dimensions:

Hardware

Assembled unit:
37.15" w x 23.66" h x 13.06" d
944mm(w) x 601mm(h) x 332mm(d)

Approximate weight with cases:
12 lbs / 6 kgs

Shipping

Packing case(s):
2 Box

Shipping dimensions:
N/A

Approximate total shipping weight:
N/A



WARNING: Cancer
www.P65Warnings.ca.gov



This product may include the following materials for recycle:
aluminum, select wood, fabric, cardboard, paper, steel, and plastics.

We are continually improving and modifying our product range and reserve the right to vary the specifications without prior notice. All dimensions and weights quoted are approximate and we accept no responsibility for variance. E&OE. See Graphic Templates for graphic bleed specifications.

ASSEMBLE FRAME

*Not to scale

INCLUDED IN YOUR KIT:

x2

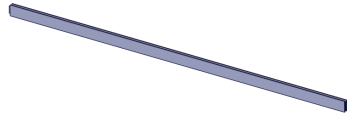

PH-900-L-L

x4



PH-300-L-L

x2



PE-600

x2



P90S-600

x1



5MM ALLEN KEY

x1



PLEX-3MM-CLR-906-522

x2

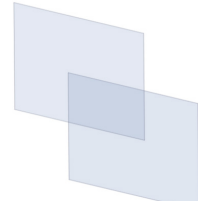

PLEX-3MM-CLR-306-522

x2



CP90S-GRAY

EXPLODED VIEW:

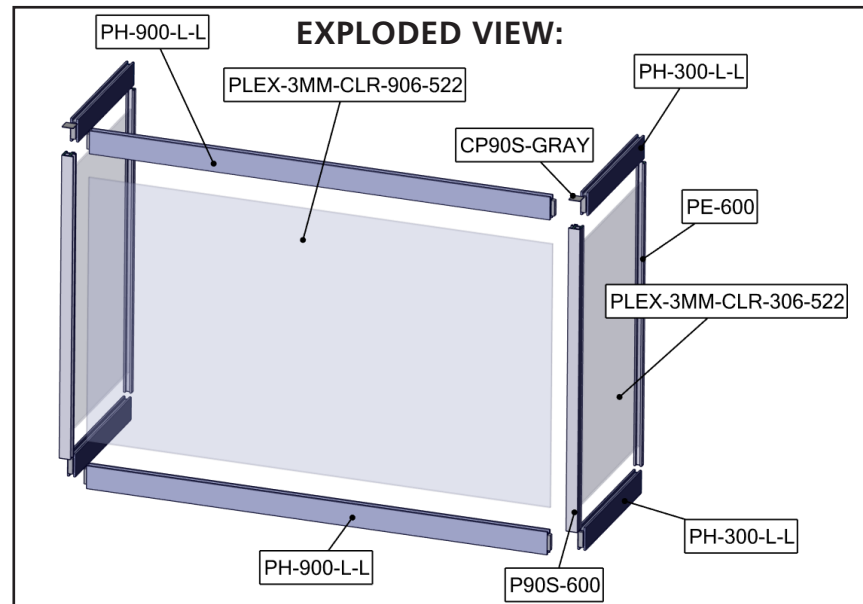

STEP 1:

Gather the components to build STEP 1. Use the Exploded View and the Labeling Diagram for part labels. Do not over tighten.

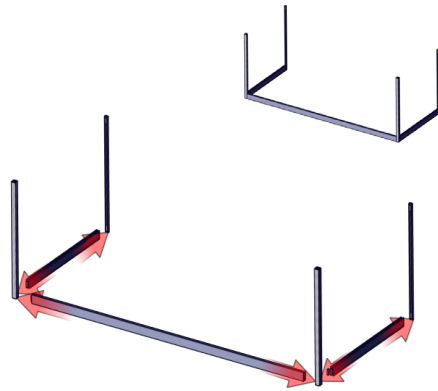
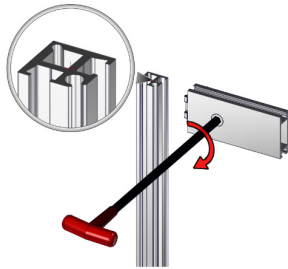

STEP 2:

Gather the plex infill to complete STEP 2. Use the Exploded View and the Labeling Diagram for part labels.

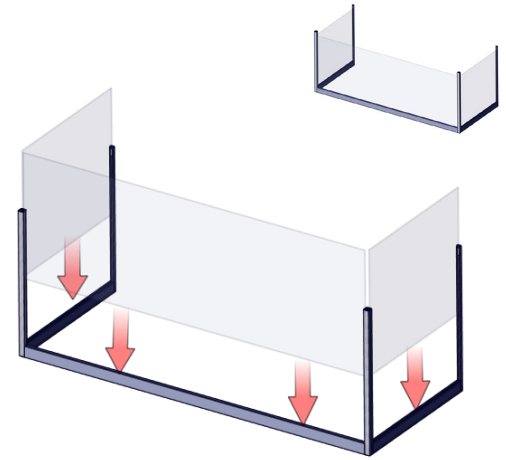
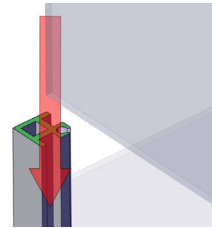

STEP 3:

Gather the components to build STEP 2. Use the Exploded View and the Labeling Diagram for part labels. Do not over tighten PH.

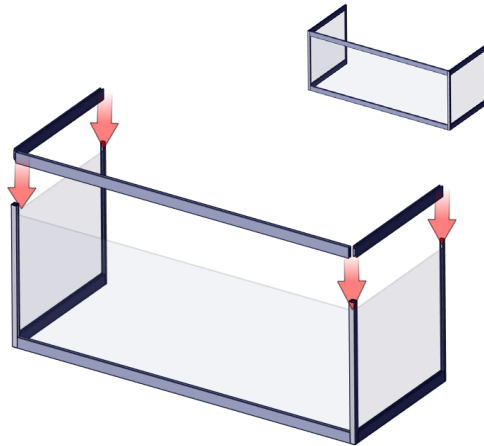
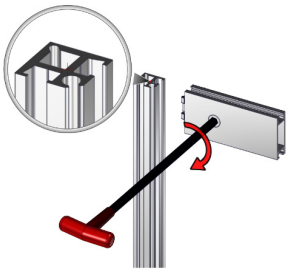

STEP 4:

Gather CP90S caps connect them to the 2 P90S-600 to finish the setup.

