

Hybrid Pro 10FT Modular Backwall Kit 34

HP-K-34

Create a commanding presence with the Hybrid Pro™ Modular Kit 34 10ft x 10ft display. This exhibit kit combines fabric, form and function! Seamless, pushfit SEG fabric graphics gives real estate for powerful branding and messaging. The aluminum frame system is strong, durable and recyclable; it comes with a lifetime warranty. A 36" w x 47" h laminate slotwall panel provides the opportunity to put merchandise or promotional items on display. Add a 50" or smaller monitor to share videos and other dynamic content.

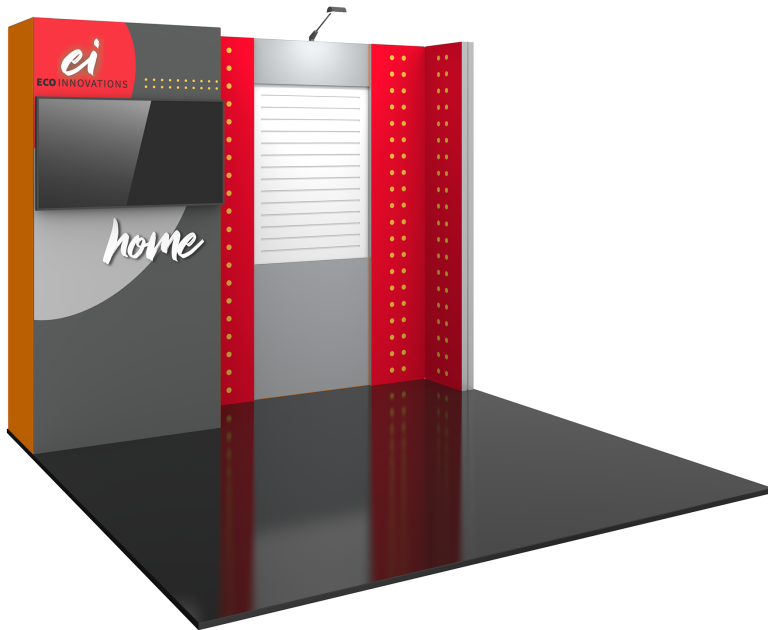

We are continually improving and modifying our product range and reserve the right to vary the specifications without prior notice. All dimensions and weights quoted are approximate and we accept no responsibility for variance. E&OE. See Graphic Templates for graphic bleed specifications

6/20/2024

features and benefits:

- Silver aluminum extrusion frames
- Laminate slot wall panel for merchandise display
- 7 single-sided SEG dye-sublimated push-fit fabric graphics
- Medium monitor bracket holds 50" or smaller monitor & 40 lbs. max weight
- 1 Lumina 200 LED floodlight, straight arm and adjustable head, black finish, 19.5" from end to end
- Cases included: OCFM (1) & OCH2 (2)
- Lifetime hardware warranty against manufacturer defects

*Monitors not included

dimensions:

Hardware

Assembled unit:

119.09" w x 94.50" h x 24.04" d
3025mm(w) x 2400mm(h) x 611mm(d)

Approximate Weight:
289 lbs / 132 kg

Graphics

Refer to related graphic templates for more information Visit:

<https://www.theexhibitorshandbook.com/downloads/download-graphic-templates> or click here

Shipping

Packing case(s):

1 OCFM
2 OCH2

Shipping dimensions:

OCFM:
(38" W x 15" H x 49" D)
965mm(l) x 381mm(h) x 1245mm(d)

OCH2:
(52" L x 29" H x 15" D)
1321mm(l) x 737mm(h) x 381mm(d)

Approximate shipping weight:
379 lbs / 172 kg

additional information:

Graphic material:

Dye-sublimation SEG push-fit fabric

Slotwall Panel Colors:



Dove
Grey

Black

Designer
White

Fusion
Maple

2 person assembly recommended:



This product may include the following materials for recycle: aluminum, select wood, fabric, cardboard, paper, steel, and plastics.

HP-K-34

SETUP INSTRUCTIONS

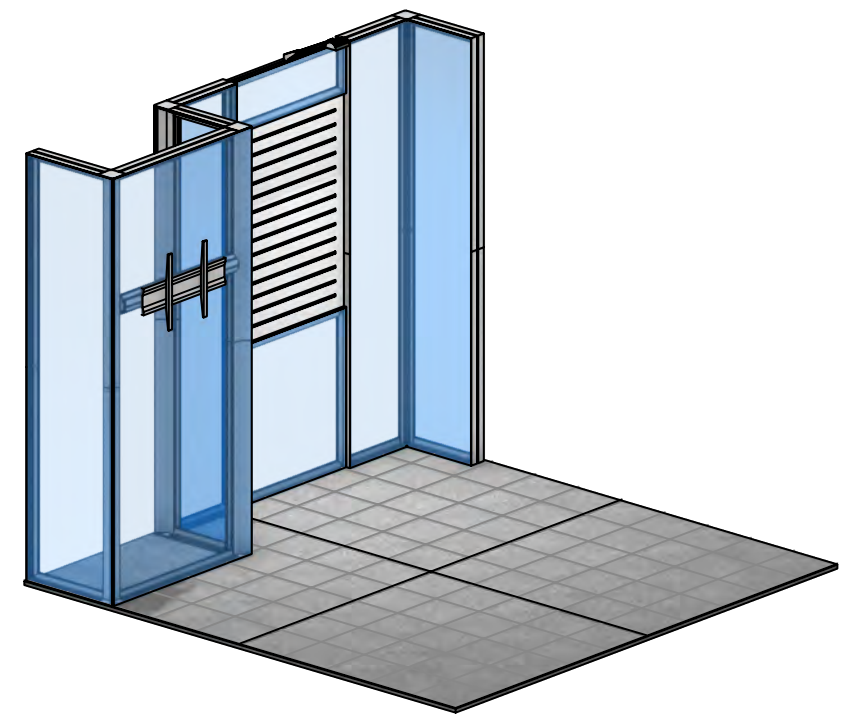
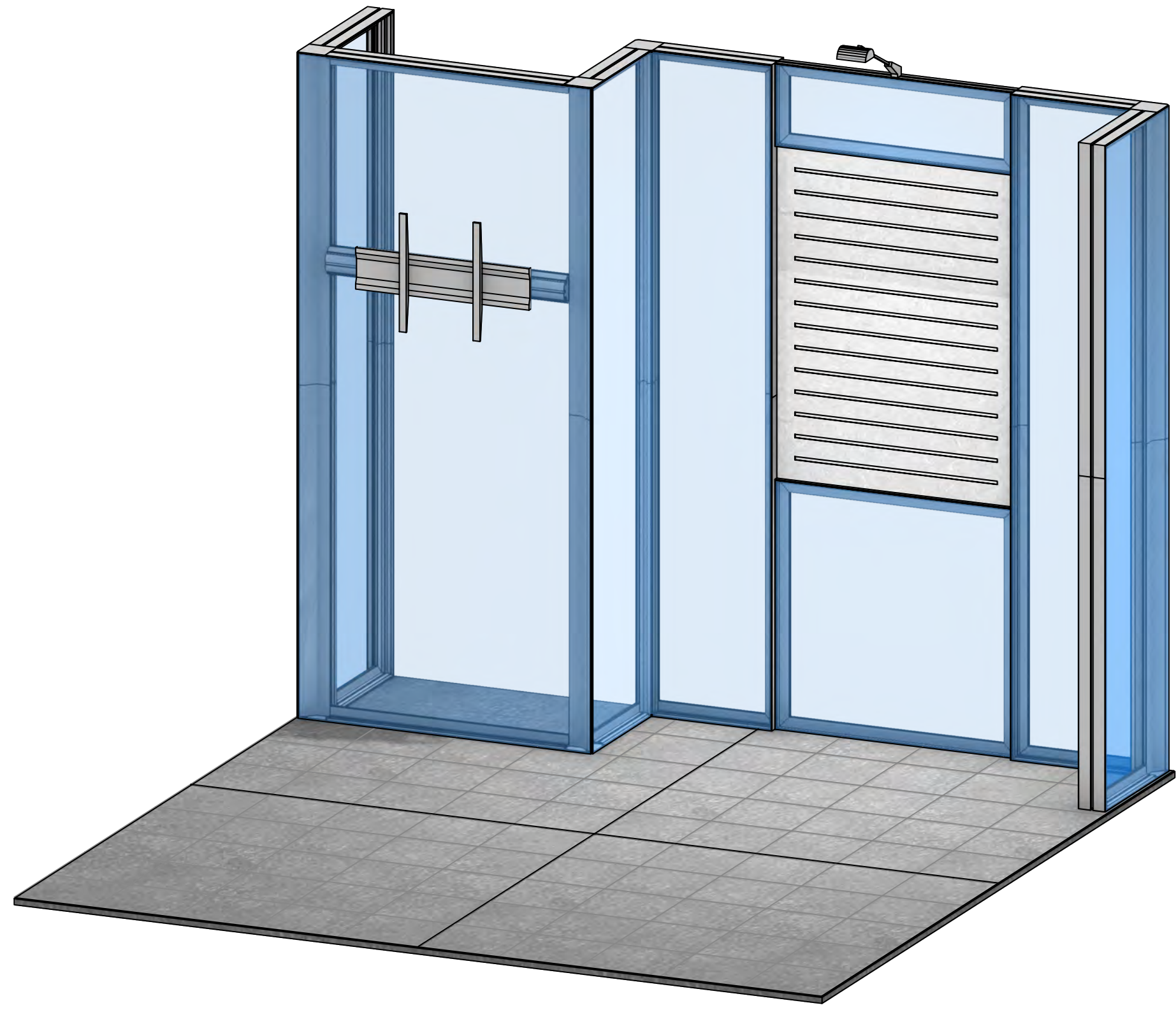

PROJECT BOM

SETUP#	HARDWARE	#	DESCRIPTION
A1	102-600	4	600MM LENGTH OF PH2 EXTRUSION
A2	242-900-01-01	1	900MM LENGTH OF PM4R8-WITH CAM LOCKS BOTH ENDS
A3	320-300-03-03-06	2	300MM LENGTH OF PHFC2 EXTRUSION-WITH MITRE CUT BOTH ENDS-WITH SIDE LOCKS
A4	320-900-03-03	4	900MM LENGTH OF PHFC2 EXTRUSION-WITH MITRE CUT BOTH ENDS
A5	320-900-03-03-06	2	900MM LENGTH OF PHFC2 EXTRUSION-WITH MITRE CUT BOTH ENDS-WITH SIDE LOCKS
A6	340-400-01-01	2	400MM LENGTH OF PHFC4 EXTRUSION-WITH CAM LOCKS BOTH ENDS
A7	340-450-01-03	6	450MM LENGTH OF PHFC4 EXTRUSION-WITH CAM LOCK 1 END-MITRE CUT 1 END
A8	340-505-01-03	2	505MM LENGTH OF PHFC4 EXTRUSION-WITH CAM LOCK 1 END-MITRE CUT 1 END
A9	340-900-01-01	2	900MM LENGTH OF PHFC4 EXTRUSION-WITH CAM LOCKS BOTH ENDS
A10	340-1200-02-03	8	1200MM LENGTH OF PHFC4 EXTRUSION-WITH MITRE CUT FOR CB9 ONE END-IB2 LOCK HOLE ONE END
A11	342-1193-10-10	8	1193MM OF PMFC4-90-B EXTRUSION -WITH STOPS AT 315MM
CB9	CB9	16	90 DEGREE JOINER
EXT-LG-MB	EXT-LG-MB	1	Large LCD Monitor mount, 37" - 70" size, 110 Lb. max. weight, Tilting-with extrusion mounted hardware
IB2-O	IB2-O	4	JOINER BAR (OLD STYLE)
A12	LP-PS-900-1200	1	900MM W X 1200MM H LOCK SLOTWALL PANEL
LUM-LED2-ORL-B	LUM-LED2-ORL-B	1	25 WATT BLACK LED STEM LIGHT (REPLACES 200 W HALOGEN)
PMFC4-90-B-CAP	PMFC4-90-B-CAP	8	PLASTIC MOLDED END CAP FOR THE PMFC4-90-B EXTRUSION
SETUP#	GRAPHICS	#	DESCRIPTION
GR-A	HP-34-A-G	1	GRAPHIC (A) (27.82 w X 98.37 h total size) 23.82 w X 94.37 h finish size, Dye-sub print on Eclipse Blockout Stretch, single sided, sewn with FCE-2 silicone beading around perimeter & pull tab in bottom right corner
GR-B	HP-34-B-G	1	GRAPHIC (B) (47.46 w X 98.37 h total size) 43.46 w X 94.37 h finish size, Dye-sub print on Eclipse Blockout Stretch, single sided, sewn with FCE-2 silicone beading around perimeter & pull tab in bottom right corner
GR-C	HP-34-C-G	1	GRAPHIC (C) (23.92 w X 98.37 h total size) 19.92 w X 94.37 h finish size, Dye-sub print on Eclipse Blockout Stretch, single sided, sewn with FCE-2 silicone beading around perimeter & pull tab in bottom right corner
GR-D	HP-34-D-G	1	GRAPHIC (D) (21.87 w X 98.37 h total size) 17.87 w X 94.37 h finish size, Dye-sub print on Eclipse Blockout Stretch, single sided, sewn with FCE-2 silicone beading around perimeter & pull tab in bottom right corner
GR-E	HP-34-E-G	1	GRAPHIC (E) (39.31 w X 15.69 h total size) 35.31 w X 11.69 h finish size, Dye-sub print on Eclipse Blockout Stretch, single sided, sewn with FCE-2 silicone beading around perimeter & pull tab in bottom right corner
GR-F	HP-34-F-G	1	GRAPHIC (F) (39.31 w X 39.31 h total size) 35.31 w X 35.31 h finish size, Dye-sub print on Eclipse Blockout Stretch, single sided, sewn with FCE-2 silicone beading around perimeter & pull tab in bottom right corner
GR-G	HP-34-G-G	1	GRAPHIC (G) (21.87 w X 98.37 h total size) 17.87 w X 94.37 h finish size, Dye-sub print on Eclipse Blockout Stretch, single sided, sewn with FCE-2 silicone beading around perimeter & pull tab in bottom right corner
GR-H	HP-34-H-G	1	GRAPHIC (H) (21.87 w X 98.37 h total size) 17.87 w X 94.37 h finish size, Dye-sub print on Eclipse Blockout Stretch, single sided, sewn with FCE-2 silicone beading around perimeter & pull tab in bottom right corner
GR-I	HP-34-I-G	1	GRAPHIC (I) (25.65 w X 98.37 h total size) 21.65 w X 94.37 h finish size, Dye-sub print on Eclipse Blockout Stretch, single sided, sewn with FCE-2 silicone beading around perimeter & pull tab in bottom right corner

FABRIC, VINYL & UV GRAPHIC CARE GUIDELINES

GENERAL HANDLING FABRIC GRAPHICS

- Your fabric graphics should always be handled in a clean and dry area with clean hands. When possible, use white fabric gloves.
- Be sure fabric is clean and dry before packing.
- Machine washing and/or drying is not recommended for all fabrics. Refer to the chart below for which fabrics are washable.

EMERGENCY STAIN TREATMENT (FABRIC)

- For dry stains, like loose dirt or pencil marks, try initially using masking tape or Magic Eraser (dry-not moistened).
- Introduce water or liquids to treat stains, if at all possible, treat the stain with fabric off of the frame.

- Place a clean dry cloth behind stain (to absorb stains while being treated). Moisten another cloth initially with just water (distilled water is optimal, if available).
- Gently blot stain with moistened cloth (or small area of moistened Magic Eraser), while trying to push stain through to the back, using the dry cloth to absorb.
- Repeat using care to keep the wet area as small as possible.
- Grandma's Secret Spot remover can be an effective stain remover. Mix several drops in a small cup with clean water. Repeat above and using dry cloth on back of stain to absorb.

MACHINE WASHING FABRIC GRAPHICS

- Cold water/delicate cycle/tumble dry low or air dry. For stretch fabrics do not use dryer, let hang dry.
- Use caution on dryer time with graphics containing liners. It's best to put tension fabric on frame when fabric is still damp and let it air dry. Always be sure that the aluminum frame is clean when mounting the damp graphic.
- Fabric stretch graphics that are washed and machine dried may shrink up to 3/4" per every 50" of fabric in the direction of the stretch and shrink up to 1/4" in non stretch direction.

STORING & PACKING BACKLIT GRAPHICS

- To avoid cracks in the ink or having to steam graphics, Backlit fabrics should be loosely folded with bubble wrap or stored around a tube.
- Avoid folding the graphic tightly to store in a small bag or box.

GENERAL HANDLING VINYL & UV GRAPHICS

- Vinyl banners and rigid graphics should always be handled in a clean and dry area with clean hands. When possible, use white fabric gloves.
- Be sure vinyl/ UV is clean and dry before packing. Always follow material handling and packing instructions included.
- All vinyl material should be rolled with graphic facing in to protect the graphic printed side. Roll on a tube if available.
- Avoid folding material to reduce the risk of crease lines and chipped inks. If a graphic must be folded, try and fold loosely and as few times as possible.

EMERGENCY STAIN TREATMENT (UV)

- For dry stains, like loose dirt, pencil marks or adhesive, try initially using masking tape, Masking tape can be quite effective at lifting dry surface dirt. Try 'pulling' as much of stain away as you can and avoid rubbing the stain into the material.
- While using Windex® avoid scrubbing harshly. Too much pressure can fade the graphic print.

GENERAL HANDLING OF ROLLABLE PVC PANELS

All mural panels, truss panels and detachables should be rolled with the graphic facing out to protect the graphic printed side. Mural panels should be stored in the original plastic sleeves that are provided with the panels.

STEAMING FABRIC GRAPHICS

- For optimal results, steam wrinkles when fabric is tensioned and installed securely on the frame.
- Fill steamer with clean drinking water or distilled water. Avoid using water containing hard minerals.
- Hold steamer upright and hold close to fabric. Avoid touching fabric with steamer.
- Do not tap steamer as water drips may cause water marks to form on graphic

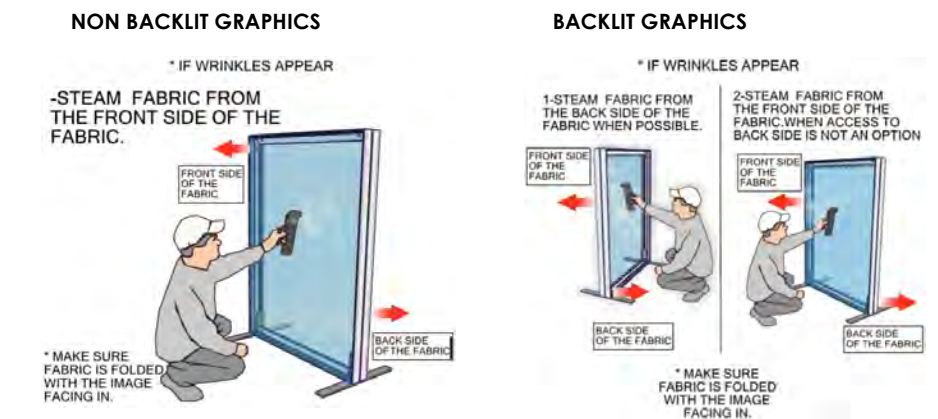

FABRIC	WASHING MACHINE	DRY CLEAN	SPOT CLEAN	STEAMING / IRON	MAGIC ERASER
RESILIENCE	NO	NO	NO	NO	YES (ONLY ON WHITE)
OXFORD	YES	YES	YES	YES	YES
POWER STRETCH	YES	YES	YES	YES	YES
DISPLAY POLYESTER	YES	YES	YES	YES	YES
DISPLY POLY TABLE THROWS	YES	YES	YES	YES	YES
OUTDOOR FLAG	YES (MUST VELCRO THE TABS)	N/A (MUST VELCRO THE TABS)	YES	YES	YES
CANVAS OUTDOOR	NO	NO	YES	STEAM ONLY	YES
CANVAS LIGHTBOX	NO	NO	NO	STEAM ONLY	YES
AGILITY	YES	YES	YES	(ONLY W/ 100% TENSION)	YES
SUPER STRETCH	YES	YES	YES	(ONLY W/ 100% TENSION)	YES
TRIPLE WHITE	YES	YES	NO	YES	NO
ECLIPSE	NO	NO	YES	STEAM ONLY	YES
SOFT KNIT	YES	YES	YES	YES	YES
SHEER	YES	YES	YES	YES	YES
VINYL & ROLLABLE					
	SOLVENT	SOAPY WATER (Dawn)	WINDEX		
FLATMAXX	ONLY ON WHITE	YES	NO		
SCRIM 13OZ/ 18OZ	ONLY ON WHITE	YES	NO		
VINLY 20OZ	ONLY ON WHITE	YES	NO		
MELINEX	NO	YES	NO		
MURAL PANELS	NO	YES	YES		
UV RIDGED	NO	YES	YES		

SETUP NOTES

Redesign of this exhibit without approval by Orbus may result in dangerous and unsafe structures. Nimlok disclaims any responsibility for redesigned exhibits it does not approve in writing.





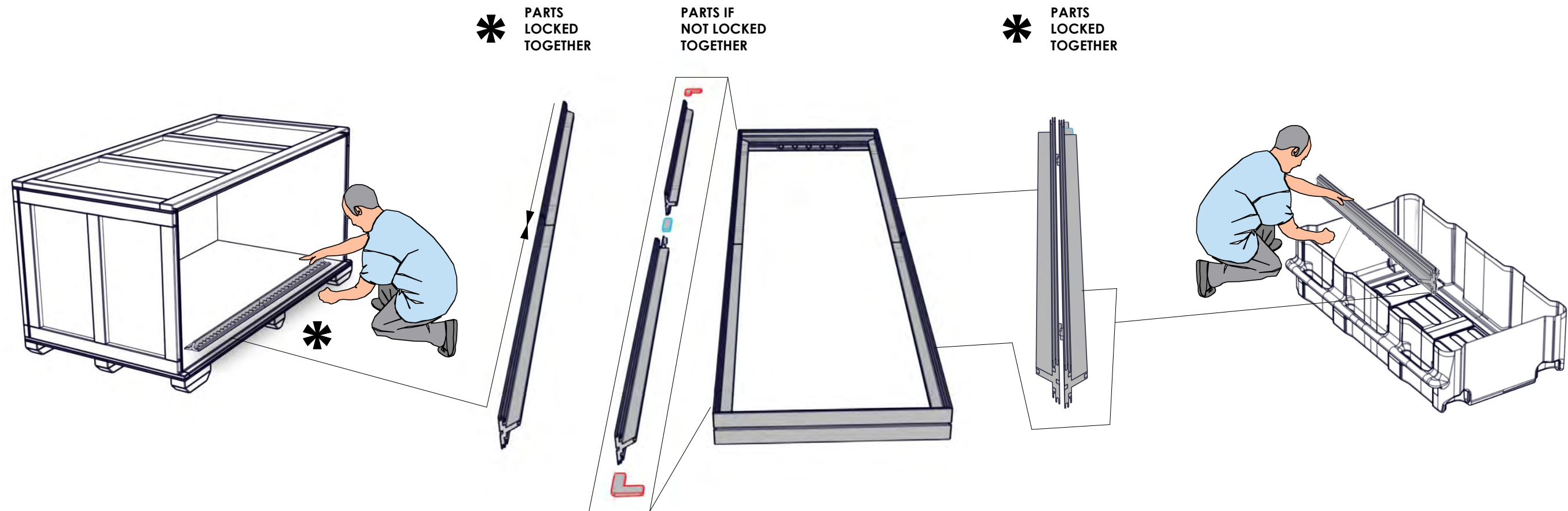

Parts and components such as panels and extrusions are manufactured to metric sizing. Where ever possible sizes have been noted in feet and inches as well as in metric. Below is the imperial to metric sizing table for reference. "Nominal" refers to approximate size.

NOTE: PARTS MAY COME PRE-ASSEMBLED FOR PACKING PURPOSES.



METRIC TO IMPERIAL DIMENSION

2400mm = (94.50")	1200mm = (47.25")
2100mm = (82.67")	900mm = (35.43")
1800mm = (70.87")	600mm = (23.62")
1500mm = (59.05")	300mm = (11.81")

-  Internet Connection
  Phone Line
-  Main Electric Drop (Point Of Distribution)
-  Electrical Outlet
  Sharp Edges
-  Cables Under Carpet

HELPFUL SETUP QR CODES



**SCAN QR CODES
WITH YOUR PHONE
CAMERA**

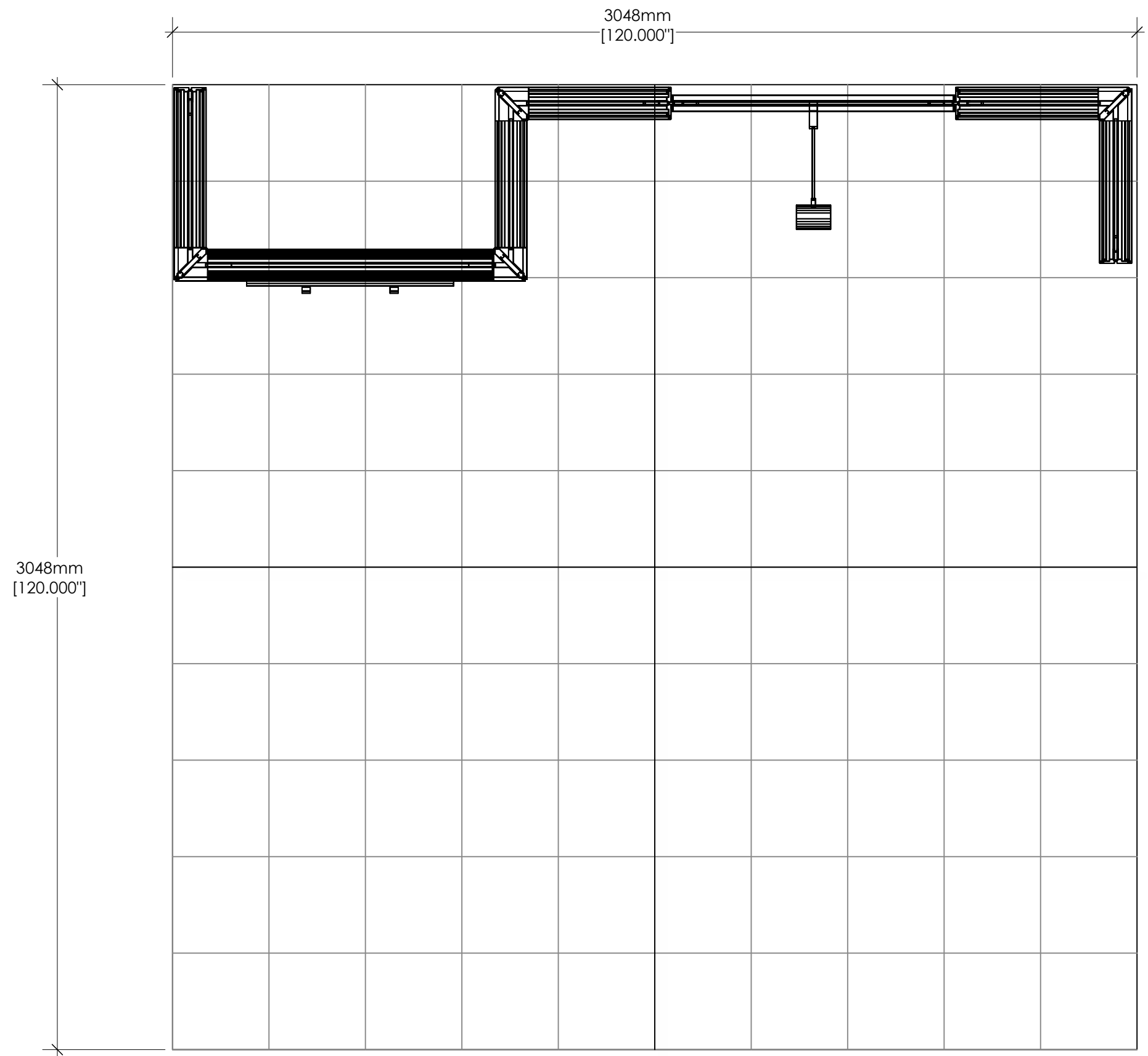

2400mm
[94.488"]

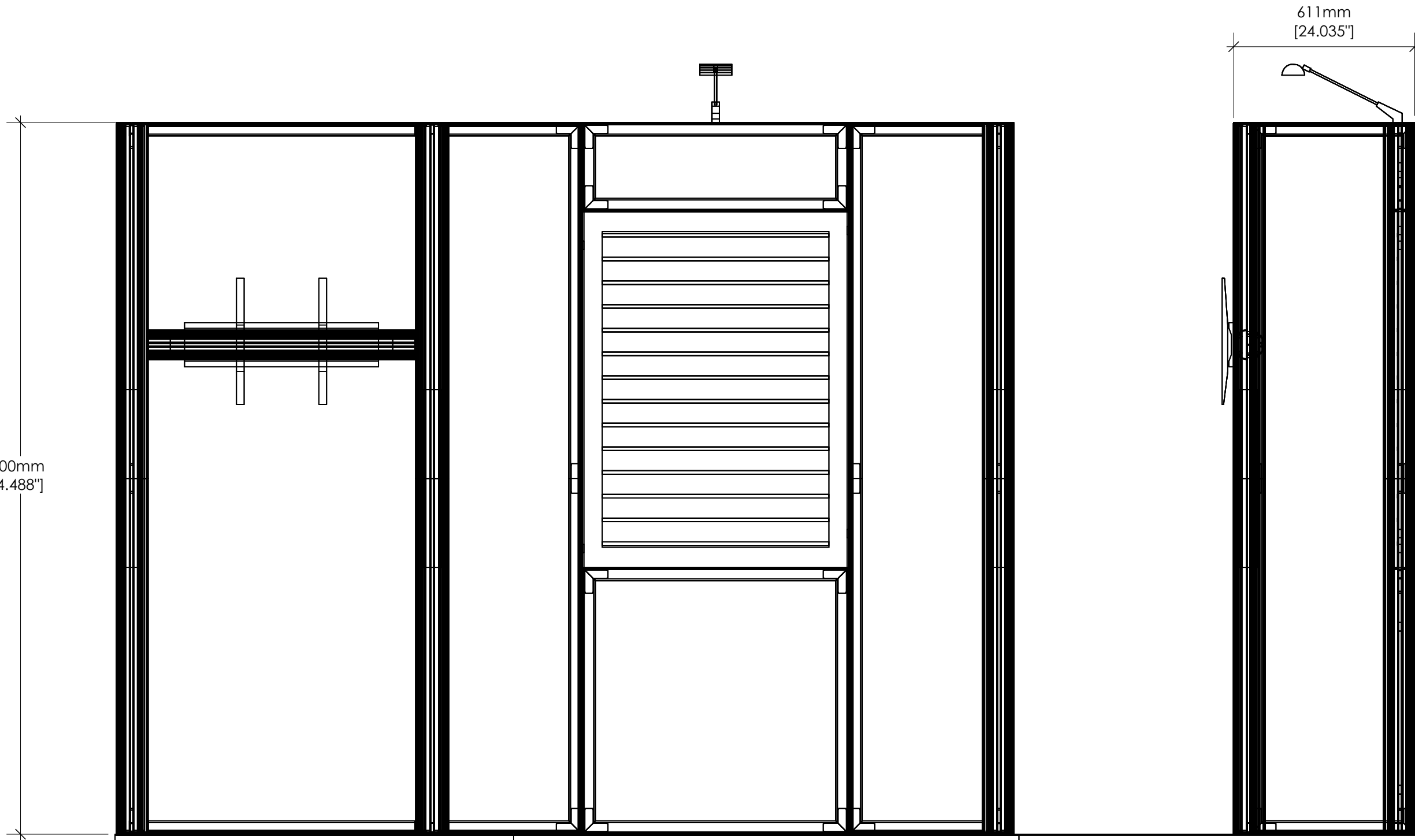

611mm
[24.035"]

SETUP#	#	DESCRIPTION
PMFC4-90-B-CAP	2	PLASTIC MOLDED END CAP FOR THE PMFC4-90-B EXTRUSION
A11	2	1193MM OF PMFC4-90-B EXTRUSION -WITH STOPS AT 315MM
A1	1	600MM LENGTH OF PH2 EXTRUSION
A8	2	505MM LENGTH OF PHFC4 EXTRUSION-WITH CAM LOCK 1 END-MITRE CUT 1 END
CB9	2	90 DEGREE JOINER
A10	2	1200MM LENGTH OF PHFC4 EXTRUSION-WITH MITRE CUT FOR CB9 ONE END-IB2 LOCK HOLE ONE END
IB2-O	1	JOINER BAR (OLD STYLE)

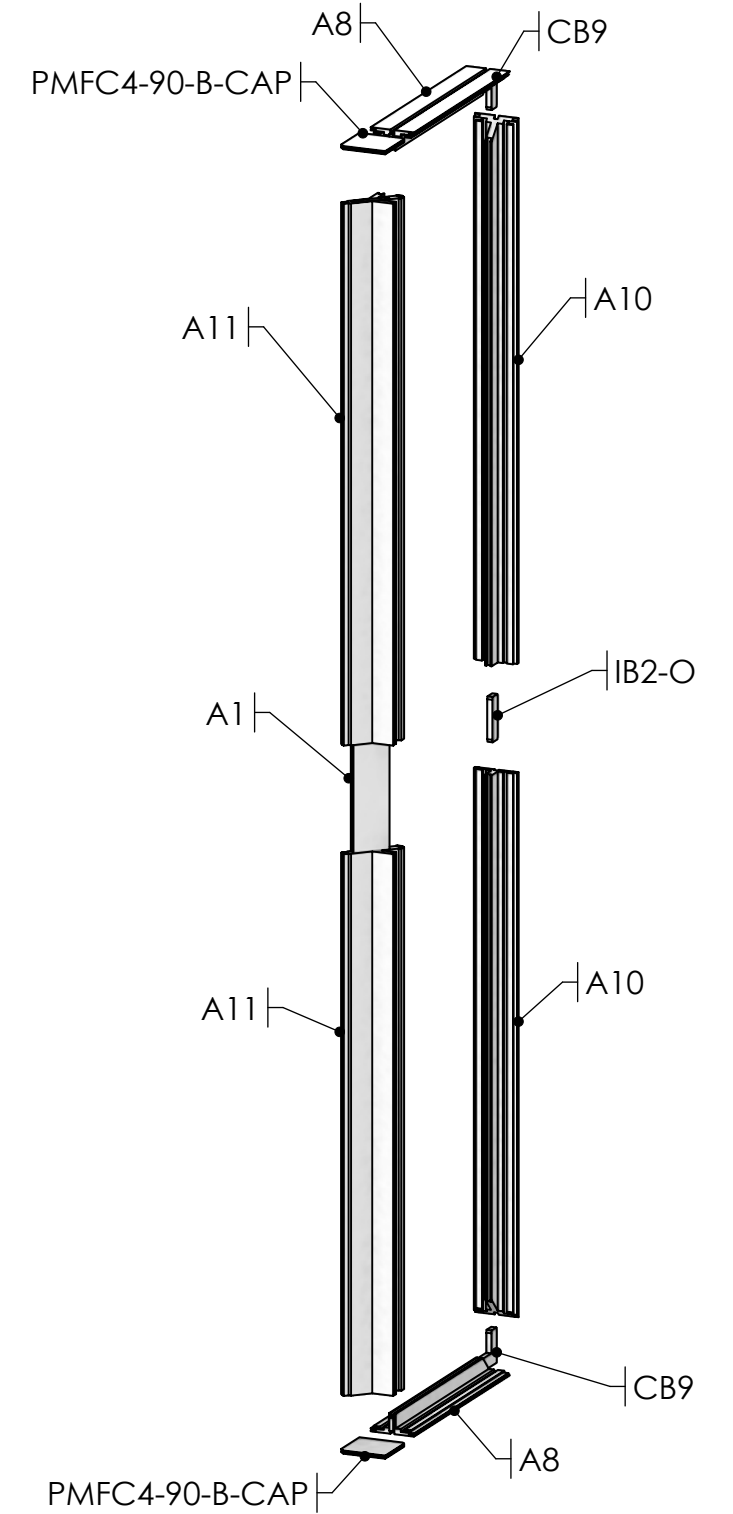
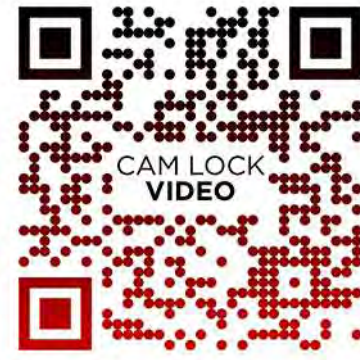
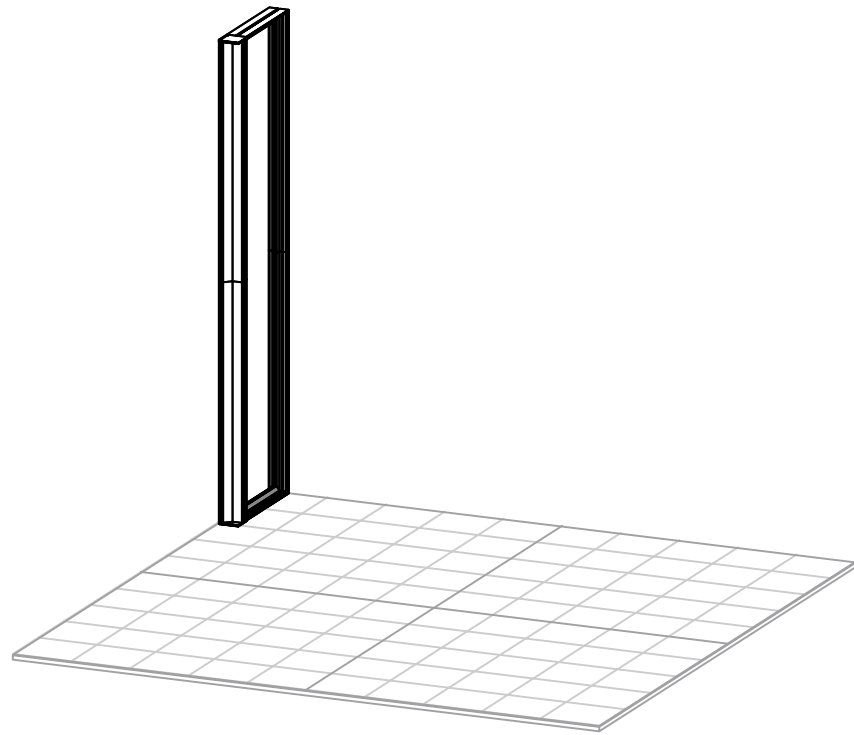
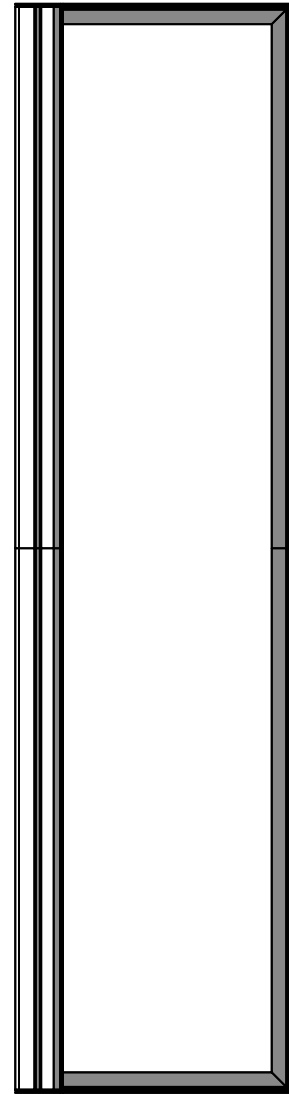

COMPONENTS
IN THIS STEP:
(Not to scale)

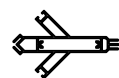

342 (90B)



340 (PHFC4)

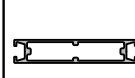

102 (PH2)

SETUP#	#	DESCRIPTION
PMFC4-90-B-CAP	2	PLASTIC MOLDED END CAP FOR THE PMFC4-90-B EXTRUSION
A11	2	1193MM OF PMFC4-90-B EXTRUSION -WITH STOPS AT 315MM
A1	1	600MM LENGTH OF PH2 EXTRUSION
A9	2	900MM LENGTH OF PHFC4 EXTRUSION-WITH CAM LOCKS BOTH ENDS
A2	1	900MM LENGTH OF PM4R8-WITH CAM LOCKS BOTH ENDS

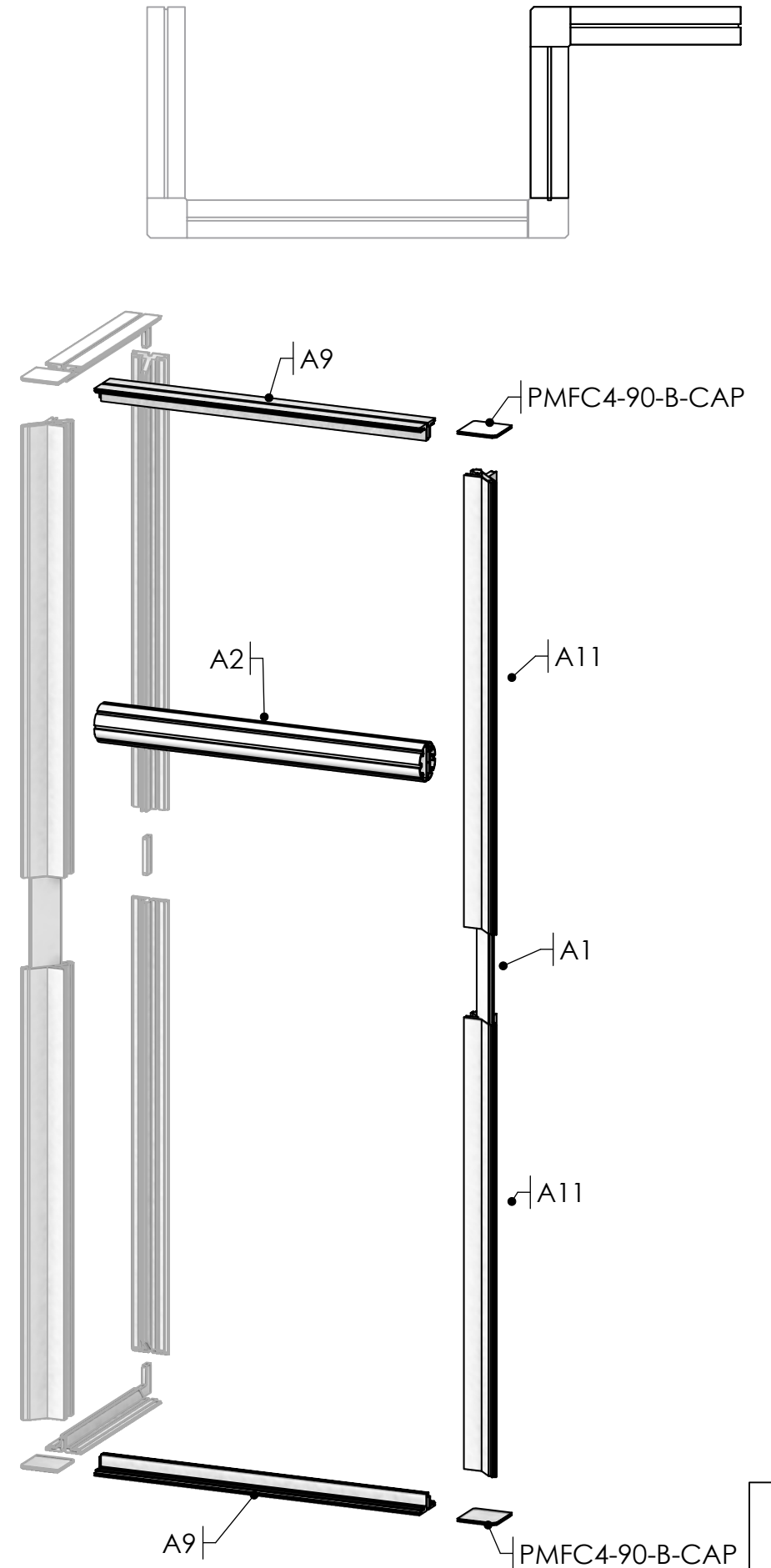
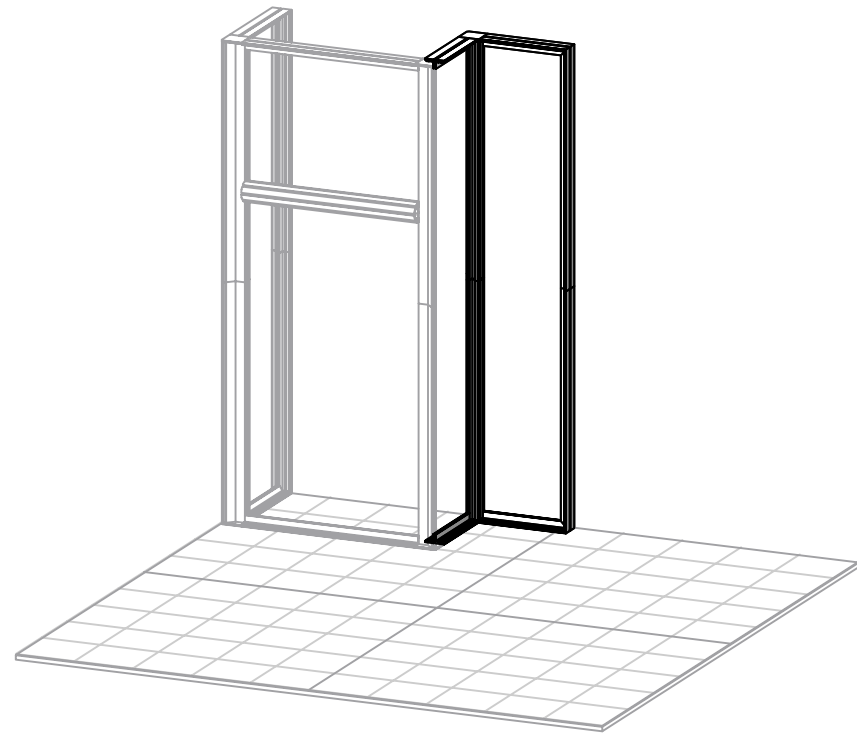
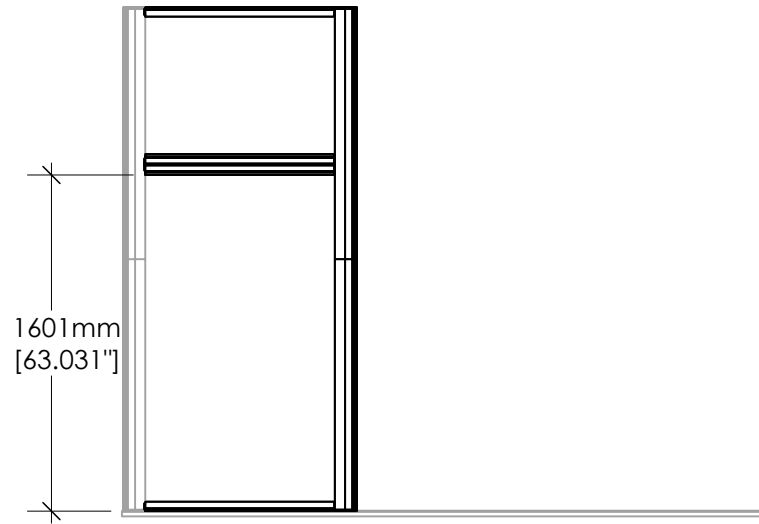

COMPONENTS
IN THIS STEP:
(Not to scale)

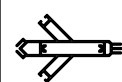

342 (90B)

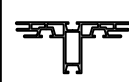

340 (PHFC4)

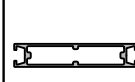

102 (PH2)



242 (PM4R8)

SETUP#	#	DESCRIPTION
PMFC4-90	2	PLASTIC MOLDED END CAP FOR THE PMFC4-90-B EXTRUSION
A11	2	1193MM OF PMFC4-90-B EXTRUSION -WITH STOPS AT 315MM
A1	1	600MM LENGTH OF PH2 EXTRUSION
A6	2	400MM LENGTH OF PHFC4 EXTRUSION-WITH CAM LOCKS BOTH ENDS
A7	2	450MM LENGTH OF PHFC4 EXTRUSION-WITH CAM LOCK 1 END-MITRE CUT 1 END
CB9	2	90 DEGREE JOINER
A10	2	1200MM LENGTH OF PHFC4 EXTRUSION-WITH MITRE CUT FOR CB9 ONE END-IB2 LOCK HOLE ONE END
IB2-O	1	JOINER BAR (OLD STYLE)

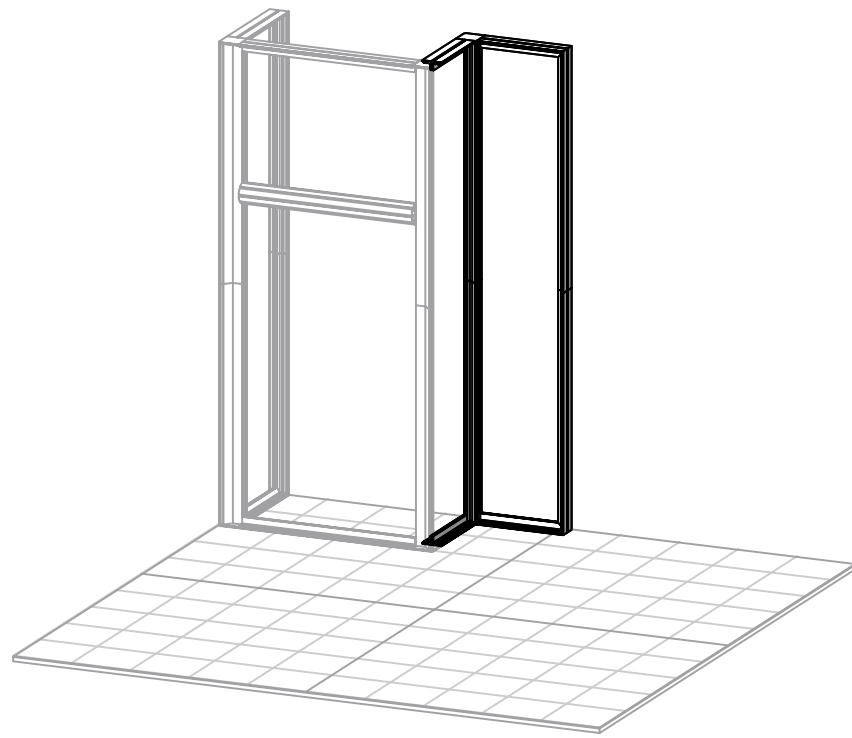
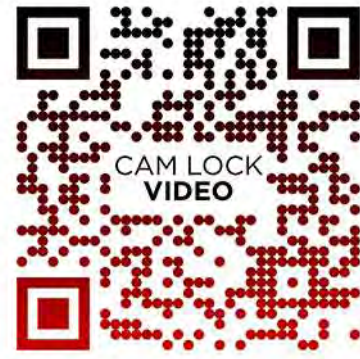

COMPONENTS
IN THIS STEP:
(Not to scale)

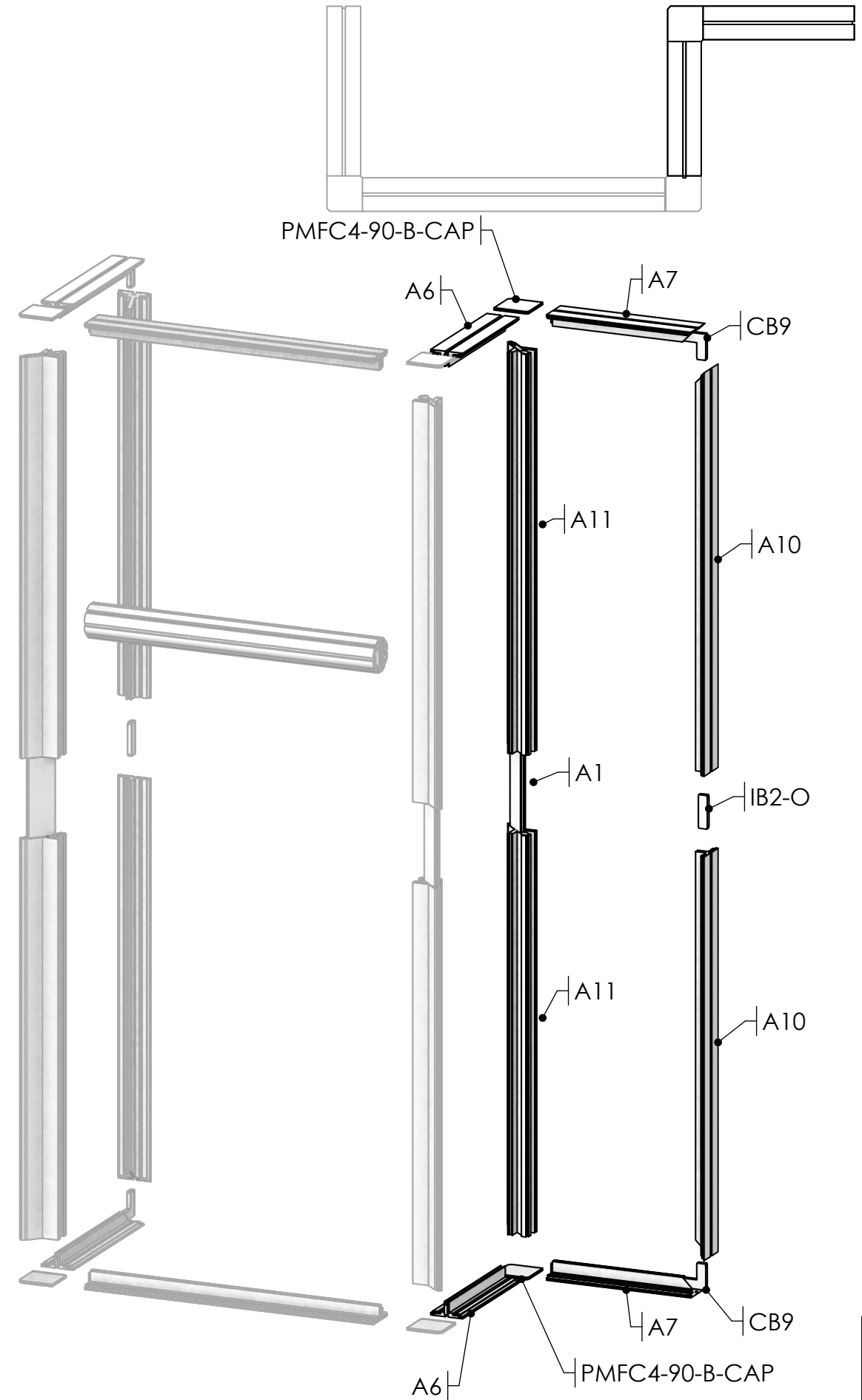
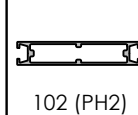
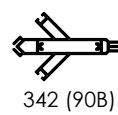

SETUP#	#	DESCRIPTION
A12	1	900MM W X 1200MM H LOCK SLOTWALL PANEL
A4	4	900MM LENGTH OF PHFC2 EXTRUSION-WITH MITRE CUT BOTH ENDS
A5	2	900MM LENGTH OF PHFC2 EXTRUSION-WITH MITRE CUT BOTH ENDS-WITH SIDE LOCKS
CB9	8	90 DEGREE JOINER
A3	2	300MM LENGTH OF PHFC2 EXTRUSION-WITH MITRE CUT BOTH ENDS-WITH SIDE LOCKS

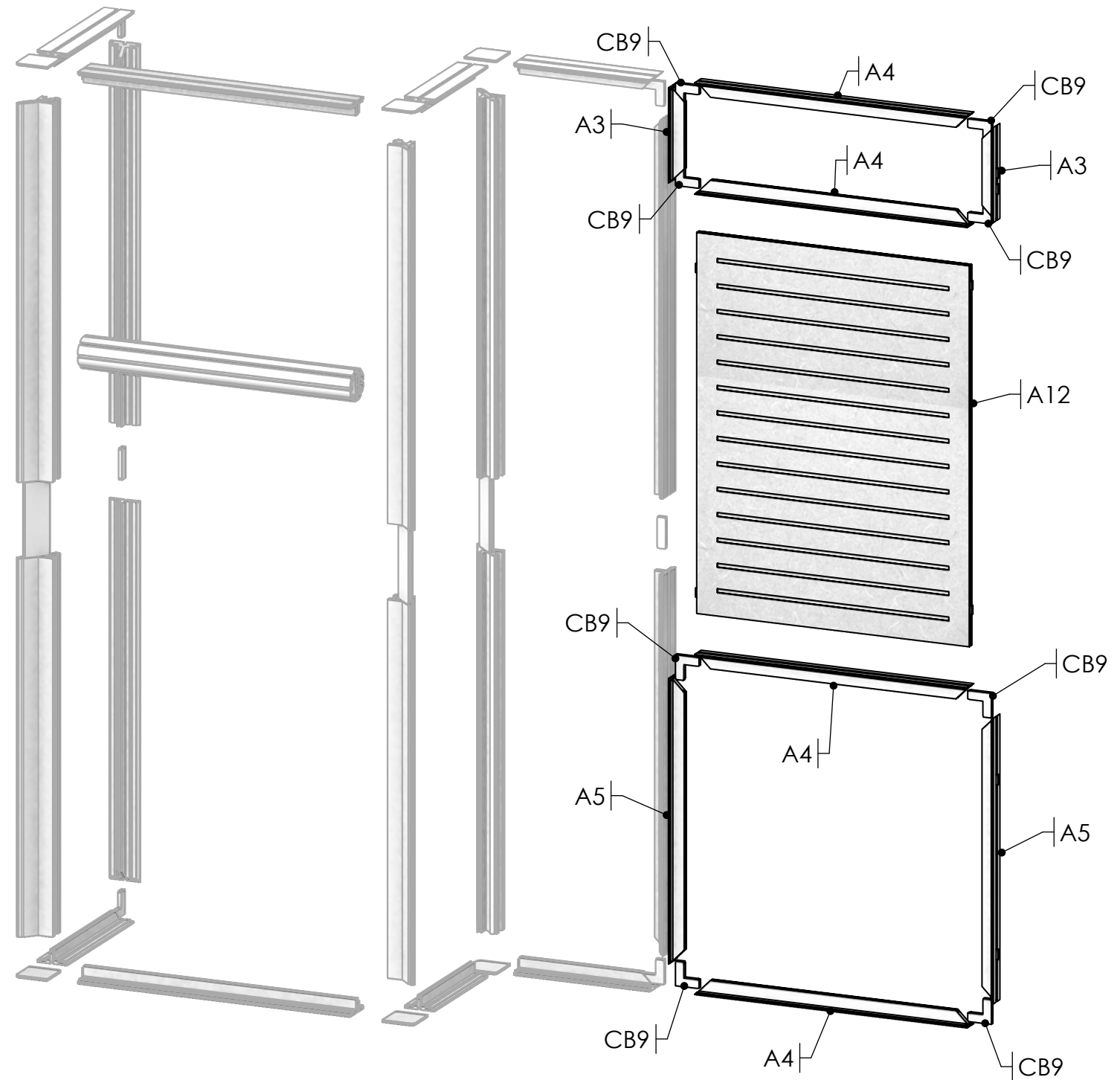
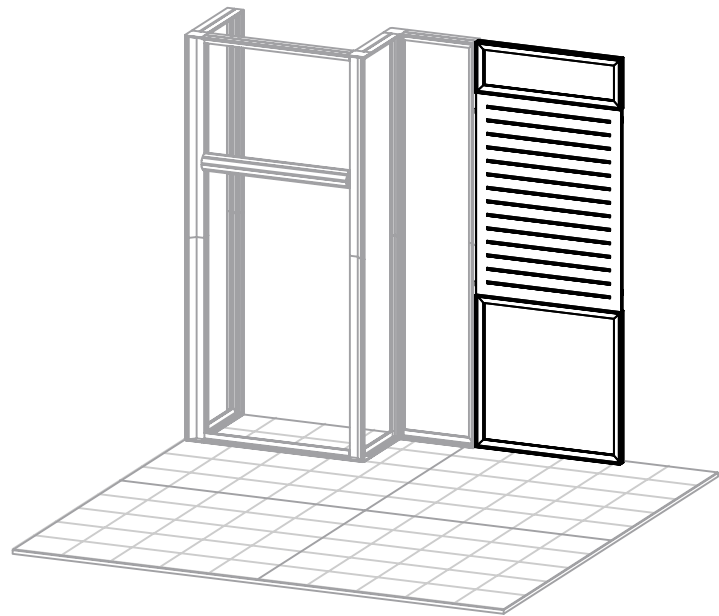
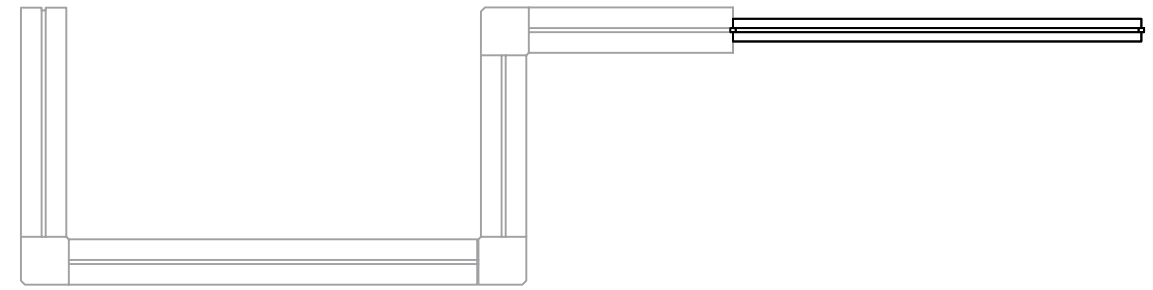

COMPONENTS
IN THIS STEP:
(Not to scale)



SETUP#	#	DESCRIPTION
PMFC4-90-B-CAP	2	PLASTIC MOLDED END CAP FOR THE PMFC4-90-B EXTRUSION
A11	2	1193MM OF PMFC4-90-B EXTRUSION -WITH STOPS AT 315MM
A1	1	600MM LENGTH OF PH2 EXTRUSION
A7	2	450MM LENGTH OF PHFC4 EXTRUSION-WITH CAM LOCK 1 END-MITRE CUT 1 END
CB9	2	90 DEGREE JOINER
A10	2	1200MM LENGTH OF PHFC4 EXTRUSION-WITH MITRE CUT FOR CB9 ONE END-IB2 LOCK HOLE ONE END
IB2-O	1	JOINER BAR (OLD STYLE)

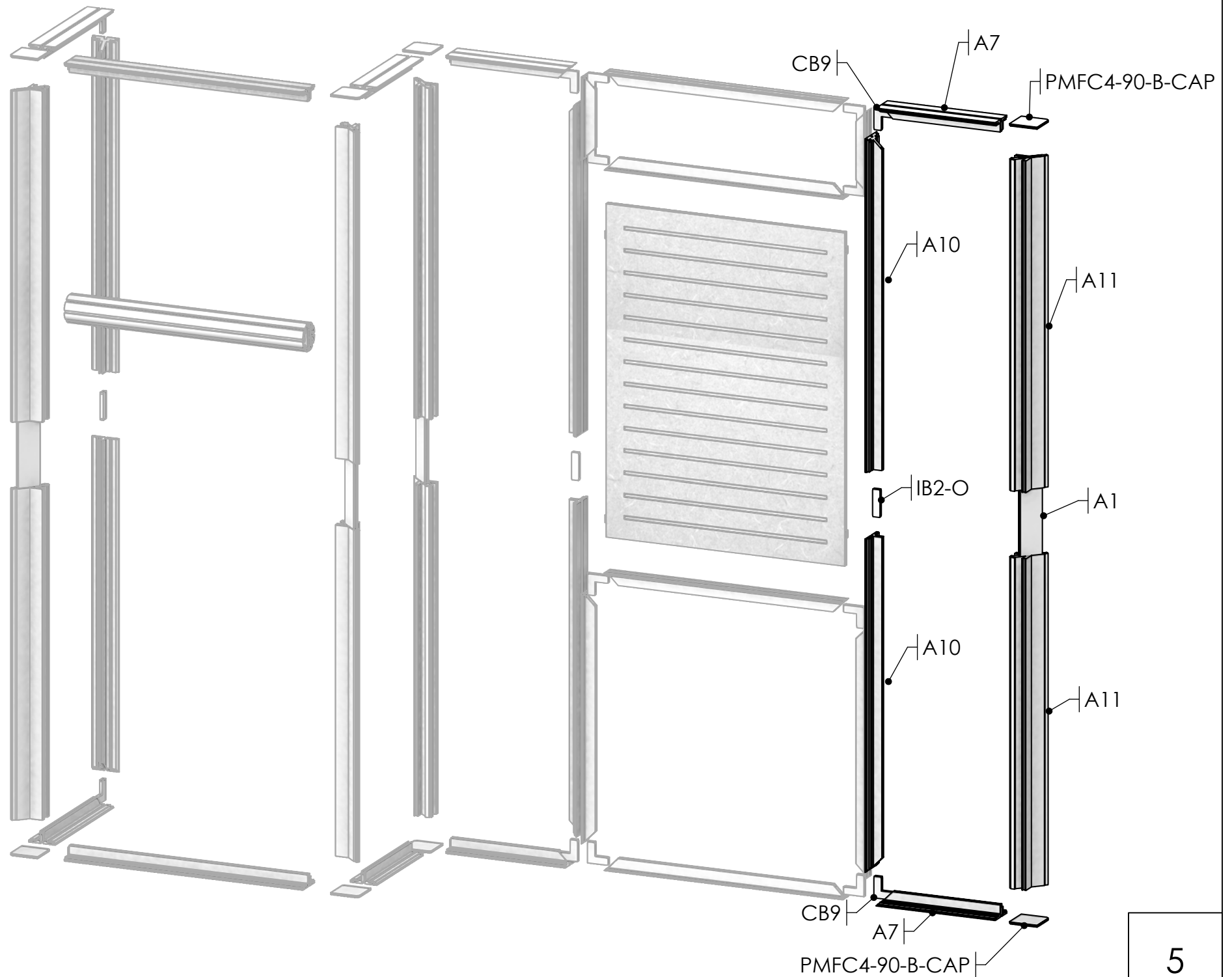
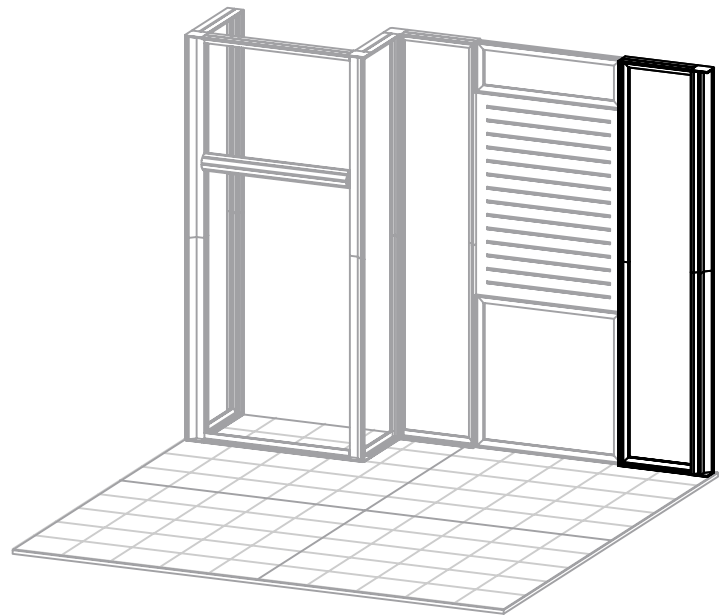

COMPONENTS IN THIS STEP: (Not to scale)			
	342 (90B)	340 (PHFC4)	102 (PH2)

SETUP#	#	DESCRIPTION
A7	2	450MM LENGTH OF PHFC4 EXTRUSION-WITH CAM LOCK 1 END-MITRE CUT 1 END
CB9	2	90 DEGREE JOINER
A10	2	1200MM LENGTH OF PHFC4 EXTRUSION-WITH MITRE CUT FOR CB9 ONE END-IB2 LOCK HOLE ONE END
IB2-O	1	JOINER BAR (OLD STYLE)

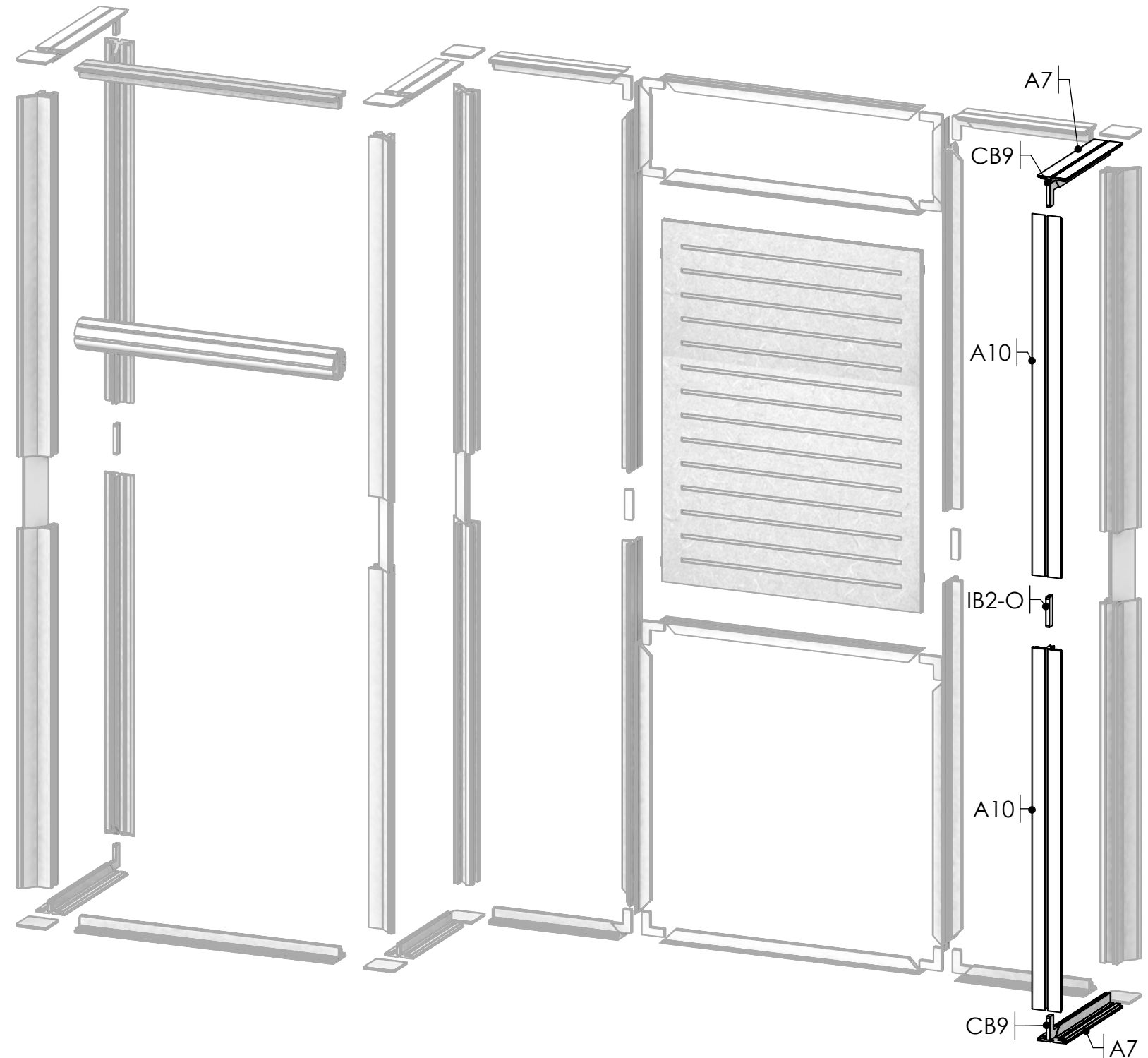
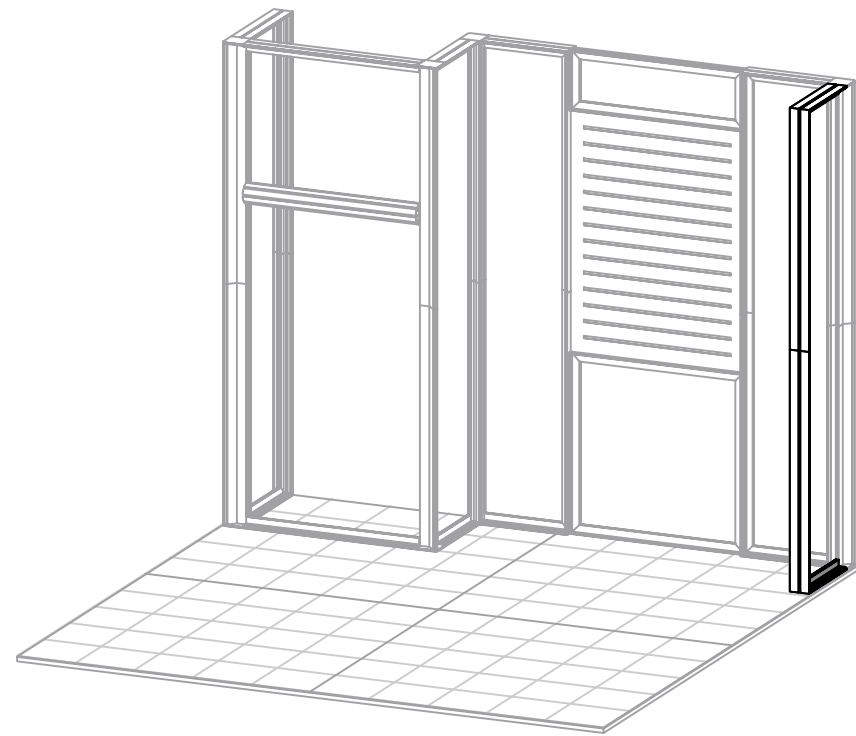
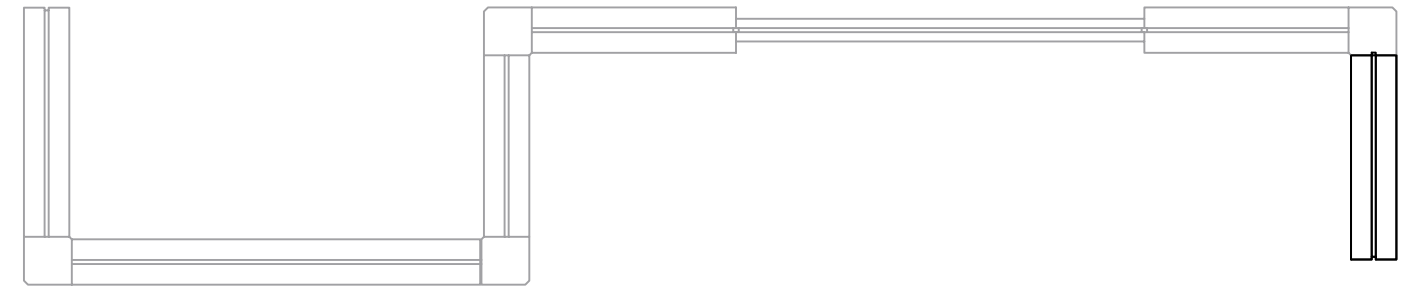

COMPONENTS
IN THIS STEP:
(Not to scale)

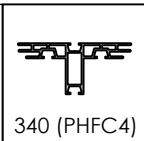

SETUP#	#	DESCRIPTION
GR-G	1	GRAPHIC (G) (21.87 w X 98.37 h total size) 17.87 w X 94.37 h finish size, Dye-sub print on Eclipse Blockout Stretch, single sided, sewn with FCE-2 silicone beading around perimeter & pull tab in bottom right corner
GR-H	1	GRAPHIC (H) (21.87 w X 98.37 h total size) 17.87 w X 94.37 h finish size, Dye-sub print on Eclipse Blockout Stretch, single sided, sewn with FCE-2 silicone beading around perimeter & pull tab in bottom right corner
GR-D	1	GRAPHIC (D) (21.87 w X 98.37 h total size) 17.87 w X 94.37 h finish size, Dye-sub print on Eclipse Blockout Stretch, single sided, sewn with FCE-2 silicone beading around perimeter & pull tab in bottom right corner
GR-C	1	GRAPHIC (C) (23.92 w X 98.37 h total size) 19.92 w X 94.37 h finish size, Dye-sub print on Eclipse Blockout Stretch, single sided, sewn with FCE-2 silicone beading around perimeter & pull tab in bottom right corner
GR-B	1	GRAPHIC (B) (47.46 w X 98.37 h total size) 43.46 w X 94.37 h finish size, Dye-sub print on Eclipse Blockout Stretch, single sided, sewn with FCE-2 silicone beading around perimeter & pull tab in bottom right corner
GR-A	1	GRAPHIC (A) (27.82 w X 98.37 h total size) 23.82 w X 94.37 h finish size, Dye-sub print on Eclipse Blockout Stretch, single sided, sewn with FCE-2 silicone beading around perimeter & pull tab in bottom right corner
GR-F	1	GRAPHIC (F) (39.31 w X 39.31 h total size) 35.31 w X 35.31 h finish size, Dye-sub print on Eclipse Blockout Stretch, single sided, sewn with FCE-2 silicone beading around perimeter & pull tab in bottom right corner
GR-E	1	GRAPHIC (E) (39.31 w X 15.69 h total size) 35.31 w X 11.69 h finish size, Dye-sub print on Eclipse Blockout Stretch, single sided, sewn with FCE-2 silicone beading around perimeter & pull tab in bottom right corner

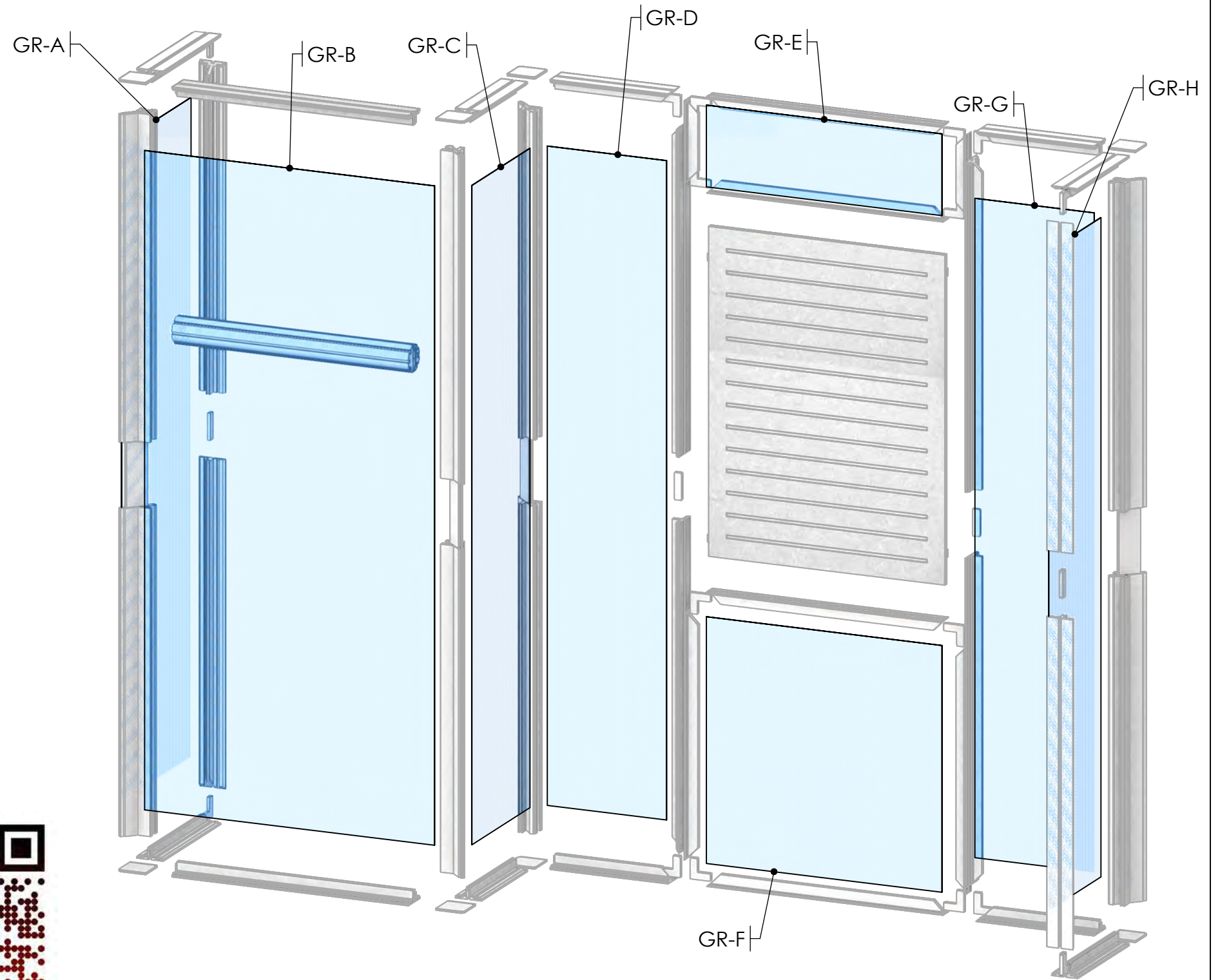
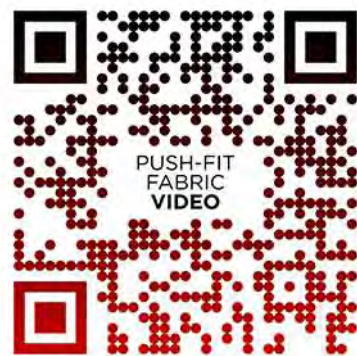

SETUP#	#	DESCRIPTION
GR-I	1	GRAPHIC (I) (25.65 w X 98.37 h total size) 21.65 w X 94.37 h finish size, Dye-sub print on Eclipse Blockout Stretch, single sided, sewn with FCE-2 silicone beading around perimeter & pull tab in bottom right corner
LUM-LED2-ORL-B	1	25 WATT BLACK LED STEM LIGHT (REPLACES 200 W HALOGEN)
EXT-LG-MB	1	Large LCD Monitor mount, 37" - 70" size, 110 Lb. max. weight, Tilting-with extrusion mounted hardware

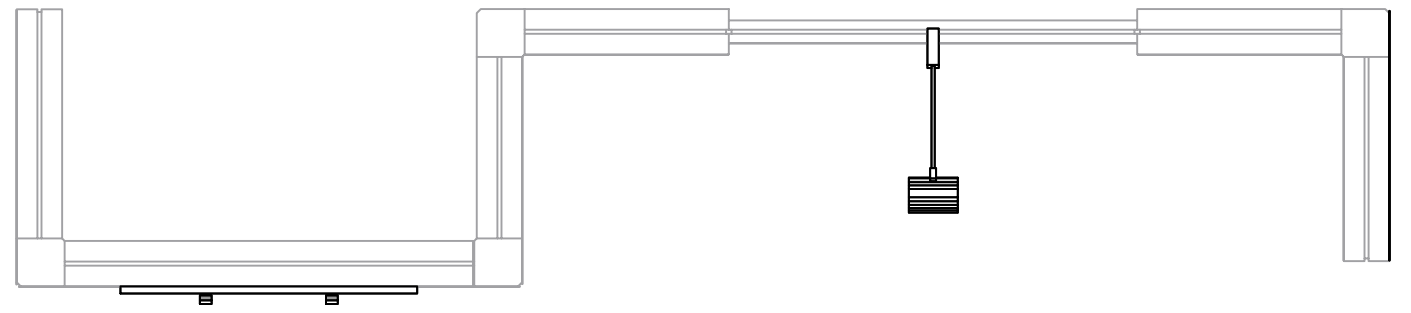

LARGE MONITOR MOUNT

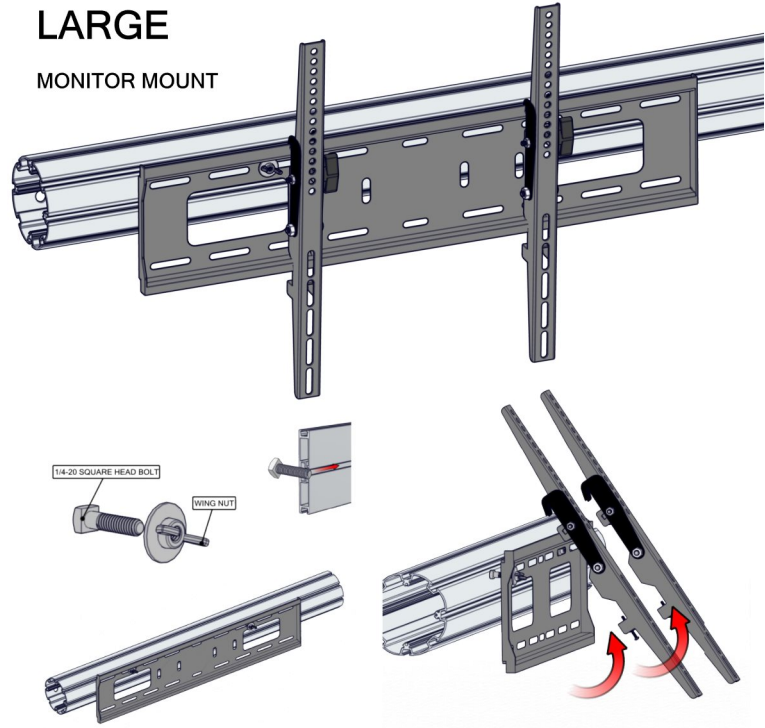

EXT-LG-MB

