

# Hybrid Pro 20FT Modular Backwall Kit 37

HP-K-37

Hybrid Pro™ Modular Kit 37 is a bright, bold and beautiful 20ft display. It features four Blaze™ Light Boxes one on each end and one on each side of the center. Three panels incorporate MODify™ merchandising walls and shelving for product display and presentation. Each section has SEG push-fit fabric graphics for branding and messaging; graphics are extremely easy to swap and replace. This versatile single-sided display can be used for exhibits and for retail stores!



We are continually improving and modifying our product range and reserve the right to vary the specifications without prior notice. All dimensions and weights quoted are approximate and we accept no responsibility for variance. E&OE. See Graphic Templates for graphic bleed specifications

## features and benefits:

- Silver aluminum extrusion frames
- 4 light boxes, one on each end & one on each side of the center panel
- 6 silver steel shelves and 3 silver base decks for merchandising
- 7 single-sided SEG dye-sublimated push-fit fabric graphics, 4 illuminated, 3 non
- Cases included: OCH2 (4)
- Lifetime hardware warranty against manufacturer defects

## dimensions:

### Hardware

Assembled unit:

233.88" w x 94.50" h x 29.72" d  
5,941 mm(w) x 2400mm(h) x 755(d)

Approximate Weight:  
434 lbs / 197 kg

### Graphics

Refer to related graphic templates for more information Visit:

<https://www.theexhibitorshandbook.com/downloads/download-graphic-templates> or click here

### Shipping

Packing case(s):  
4 OCH2

OCH2:  
(52" L x 29" H x 15" D)  
1321mm(l) x 737mm(h) x 381mm(d)

Approximate shipping weight:  
553 lbs / 250 kg



This product may include the following materials for recycle: aluminum, select wood, fabric, cardboard, paper, steel, and plastics.

## additional information:

Graphic material:

Dye-sublimation SEG push-fit fabric

2 person assembly recommended:



HP-K-37

SETUP INSTRUCTIONS

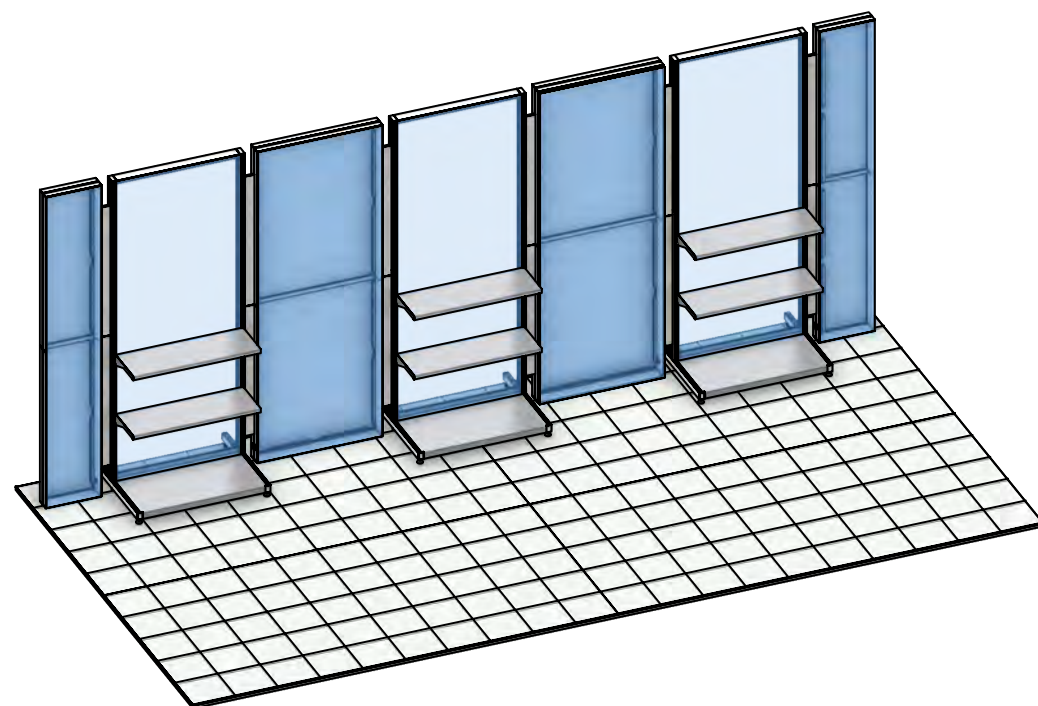
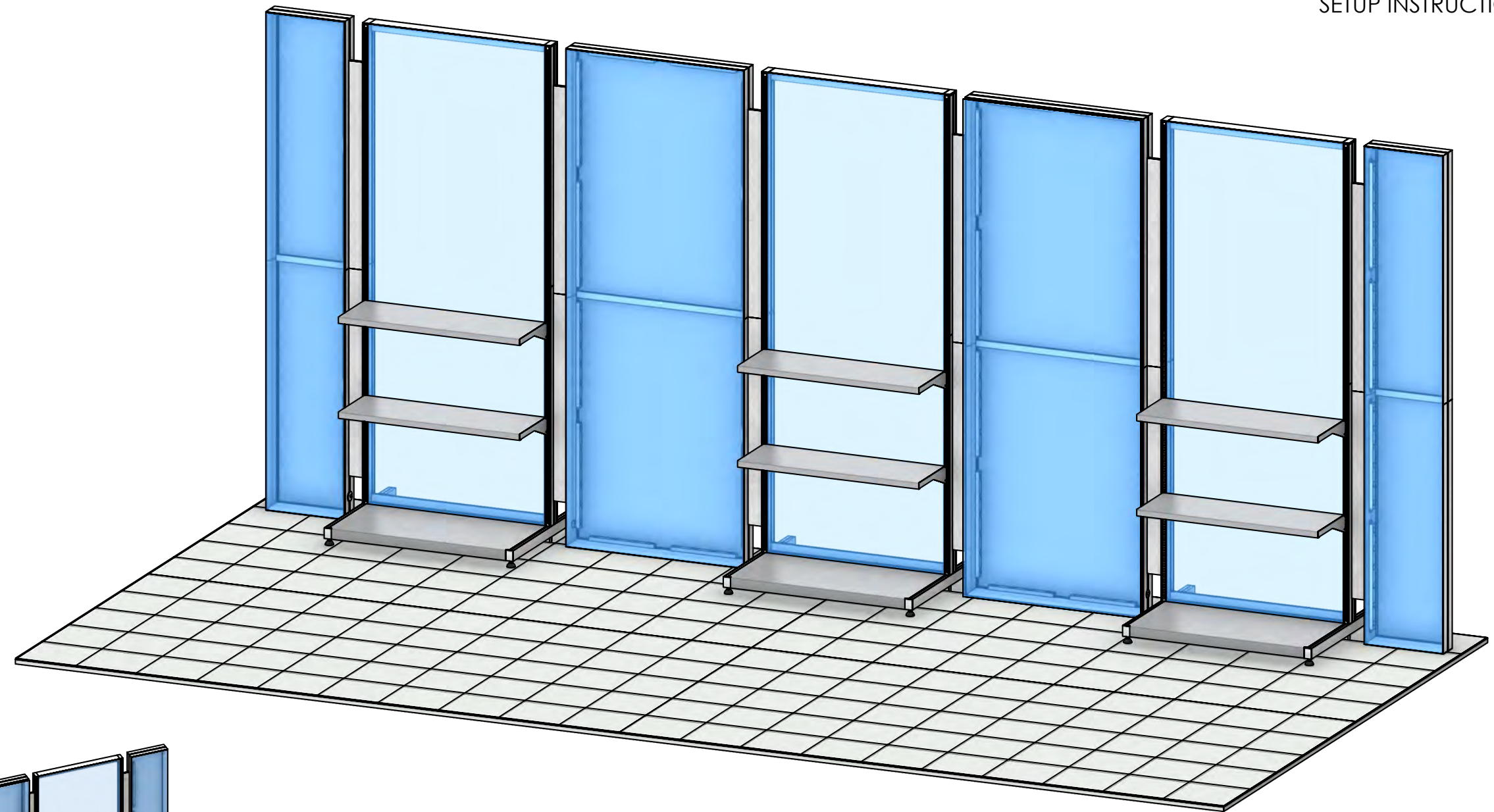

## PROJECT BOM

SETUP#	HARDWARE	#	DESCRIPTION
A1	101-354-01-01-PW	2	354MM LENGTH OF PH1 POWDERCOATED EXTRUSION-WITH CAM LOCKS BOTH ENDS
A2	101-854-01-01-PW	2	854MM LENGTH OF PH1 POWDERCOATED EXTRUSION-WITH CAM LOCKS BOTH ENDS
A3	102-1000-68	12	1000MM LENGTH OF PH2 EXTRUSION-WITH SIDE LOCKS BOTH SIDES
A4	348-400-32-32	4	400MM (15.75in) LENGTH OF 348 SILVER EXTRUSION-WITH MITRE CUT BOTH ENDS
A5	348-900-32-32	4	900MM (35.43in) LENGTH OF 348 SILVER EXTRUSION-WITH MITRE CUT BOTH ENDS
A6	348-1200-02-26-32	6	1200MM (47.24in) LENGTH OF 348 SILVER EXTRUSION-WITH MITRE CUT RIGHT END FOR CB10-IB2 LOCK HOLE LEFT END
A12	348-1200-02-32-26	6	1200MM (47.24in) LENGTH OF 348 SILVER EXTRUSION-WITH MITRE CUT LEFT END FOR CB10-IB2 LOCK HOLE RIGHT END
A11	348-1200-02-69	2	1200MM (47.24in) LENGTH OF 348 SILVER EXTRUSION-WITH MITRE CUT LEFT END FOR CB10-IB2 LOCK HOLE RIGHT END-WITH GROMMET HOLE 100MM FROM LEFT END.
A7	348-1200-02-69	2	1200MM (47.24in) LENGTH OF 348 SILVER EXTRUSION-WITH MITRE CUT LEFT END FOR CB10-IB2 LOCK HOLE RIGHT END-WITH GROMMET HOLE 100MM FROM LEFT END.
A8	824-750-49-49-50	6	750MM (29.53in) LENGTH OF 824 CORNER POST EXTRUSION -WITH THRU HOLE FOR 3/8 BOLT, 38.1MM FROM END, 2 MFY LEVEL FEET, 824-EC CAP
A9	830-1155-52-52-53	6	1155MM (45.47in) OF 830 SINGLE SIDED UPRIGHT OPEN EXTRUSION WITH MFY-EPIN & 39.59 SHELF STD
A13	830-1155-52-52-53	6	1155MM (45.47in) OF 830 SINGLE SIDED UPRIGHT OPEN EXTRUSION WITH MFY-39.59 SHELF STD
831-833-EC	831-833-EC	6	7MM SEG PLASTIC END CAP FOR 831-833 EXTRUSION
A10	835-883-01-01	6	883MM (34.76in) OF 835 DOUBLE SIDED SEG EXTRUSION -WITH CAM LOCKS BOTH ENDS
CB10	CB10	16	CB10 90 DEGREE CONNECTOR
IB2-O	IB2-O	8	JOINER BAR (OLD STYLE)
LED-EV-CORD-8	LED-EV-CORD-8	2	POWER CORD FOR AC LIGHTBAR - 8FT
LED-EV-THUMB-ORB	LED-EV-THUMB-ORB	64	THUMB KNOB, ORBUS VERSION, FOR LED LIGHT BAR
LED-EV-WHT-6000-10	LED-EV-WHT-6000-10	8	LIGHT BAR (SEG), AC POWER, 6000K, 14" L
LED-EV-WHT-6000-19	LED-EV-WHT-6000-19	24	LIGHT BAR (SEG), AC POWER, 6000K, 21" L
MFY-DB-36-17	MFY-DB-36-17	3	36"W X 17"D DROP IN BASE WITH 2" TOE KICK
MFY-EPIN	MFY-EPIN	6	MODify Tapered Extension Pin, 5/16-18 thread
MFY-SLF-36-12	MFY-SLF-36-12	6	36"W X 12"D SHELF
SETUP#	GRAPHICS	#	DESCRIPTION
A	HP-37-A-G	1	GRAPHIC (A) (19.63 w X 98.37 h total size ) 15.63 w X 94.37 h finish size, Dye-sub print on Backlit Textile, single sided, sewn with silicone beading around perimeter & pull tab in bottom right corner
B	HP-37-B-G	1	LINER (B) (19.63 w X 98.37 h total size ) 15.63 w X 94.37 h finish size, Opaque Liner, sewn with FCE-2 silicone beading around perimeter & pull tab in bottom right corner
C	HP-37-C-G	1	GRAPHIC (C) (39.26 w X 95.04 h total size ) 35.26 w X 91.04 h finish size, Dye-sub print on Eclipse Blockout Stretch, single sided, sewn with FCE-2 silicone beading around perimeter & pull tab in bottom right corner (WITH 1/4" NOTCH LEFT & RIGHT BOTTOM HORIZONTAL SIDE CORNERS)
D	HP-37-D-G	1	GRAPHIC (D) (39.31 w X 98.37 h total size ) 35.31 w X 94.37 h finish size, Dye-sub print on Backlit Textile, single sided, sewn with silicone beading around perimeter & pull tab in bottom right corner
E	HP-37-E-G	1	LINER (E) (39.31 w X 98.37 h total size ) 35.31 w X 94.37 h finish size, Opaque Liner, sewn with FCE-2 silicone beading around perimeter & pull tab in bottom right corner
F	HP-37-F-G	1	GRAPHIC (F) (39.26 w X 95.04 h total size ) 35.26 w X 91.04 h finish size, Dye-sub print on Eclipse Blockout Stretch, single sided, sewn with FCE-2 silicone beading around perimeter & pull tab in bottom right corner (WITH 1/4" NOTCH LEFT & RIGHT BOTTOM HORIZONTAL SIDE CORNERS)
G	HP-37-G-G	1	GRAPHIC (G) (39.31 w X 98.37 h total size ) 35.31 w X 94.37 h finish size, Dye-sub print on Backlit Textile, single sided, sewn with silicone beading around perimeter & pull tab in bottom right corner
H	HP-37-H-G	1	LINER (H) (39.31 w X 98.37 h total size ) 35.31 w X 94.37 h finish size, Opaque Liner, sewn with FCE-2 silicone beading around perimeter & pull tab in bottom right corner
I	HP-37-I-G	1	GRAPHIC (I) (39.26 w X 95.04 h total size ) 35.26 w X 91.04 h finish size, Dye-sub print on Eclipse Blockout Stretch, single sided, sewn with FCE-2 silicone beading around perimeter & pull tab in bottom right corner (WITH 1/4" NOTCH LEFT & RIGHT BOTTOM HORIZONTAL SIDE CORNERS)
J	HP-37-J-G	1	GRAPHIC (J) (19.63 w X 98.37 h total size ) 15.63 w X 94.37 h finish size, Dye-sub print on Backlit Textile, single sided, sewn with silicone beading around perimeter & pull tab in bottom right corner
K	HP-37-K-G	1	LINER (K) (19.63 w X 98.37 h total size ) 15.63 w X 94.37 h finish size, Opaque Liner, sewn with FCE-2 silicone beading around perimeter & pull tab in bottom right corner



# FABRIC, VINYL & UV GRAPHIC CARE GUIDELINES

## GENERAL HANDLING FABRIC GRAPHICS

- Your fabric graphics should always be handled in a clean and dry area with clean hands. When possible, use white fabric gloves.
- Be sure fabric is clean and dry before packing.
- Machine washing and/or drying is not recommended for all fabrics. Refer to the chart below for which fabrics are washable.

## EMERGENCY STAIN TREATMENT (FABRIC)

- For dry stains, like loose dirt or pencil marks, try initially using masking tape or Magic Eraser (dry-not moistened).
- Introduce water or liquids to treat stains, if at all possible, treat the stain with fabric off of the frame.

- Place a clean dry cloth behind stain (to absorb stains while being treated). Moisten another cloth initially with just water (distilled water is optimal, if available).
- Gently blot stain with moistened cloth (or small area of moistened Magic Eraser), while trying to push stain through to the back, using the dry cloth to absorb.
- Repeat using care to keep the wet area as small as possible.
- Grandma's Secret Spot remover can be an effective stain remover. Mix several drops in a small cup with clean water. Repeat above and using dry cloth on back of stain to absorb.

## MACHINE WASHING FABRIC GRAPHICS

- Cold water/delicate cycle/tumble dry low or air dry. For stretch fabrics do not use dryer, let hang dry.
- Use caution on dryer time with graphics containing liners. It's best to put tension fabric on frame when fabric is still damp and let it air dry. Always be sure that the aluminum frame is clean when mounting the damp graphic.
- Fabric stretch graphics that are washed and machine dried may shrink up to 3/4" per every 50" of fabric in the direction of the stretch and shrink up to 1/4" in non stretch direction.

## STORING & PACKING BACKLIT GRAPHICS

- To avoid cracks in the ink or having to steam graphics, Backlit fabrics should be loosely folded with bubble wrap or stored around a tube.
- Avoid folding the graphic tightly to store in a small bag or box.

## GENERAL HANDLING VINYL & UV GRAPHICS

- Vinyl banners and rigid graphics should always be handled in a clean and dry area with clean hands. When possible, use white fabric gloves.
- Be sure vinyl/ UV is clean and dry before packing. Always follow material handling and packing instructions included.
- All vinyl material should be rolled with graphic facing in to protect the graphic printed side. Roll on a tube if available.
- Avoid folding material to reduce the risk of crease lines and chipped inks. If a graphic must be folded, try and fold loosely and as few times as possible.

## EMERGENCY STAIN TREATMENT (UV)

- For dry stains, like loose dirt, pencil marks or adhesive, try initially using masking tape, Masking tape can be quite effective at lifting dry surface dirt. Try 'pulling' as much of stain away as you can and avoid rubbing the stain into the material.
- While using Windex® avoid scrubbing harshly. Too much pressure can fade the graphic print.

## GENERAL HANDLING OF ROLLABLE PVC PANELS

All mural panels, truss panels and detachables should be rolled with the graphic facing out to protect the graphic printed side. Mural panels should be stored in the original plastic sleeves that are provided with the panels.

## STEAMING FABRIC GRAPHICS

- For optimal results, steam wrinkles when fabric is tensioned and installed securely on the frame.
- Fill steamer with clean drinking water or distilled water. Avoid using water containing hard minerals.
- Hold steamer upright and hold close to fabric. Avoid touching fabric with steamer.
- Do not tap steamer as water drips may cause water marks to form on graphic

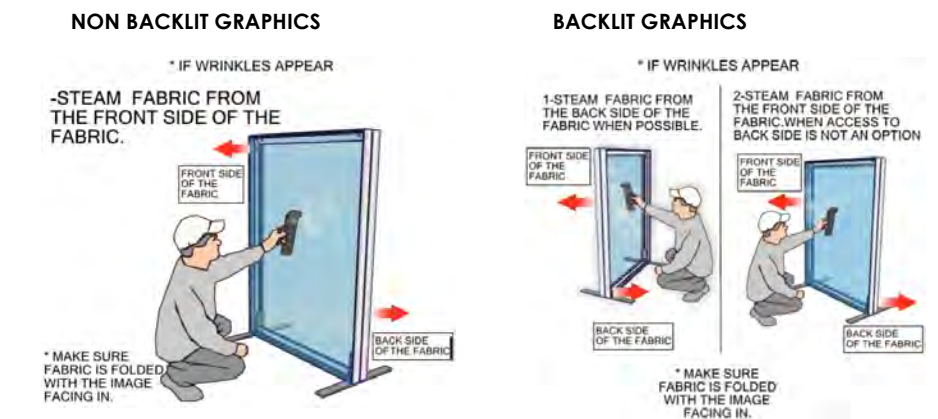

FABRIC	WASHING MACHINE	DRY CLEAN	SPOT CLEAN	STEAMING / IRON	MAGIC ERASER
RESILIENCE	NO	NO	NO	NO	YES (ONLY ON WHITE)
OXFORD	YES	YES	YES	YES	YES
POWER STRETCH	YES	YES	YES	YES	YES
DISPLAY POLYESTER	YES	YES	YES	YES	YES
DISPLY POLY TABLE THROWS	YES	YES	YES	YES	YES
OUTDOOR FLAG	YES (MUST VELCRO THE TABS)	N/A (MUST VELCRO THE TABS)	YES	YES	YES
CANVAS OUTDOOR	NO	NO	YES	STEAM ONLY	YES
CANVAS LIGHTBOX	NO	NO	NO	STEAM ONLY	YES
AGILITY	YES	YES	YES	(ONLY W/ 100% TENSION)	YES
SUPER STRETCH	YES	YES	YES	(ONLY W/ 100% TENSION)	YES
TRIPLE WHITE	YES	YES	NO	YES	NO
ECLIPSE	NO	NO	YES	STEAM ONLY	YES
SOFT KNIT	YES	YES	YES	YES	YES
SHEER	YES	YES	YES	YES	YES
VINYL & ROLLABLE					
	SOLVENT	SOAPY WATER (Dawn)	WINDEX		
FLATMAXX	ONLY ON WHITE	YES	NO		
SCRIM 13OZ/ 18OZ	ONLY ON WHITE	YES	NO		
VINLY 20OZ	ONLY ON WHITE	YES	NO		
MELINEX	NO	YES	NO		
MURAL PANELS	NO	YES	YES		
UV RIDGED	NO	YES	YES		



# SETUP NOTES

Redesign of this exhibit without approval by Orbus may result in dangerous and unsafe structures. Nimlok disclaims any responsibility for redesigned exhibits it does not approve in writing.





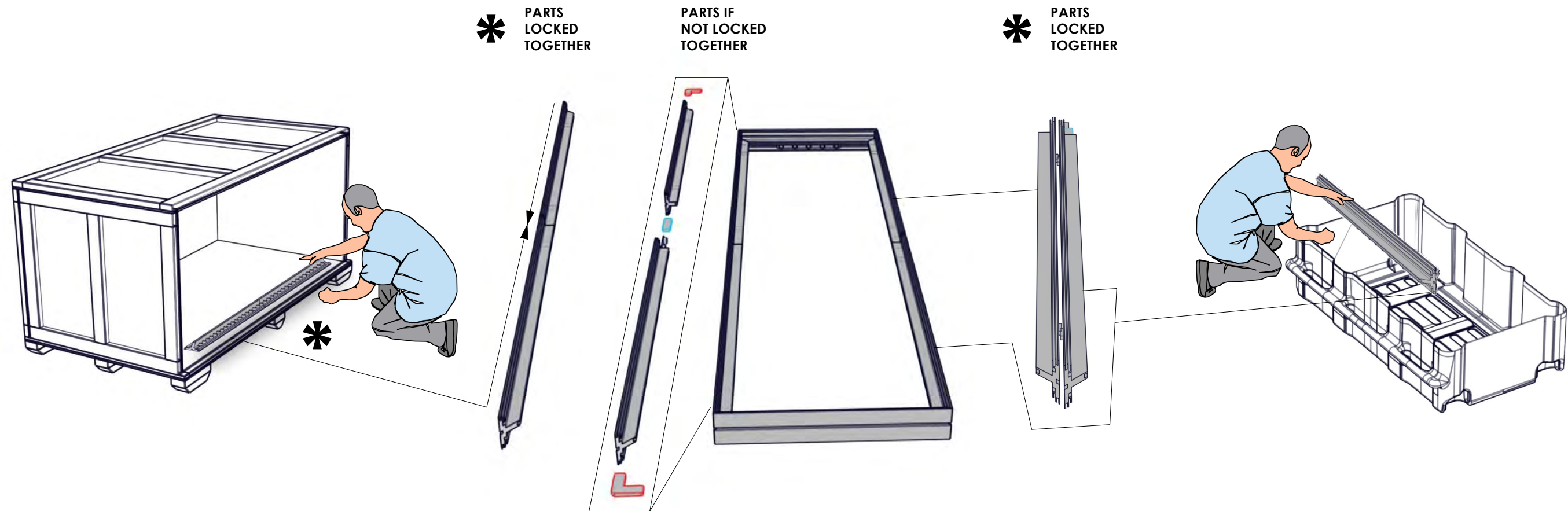

Parts and components such as panels and extrusions are manufactured to metric sizing. Where ever possible sizes have been noted in feet and inches as well as in metric. Below is the imperial to metric sizing table for reference. "Nominal" refers to approximate size.

## NOTE: PARTS MAY COME PRE-ASSEMBLED FOR PACKING PURPOSES.



### METRIC TO IMPERIAL DIMENSION

2400mm = ( 94.50" )	1200mm = ( 47.25" )
2100mm = ( 82.67" )	900mm = ( 35.43" )
1800mm = ( 70.87" )	600mm = ( 23.62" )
1500mm = ( 59.05" )	300mm = ( 11.81" )

-  Internet Connection
  Phone Line
-  Main Electric Drop (Point Of Distribution)
-  Electrical Outlet
  Sharp Edges
-  Cables Under Carpet

## HELPFUL SETUP QR CODES



**SCAN QR CODES  
WITH YOUR PHONE  
CAMERA**

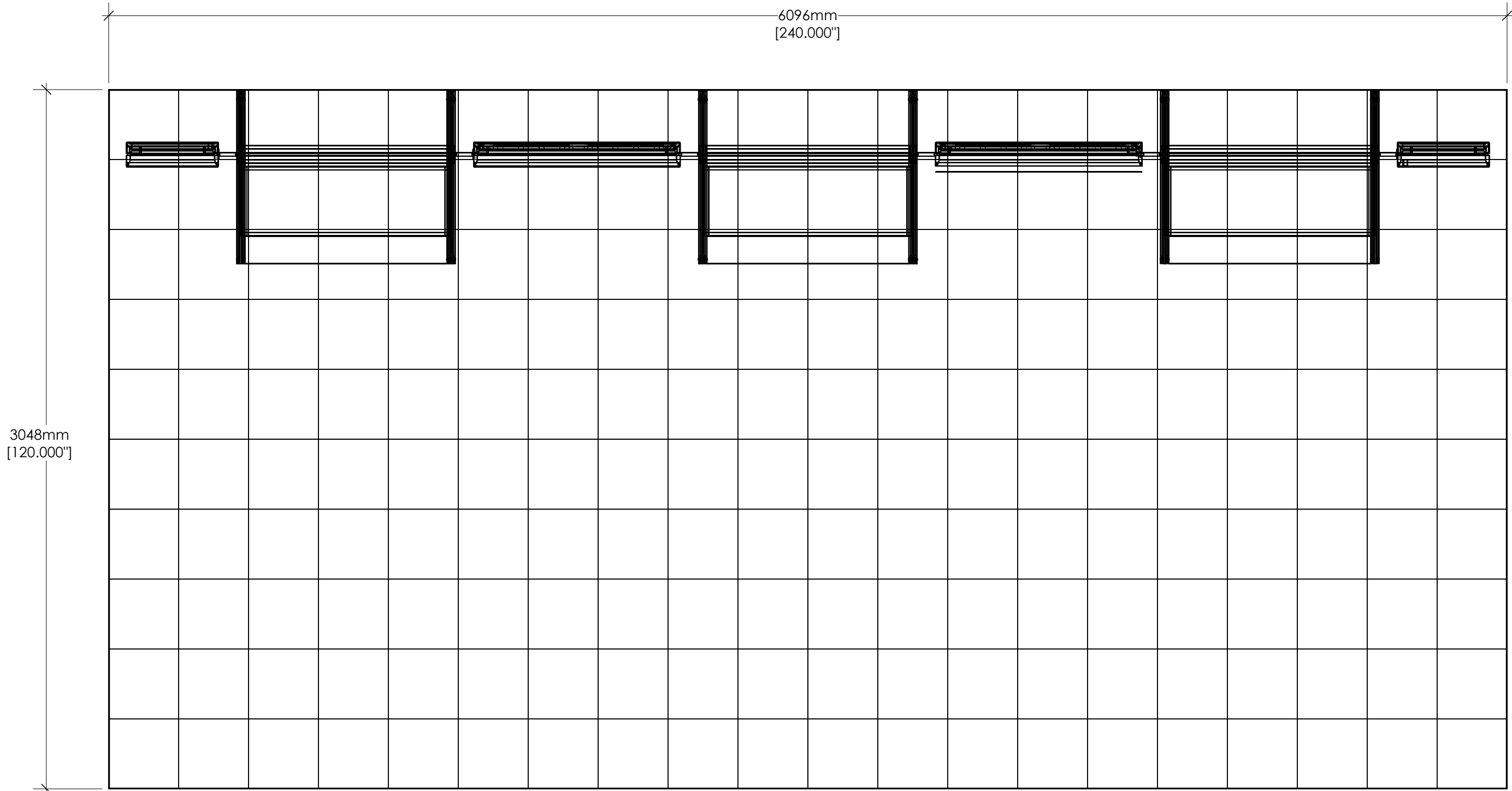



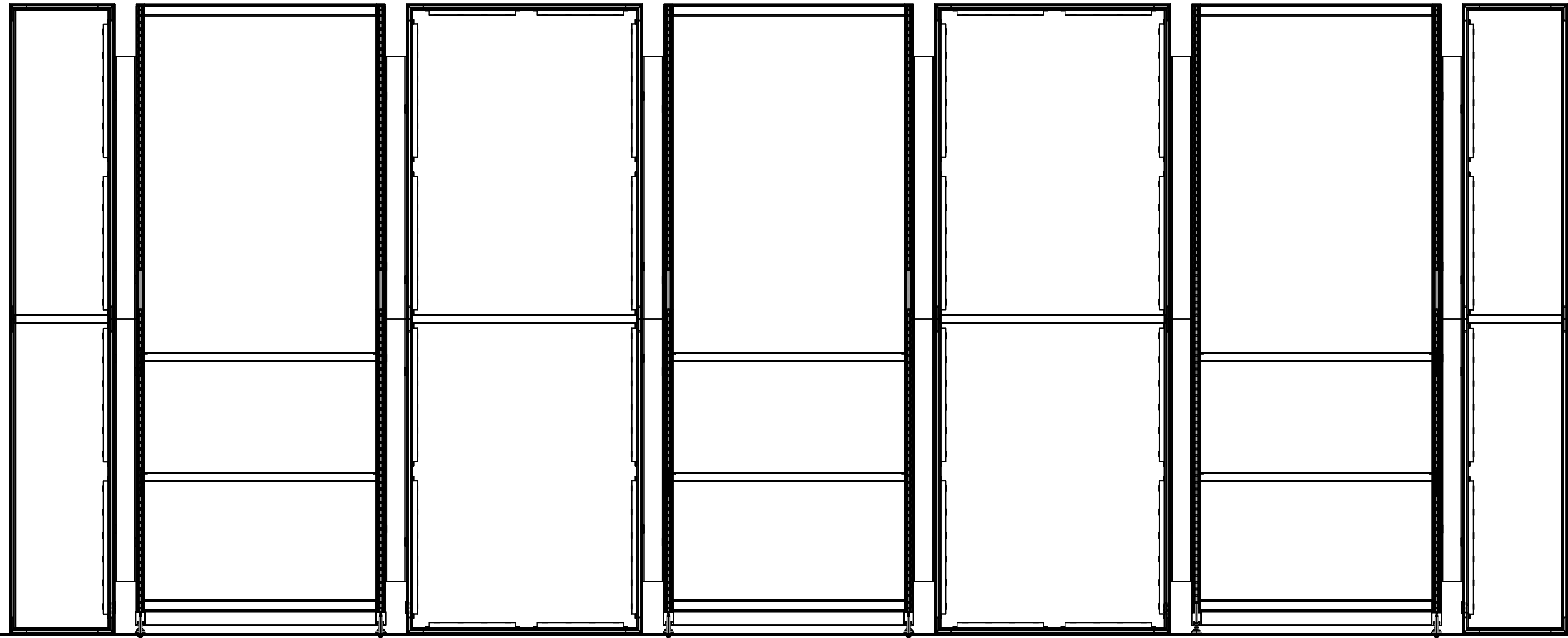

2400mm  
[94.473"]

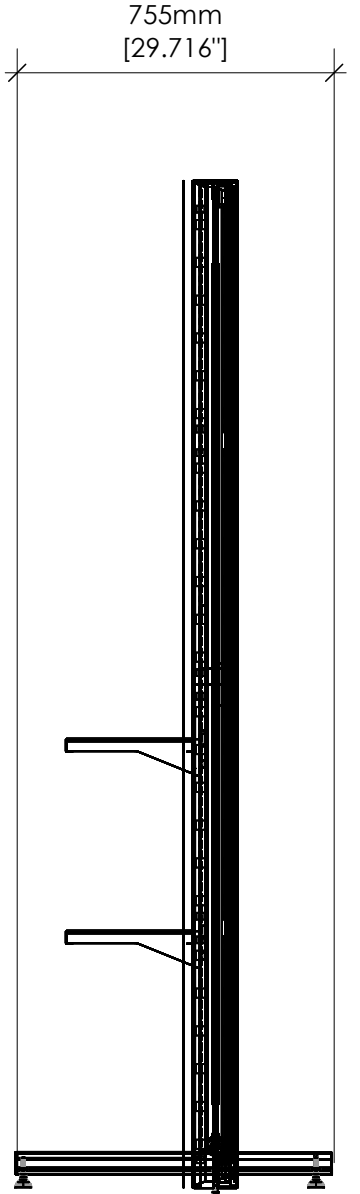

755mm  
[29.716"]

FP

SETUP#	#	DESCRIPTION
A8	6	750MM (29.53IN) LENGTH OF 824 CORNER POST EXTRUSION -WITH THRU HOLE FOR 3/8 BOLT, 38.1MM FROM END, 2 MFY LEVEL FEET, 824-EC CAP
A9	6	1155MM (45.47in) OF 830 SINGLE SIDED UPRIGHT OPEN EXTRUSION WITH MFY-EPIN & 39.59 SHELF STD
A13	6	1155MM (45.47in) OF 830 SINGLE SIDED UPRIGHT OPEN EXTRUSION WITH MFY-39.59 SHELF STD



# BUILD 6 POSTS

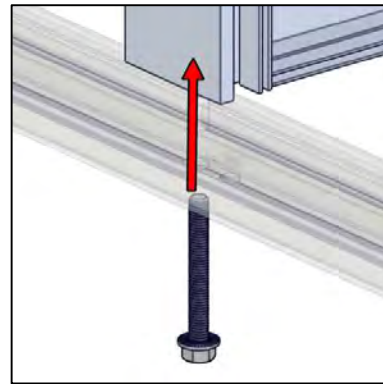
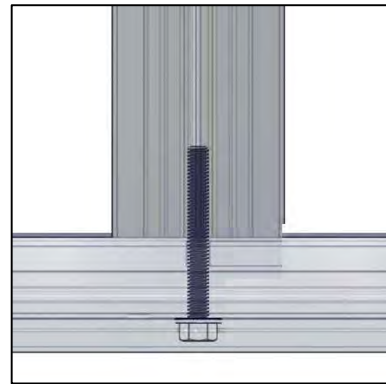

MFY-BOLT-3/8-16-2.5

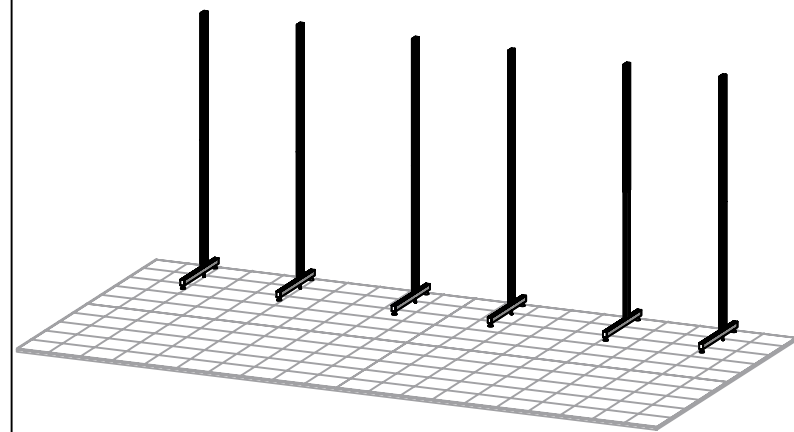
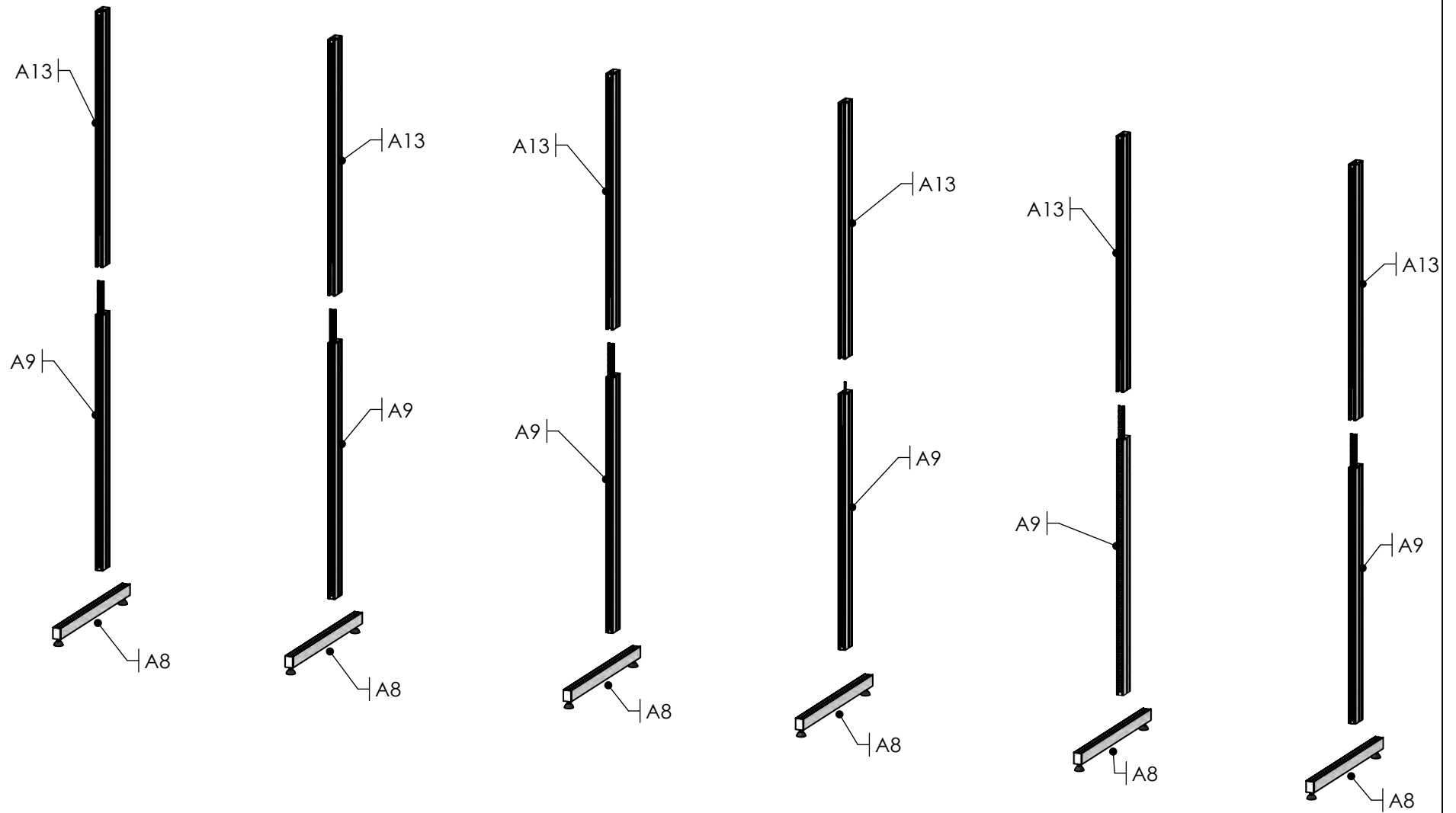

COMPONENTS  
IN THIS STEP:  
(Not to scale)

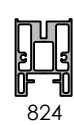

SETUP#	#	DESCRIPTION
A10	6	883MM (34.76in) OF 835 DOUBLE SIDED SEG EXTRUSION -WITH CAM LOCKS BOTH ENDS
831-833-EC	6	7MM SEG PLASTIC END CAP FOR 831-833 EXTRUSION

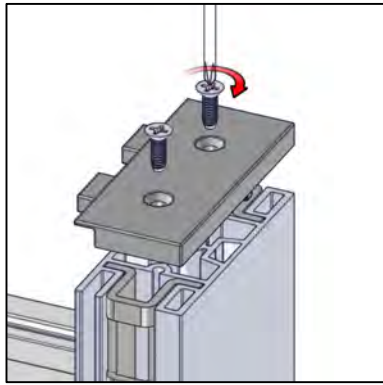

LOOSEN END CAP TO ATTACH TOP CROSS BRACE

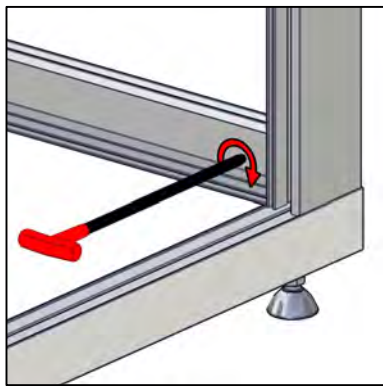

CROSS BRACE SITS ON SUPPORT LEGS

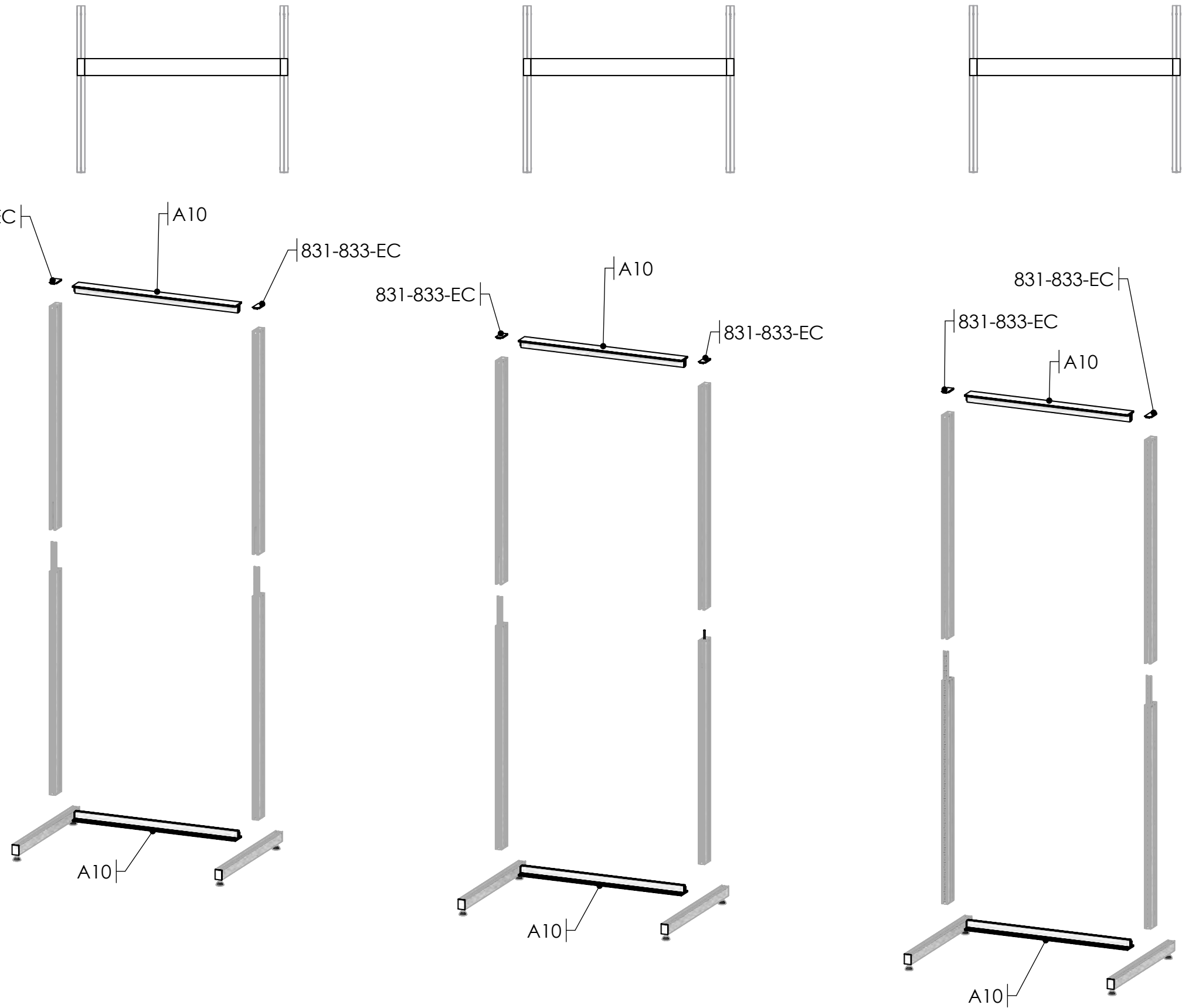
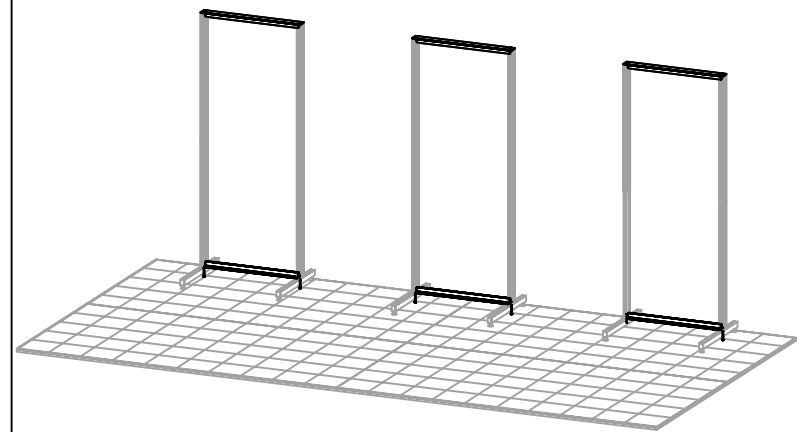

COMPONENTS  
IN THIS STEP:  
(Not to scale)

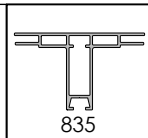



SETUP#	#	DESCRIPTION
A3	12	1000MM LENGTH OF PH2 EXTRUSION-WITH SIDE LOCKS BOTH SIDES

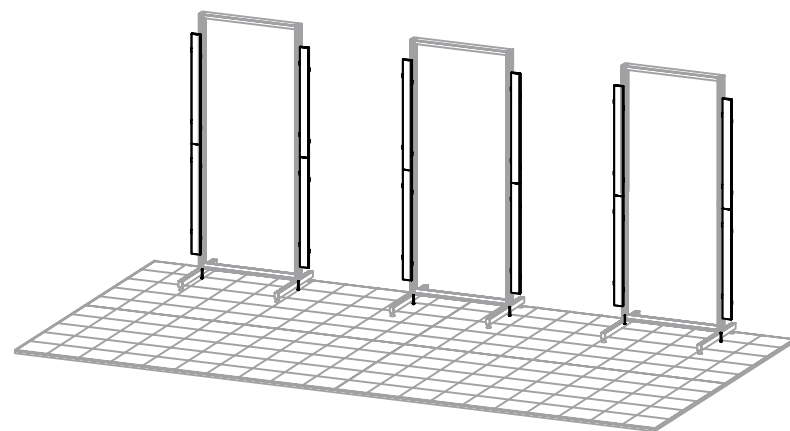
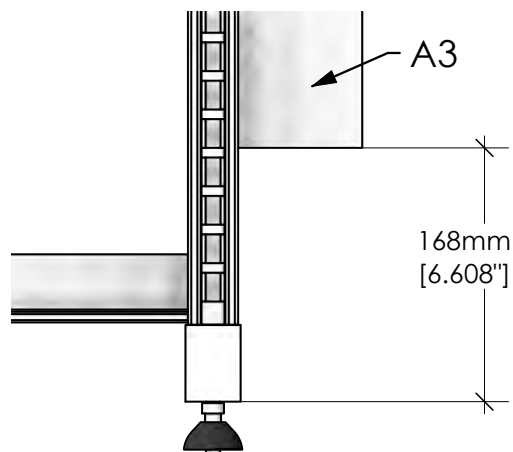

BUILD X3 UNITS

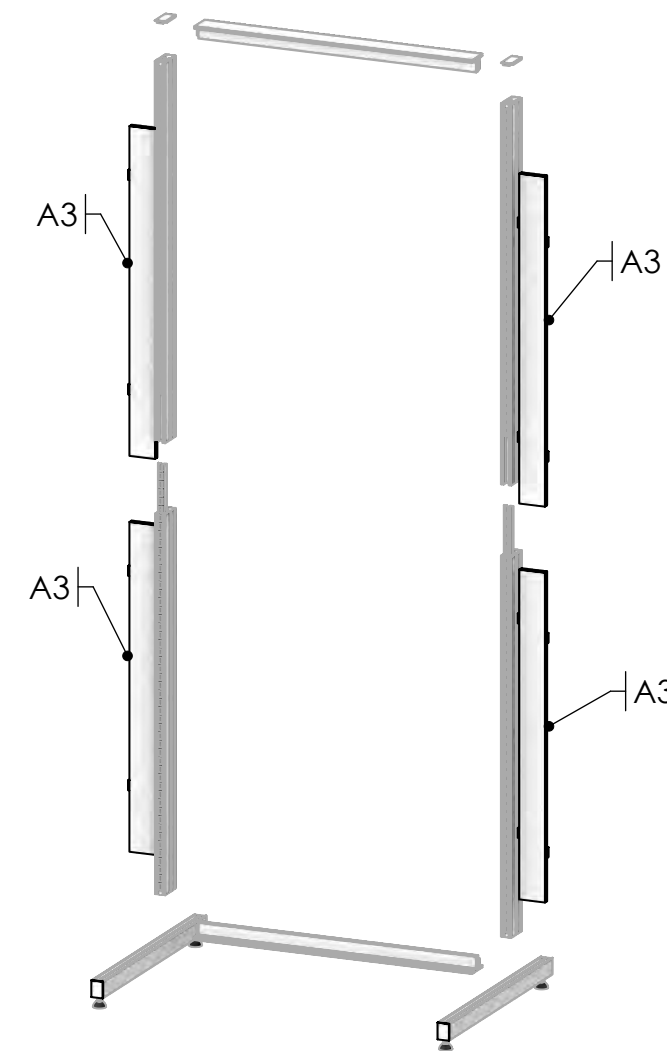
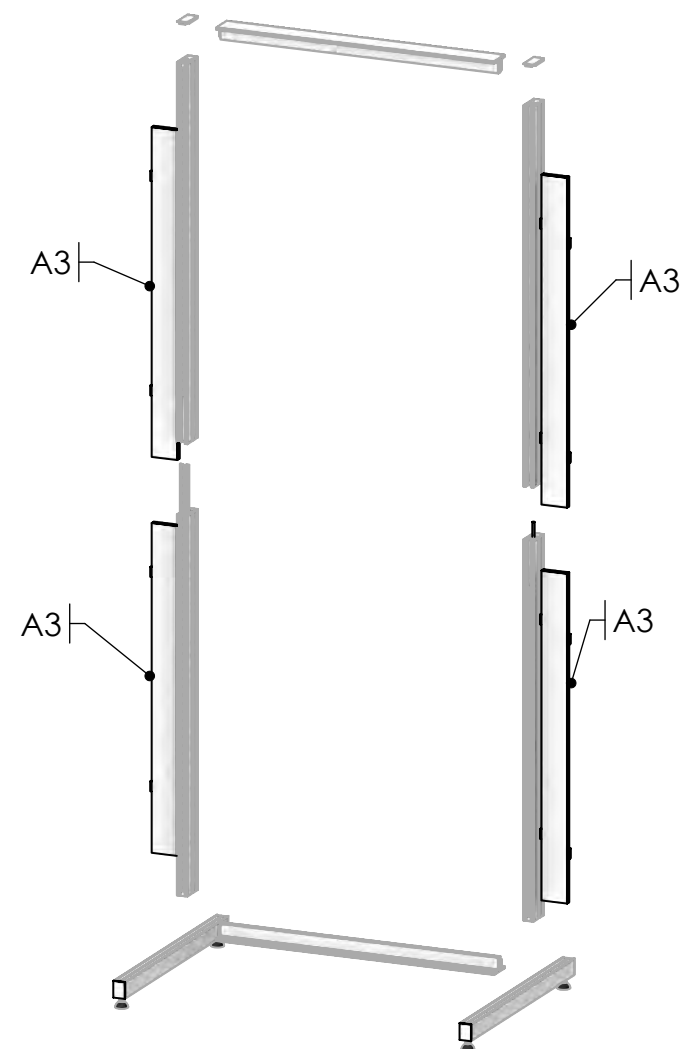
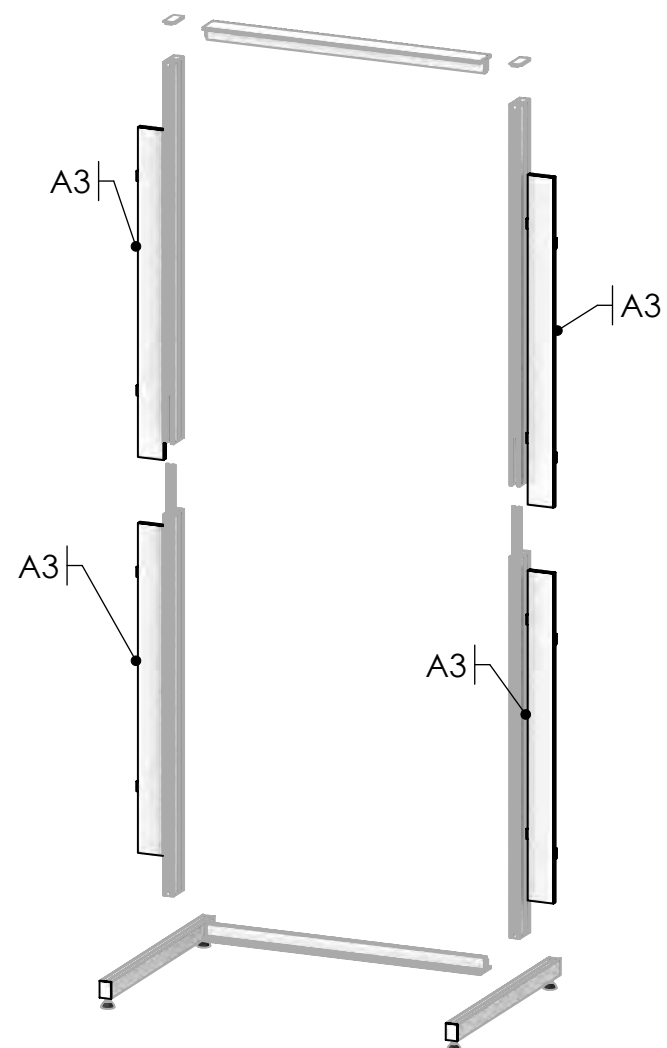

COMPONENTS  
IN THIS STEP:  
(Not to scale)



102 (PH2)

## LED Lights

Installing the LED light fixtures.

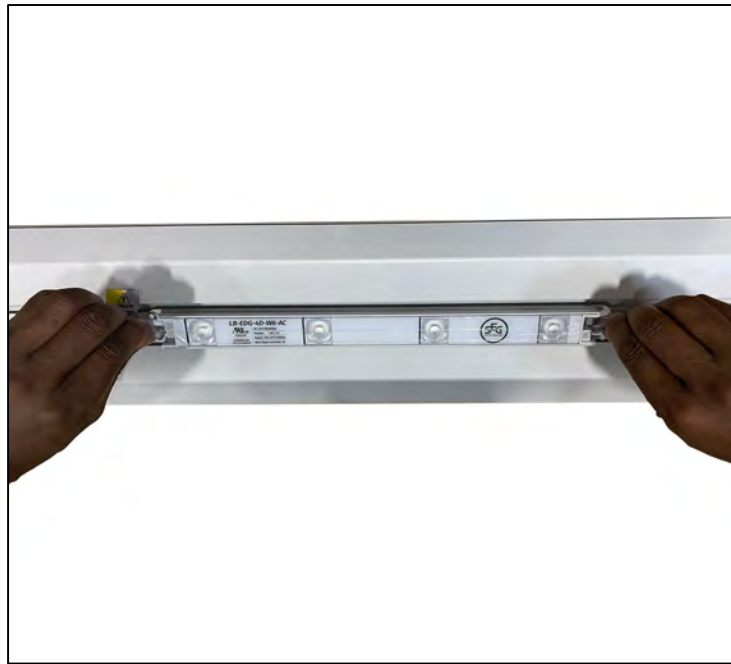

### STEP-1

Secure the LED lights with twist clips on both ends.

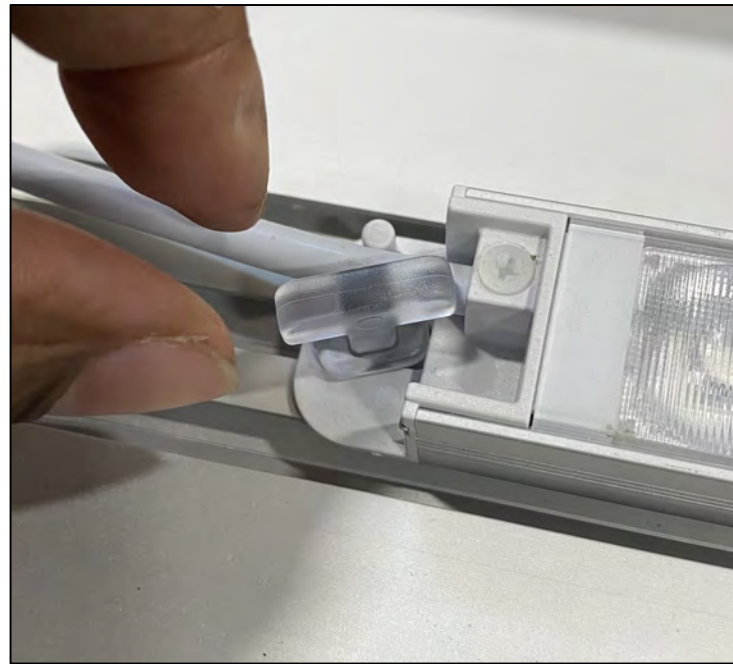

### STEP-2

Rotate the twist clips 90 degrees at both ends to secure to the extrusion.

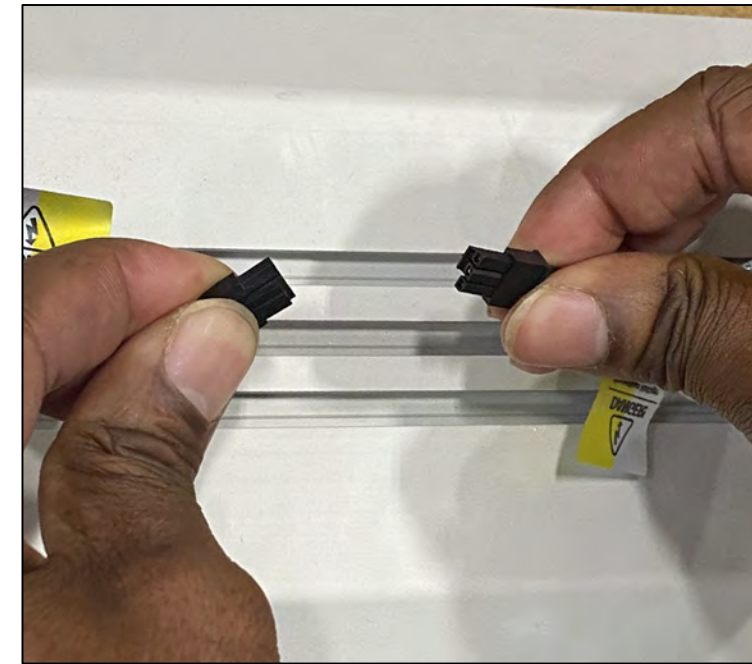

### STEP-3

Connect the lead at both ends of the LED fixture as shown. Take note of male and female ends.

SETUP#	#	DESCRIPTION
CB10	8	CB10 90 DEGREE CONNECTOR
A5	4	900MM (35.43in) LENGTH OF 348 SILVER EXTRUSION-WITH MITRE CUT BOTH ENDS
IB2-O	4	JOINER BAR (OLD STYLE)
A11	1	1200MM (47.24in) LENGTH OF 348 SILVER EXTRUSION-WITH MITRE CUT LEFT END FOR CB10-IB2 LOCK HOLE RIGHT END-WITH GROMMET HOLE 100MM FROM LEFT END.
A12	3	1200MM (47.24in) LENGTH OF 348 SILVER EXTRUSION-WITH MITRE CUT LEFT END FOR CB10-IB2 LOCK HOLE RIGHT END
A6	3	1200MM (47.24in) LENGTH OF 348 SILVER EXTRUSION-WITH MITRE CUT RIGHT END FOR CB10-IB2 LOCK HOLE LEFT END
A2	2	854MM LENGTH OF PH1 POWDERCOATED EXTRUSION-WITH CAM LOCKS BOTH ENDS
A7	1	1200MM (47.24in) LENGTH OF 348 SILVER EXTRUSION-WITH MITRE CUT LEFT END FOR CB10-IB2 LOCK HOLE RIGHT END-WITH GROMMET HOLE 100MM FROM LEFT END.

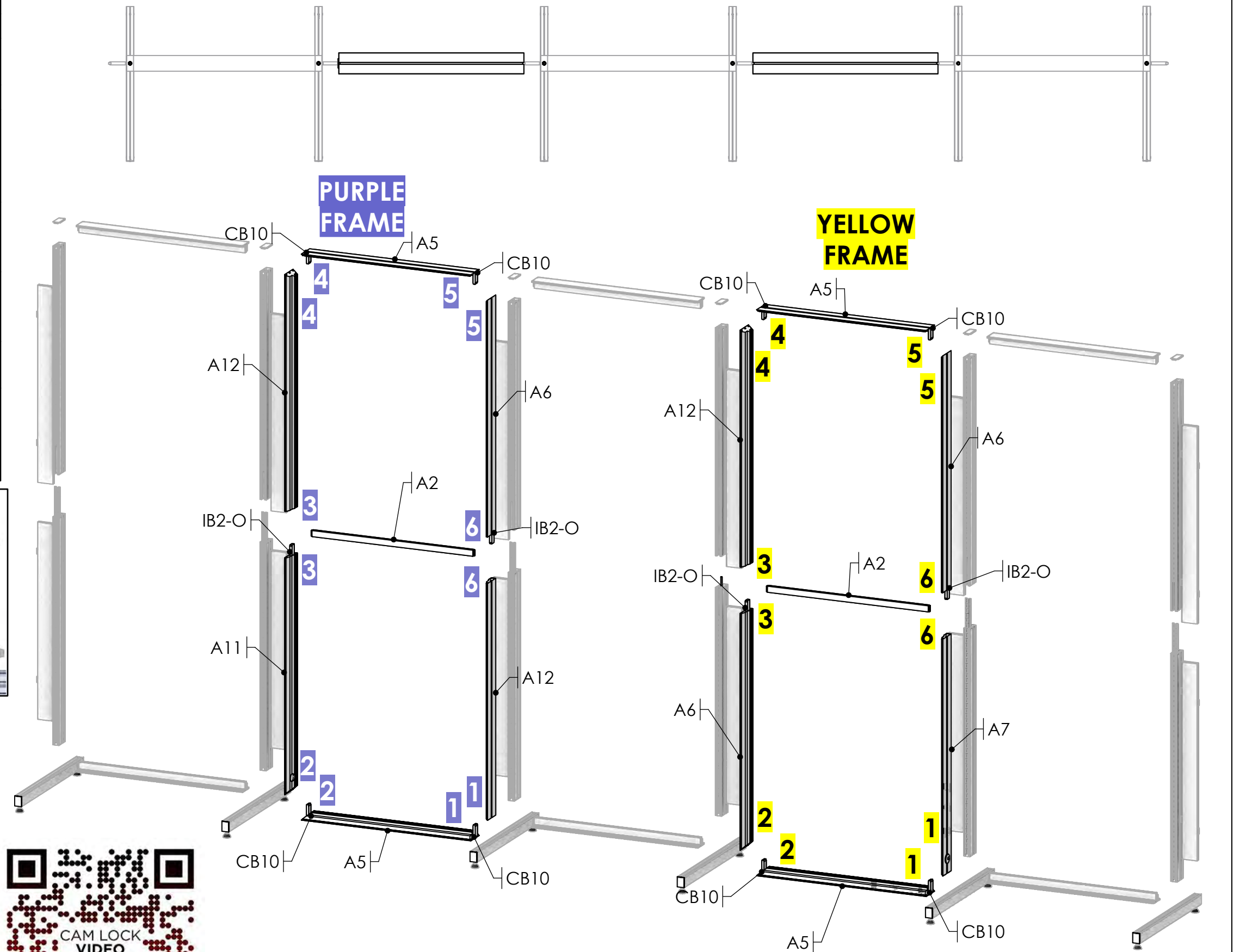
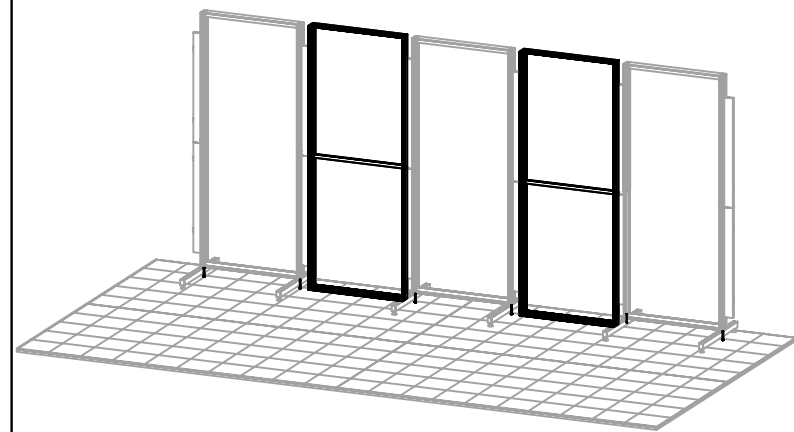
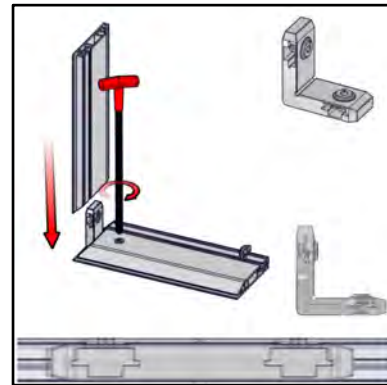
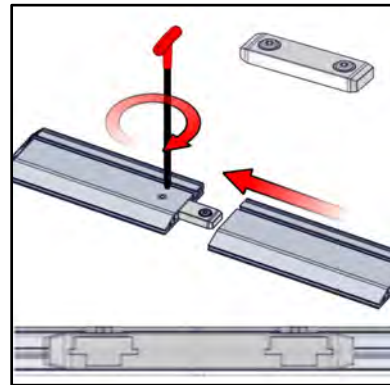

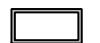
COMPONENTS IN THIS STEP: (Not to scale)	 348	 101 (PH1)
--	--	--



SETUP#	#	DESCRIPTION
LED-EV-THUMB-ORB	48	THUMB KNOB, ORBUS VERSION, FOR LED LIGHT BAR
LED-EV-WHT-6000-19	16	LIGHT BAR (SEG), AC POWER, 6000K, 21" L
LED-EV-WHT-6000-10	8	LIGHT BAR (SEG), AC POWER, 6000K, 14" L



## BUILD X2 UNITS

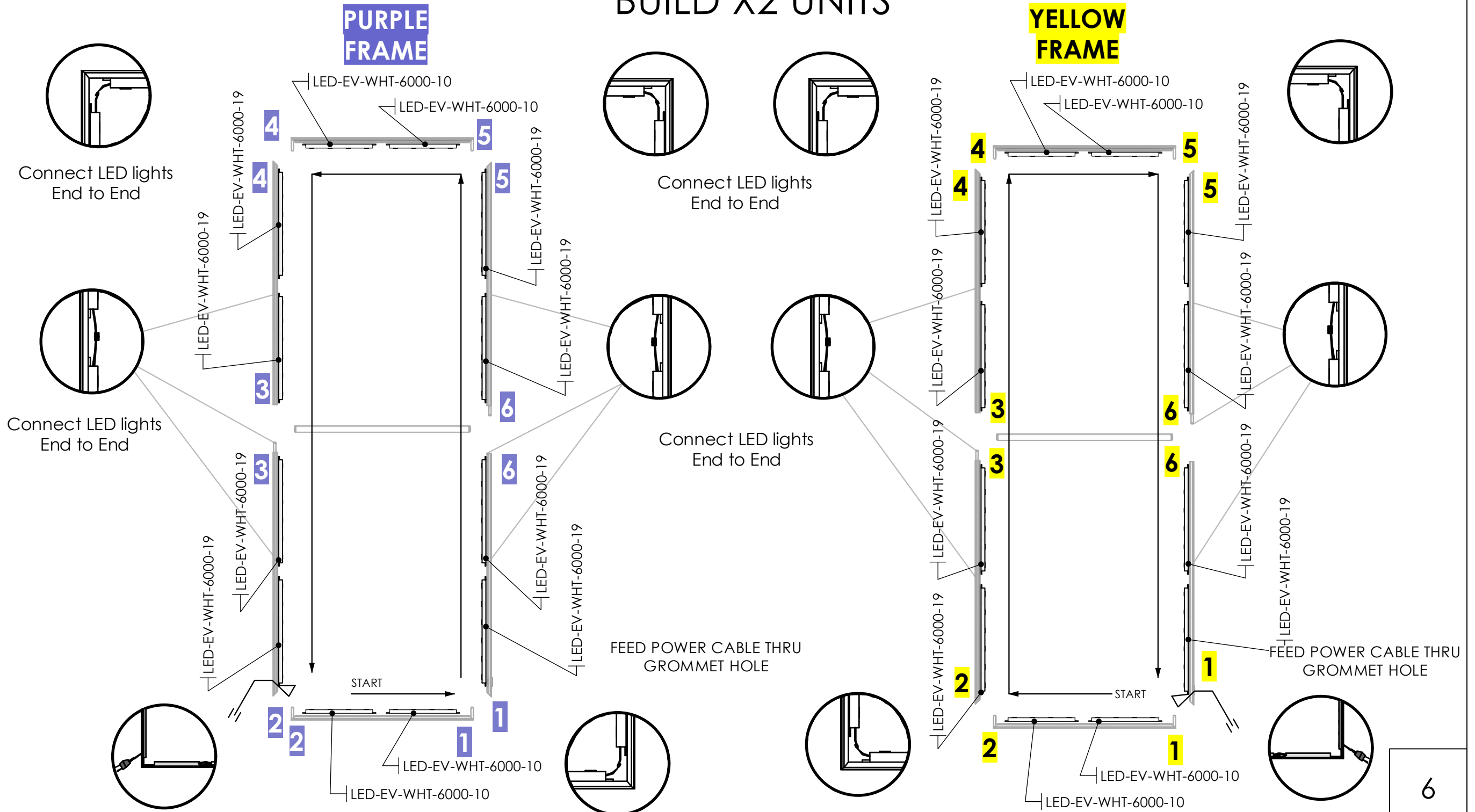

SETUP#	#	DESCRIPTION
CB10	8	CB10 90 DEGREE CONNECTOR
A4	4	400MM (15.75in) LENGTH OF 348 SILVER EXTRUSION-WITH MITRE CUT BOTH ENDS
IB2-O	4	JOINER BAR (OLD STYLE)
A6	3	1200MM (47.24in) LENGTH OF 348 SILVER EXTRUSION-WITH MITRE CUT RIGHT END FOR CB10-IB2 LOCK HOLE LEFT END
A12	3	1200MM (47.24in) LENGTH OF 348 SILVER EXTRUSION-WITH MITRE CUT LEFT END FOR CB10-IB2 LOCK HOLE RIGHT END
A7	1	1200MM (47.24in) LENGTH OF 348 SILVER EXTRUSION-WITH MITRE CUT LEFT END FOR CB10-IB2 LOCK HOLE RIGHT END-WITH GROMMET HOLE 100MM FROM LEFT END.
A1	2	354MM LENGTH OF PH1 POWDERCOATED EXTRUSION-WITH CAM LOCKS BOTH ENDS
A11	1	1200MM (47.24in) LENGTH OF 348 SILVER EXTRUSION-WITH MITRE CUT LEFT END FOR CB10-IB2 LOCK HOLE RIGHT END-WITH GROMMET HOLE 100MM FROM LEFT END.

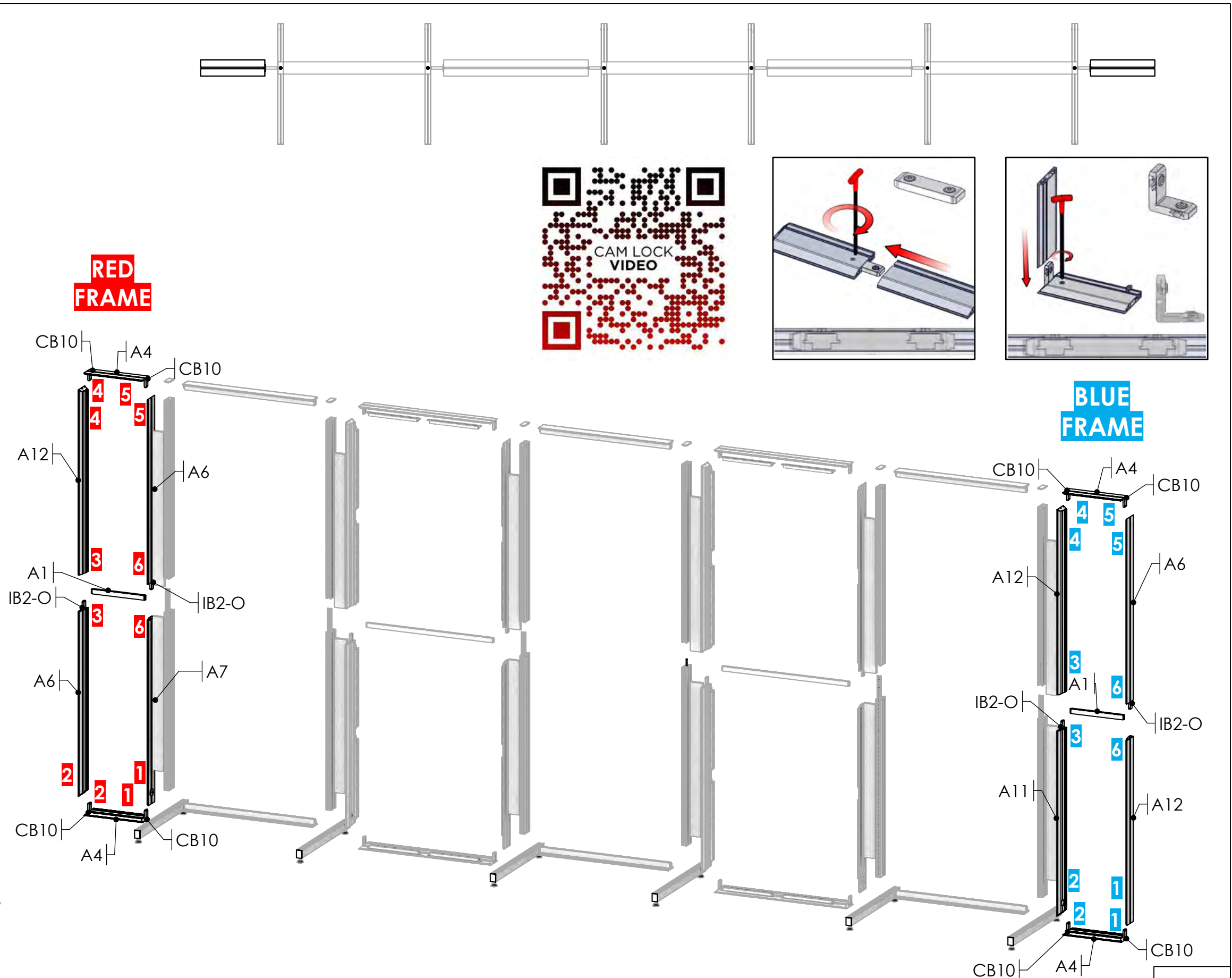
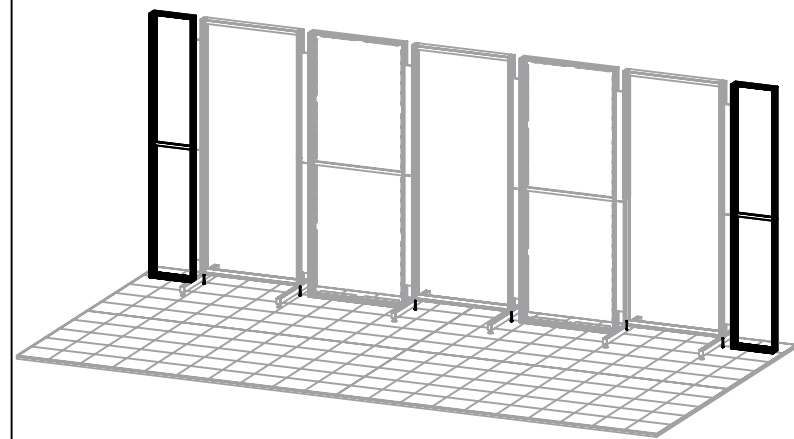

COMPONENTS IN THIS STEP: (Not to scale)		
	348	101 (PH1)





SETUP#	#	DESCRIPTION
E	1	LINER (E) (39.31 w X 98.37 h total size ) 35.31 w X 94.37 h finish size, Opaque Liner, sewn with FCE-2 silicone beading around perimeter & pull tab in bottom right corner
H	1	LINER (H) (39.31 w X 98.37 h total size ) 35.31 w X 94.37 h finish size, Opaque Liner, sewn with FCE-2 silicone beading around perimeter & pull tab in bottom right corner
B	1	LINER (B) (19.63 w X 98.37 h total size ) 15.63 w X 94.37 h finish size, Opaque Liner, sewn with FCE-2 silicone beading around perimeter & pull tab in bottom right corner
K	1	LINER (K) (19.63 w X 98.37 h total size ) 15.63 w X 94.37 h finish size, Opaque Liner, sewn with FCE-2 silicone beading around perimeter & pull tab in bottom right corner

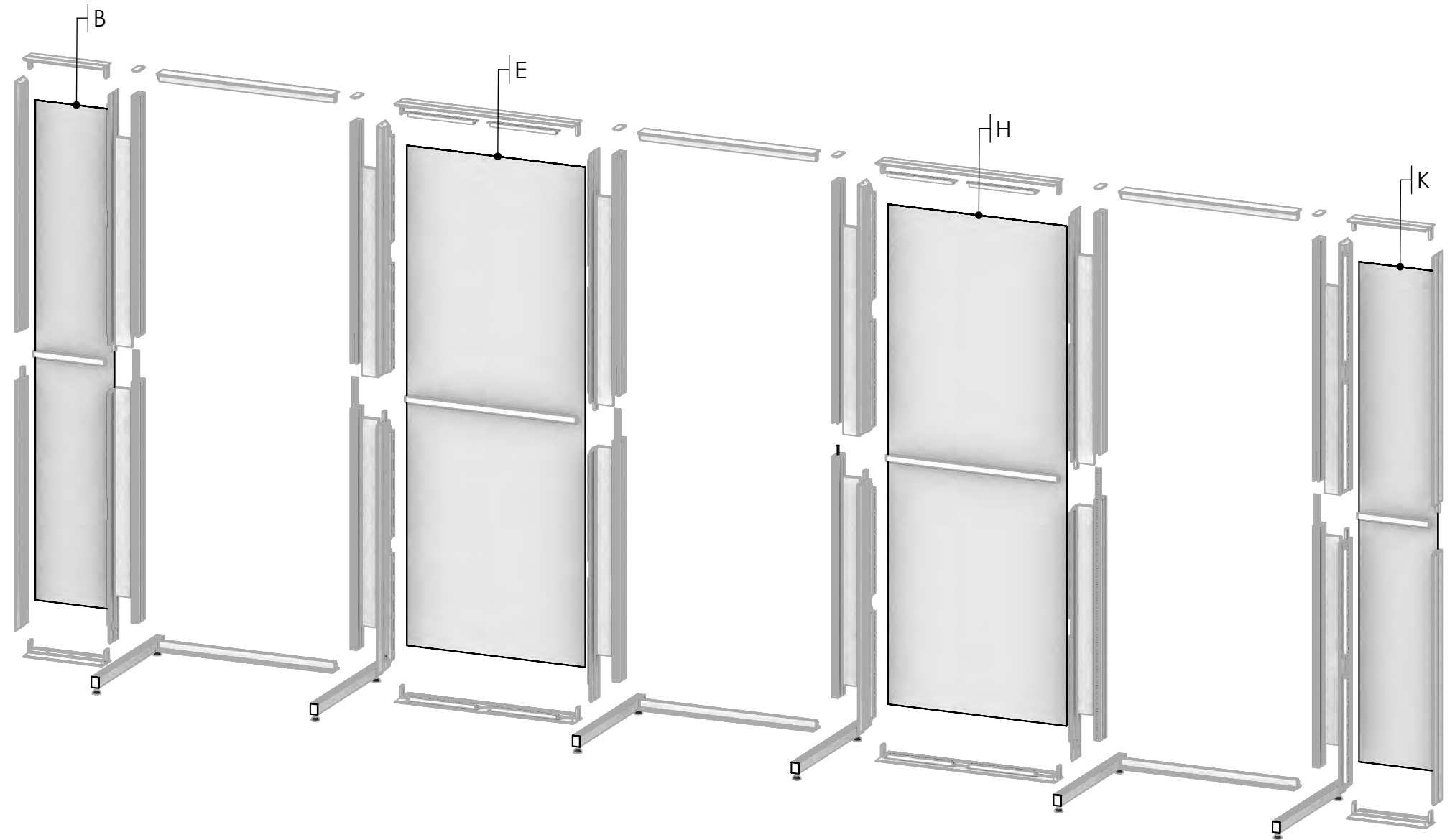
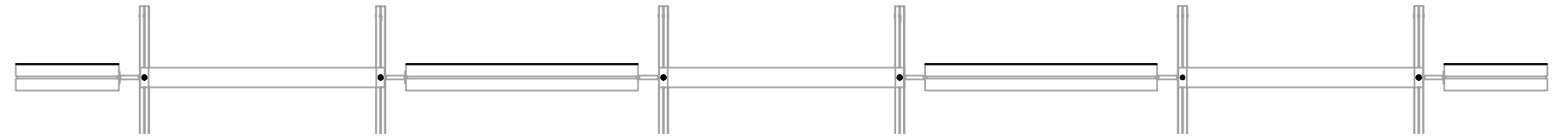

SETUP#	#	DESCRIPTION
F	1	GRAPHIC (F) (39.26 w X 95.04 h total size ) 35.26 w X 91.04 h finish size, Dye-sub print on Eclipse Blockout Stretch, single sided, sewn with FCE-2 silicone beading around perimeter & pull tab in bottom right corner (WITH 1/4" NOTCH LEFT & RIGHT BOTTOM HORIZONTAL SIDE CORNERS)
D	1	GRAPHIC (D) (39.31 w X 98.37 h total size ) 35.31 w X 94.37 h finish size, Dye-sub print on Backlit Textile, single sided, sewn with silicone beading around perimeter & pull tab in bottom right corner
I	1	GRAPHIC (I) (39.26 w X 95.04 h total size ) 35.26 w X 91.04 h finish size, Dye-sub print on Eclipse Blockout Stretch, single sided, sewn with FCE-2 silicone beading around perimeter & pull tab in bottom right corner (WITH 1/4" NOTCH LEFT & RIGHT BOTTOM HORIZONTAL SIDE CORNERS)
C	1	GRAPHIC (C) (39.26 w X 95.04 h total size ) 35.26 w X 91.04 h finish size, Dye-sub print on Eclipse Blockout Stretch, single sided, sewn with FCE-2 silicone beading around perimeter & pull tab in bottom right corner (WITH 1/4" NOTCH LEFT & RIGHT BOTTOM HORIZONTAL SIDE CORNERS)
G	1	GRAPHIC (G) (39.31 w X 98.37 h total size ) 35.31 w X 94.37 h finish size, Dye-sub print on Backlit Textile, single sided, sewn with silicone beading around perimeter & pull tab in bottom right corner
A	1	GRAPHIC (A) (19.63 w X 98.37 h total size ) 15.63 w X 94.37 h finish size, Dye-sub print on Backlit Textile, single sided, sewn with silicone beading around perimeter & pull tab in bottom right corner
J	1	GRAPHIC (J) (19.63 w X 98.37 h total size ) 15.63 w X 94.37 h finish size, Dye-sub print on Backlit Textile, single sided, sewn with silicone beading around perimeter & pull tab in bottom right corner

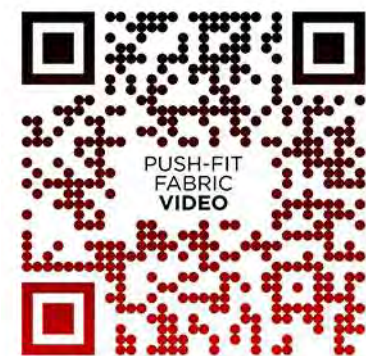
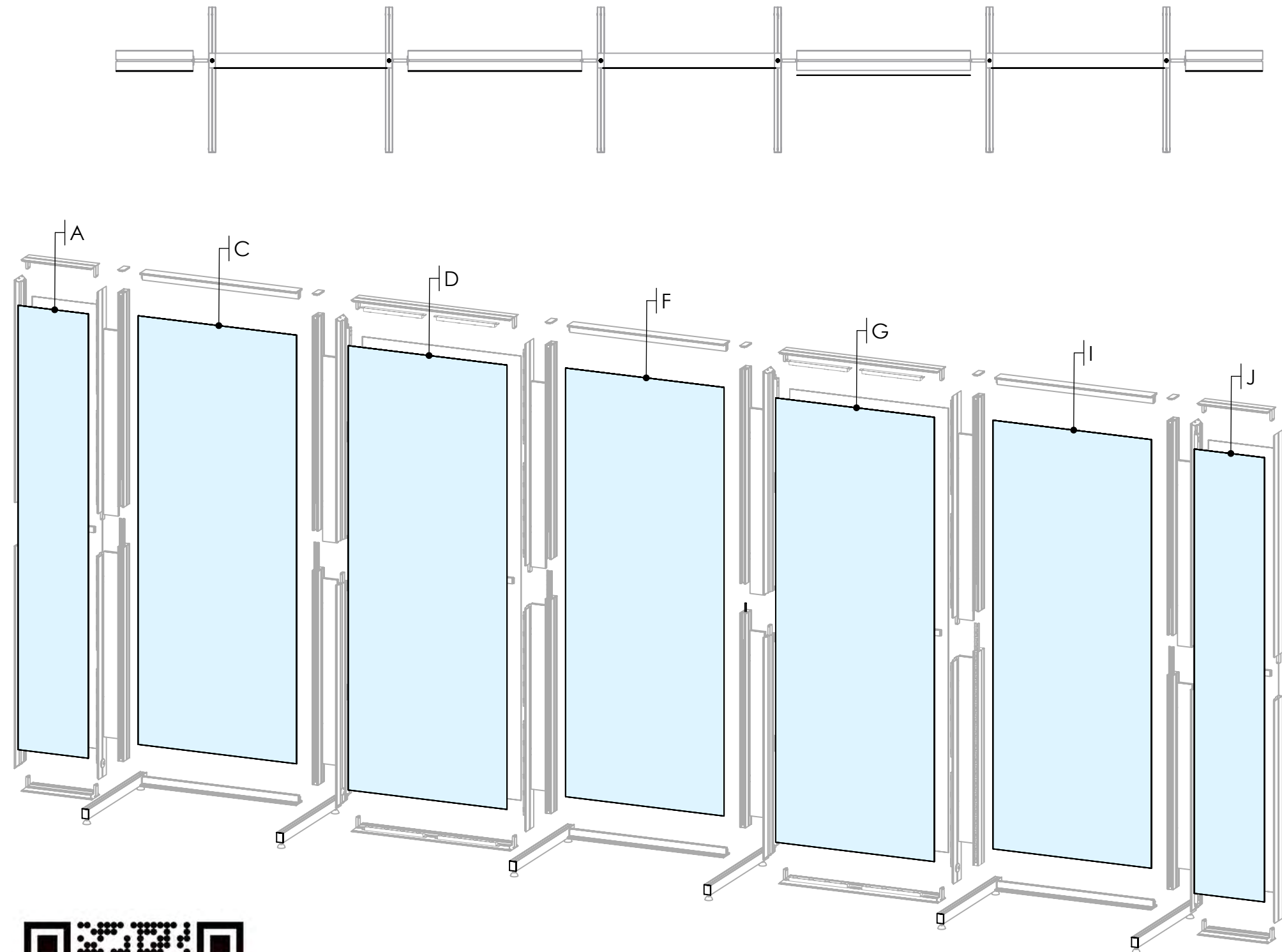

SETUP#	#	DESCRIPTION
MFY-DB-36-17	3	36"W X 17"D DROP IN BASE WITH 2" TOE KICK
MFY-SLF-36-12	6	36"W X 12"D SHELF

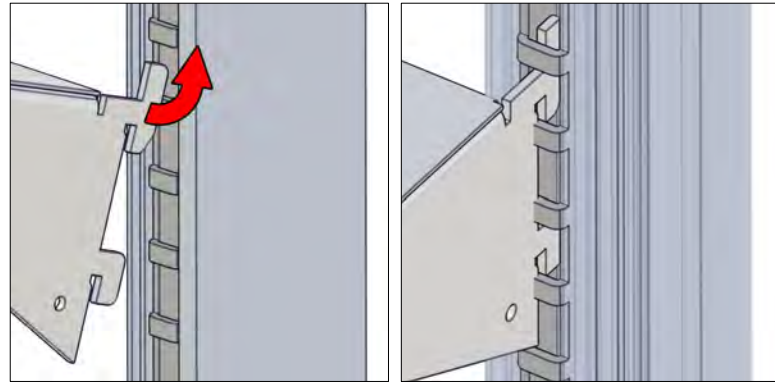

RAISE AND HOOK SHELF INTO PLACE  
 \*\*START WITH BOTTOM SHELVES.

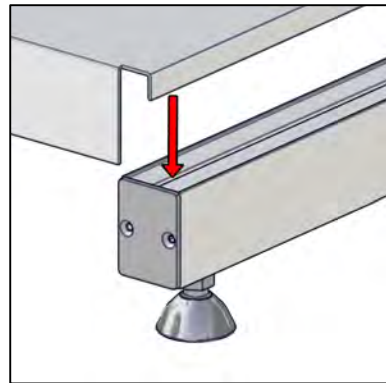

MFY-DB-36-17

PLACE BASE PAN  
 IN GROOVE(FEET)

