

# MODCO 16 - 30X10

MODCO MODULAR EXHIBITS

PRODUCT CODE: MODCO16-30x10G



On frame On graphic

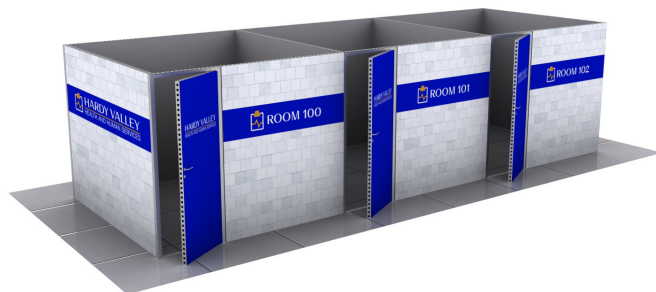
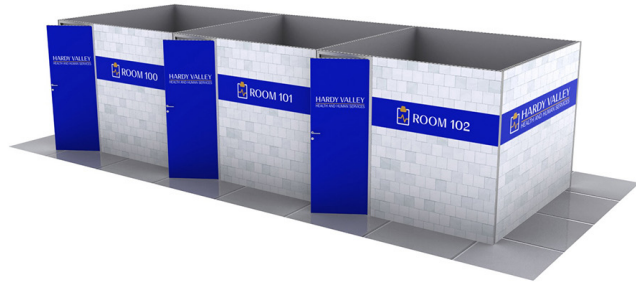

## PRODUCT DESCRIPTION

Modco Modular Display 16 is a three-dimensional 30' x 10' pre-designed configuration featuring three separate 10' x 10' exhibit rooms. Stylish and lively, these rooms are built using tool-free perforated modular aluminum frames. Multiple size frames connect using toolless pin connectors for a quick and easy build. Each room features a door w/ lockset and key. Perforations are completely covered for a flawless finish.

DISPLAY DIMENSIONS	351"W x 95.25"H x 97.25"D		
GRAPHIC SIZES	PANEL	SIZE	QTY
	S	118.375"W x 96.25"H	14
	T	79.25"W x 96.25"H	6
	O	35.25"W x 94.375"H	6
TOTAL PRINTS			26

## GRAPHIC MATERIAL

Stretch Fabric w/ Integrated Block Out

## GRAPHIC FINISHING

Silicone beading is sewn around the perimeter of the fabric graphic. Silicone beading is hidden from view once installed.

## DISPLAY CONSTRUCTION

Aluminum frame and components

## SHIPPING WEIGHTS & DIMENSIONS (FREIGHT ONLY)

Shipping Weight	2014lbs (frame & graphics in crate)
Shipping Dimensions	104"L x 44"W x 54"H (two crates)

## GRAPHIC TURN AROUND TIME

5 business days after proof approval

AVAILABILITY	CA only
--------------	---------

REF	QTY	PART NO.	DESCRIPTION
1	27	MOD-FRM-992x2418	Straight Frame, Corner Screw Connect 992mm x 2418mm
B	120	MOD-PC	Pin Connector
C	8	MOD-90D-CON	90° Connector
D	8	MOD-SM90D-CON	90° Connector
E	36	MOD-CLA-CON	Clamp Connector
AJ	38	MOD-180D-CON	180 Degree Connector
2	3	MOD-DSWL-992x2418	Door Set w/ Lock 992mm x 2418mm
A	2	MOD-PCWP-A	Pin Connector for Door Jamb
H	4	MOD-T-90DCON	T Shape 3 Way 90 Degree Connector Used per Set of 2pcs
AA	10	MOD-DCC-180D	Door Clamp Connector, 180 Degrees (Connect to Wall Frame)
AC	6	MOD-CP-992x2418	Cover Profile for Frame 992x2418. Flat Model. Anodized
AF	12	MOD-CC	Clip Connector Cover Connects Cover Profile
AL	120	MOD-FP	Modco Frame Protector

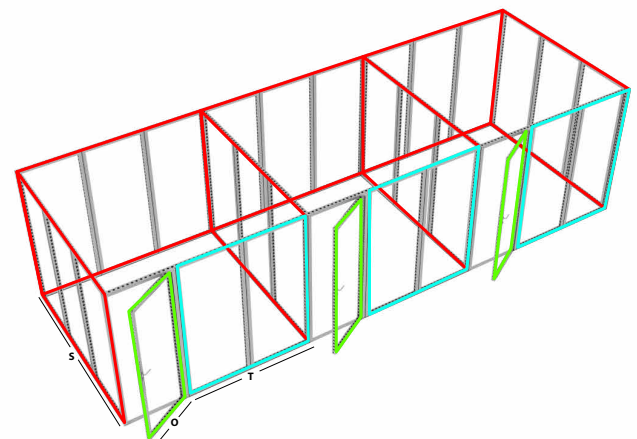

## PARTS REFERENCE

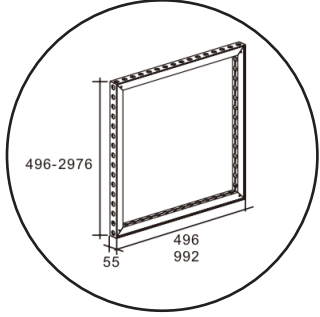

MOD-FRM-992X2418

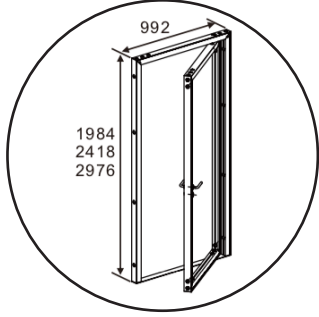

MOD-DSWL-992X2418

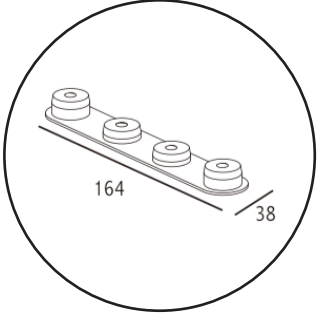

MOD-180D-CON

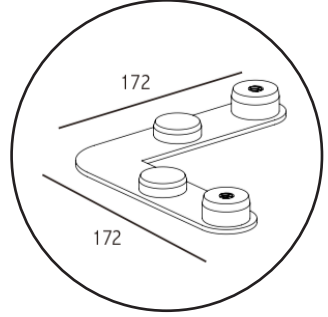

MOD-90D-CON

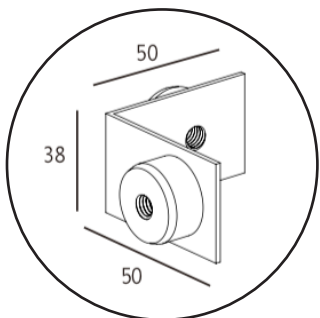

MOD-SM90D-CON

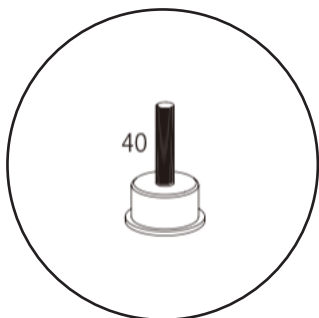

MOD-PCWP-A

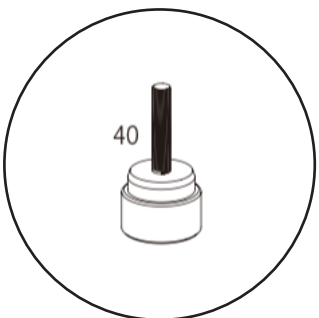

MOD-PC

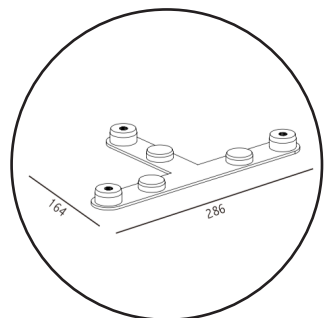

MOD-T-90D-CON

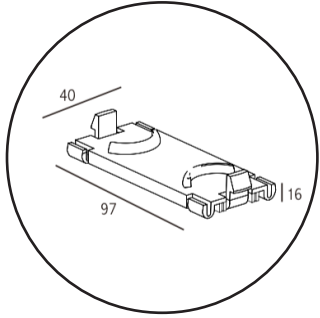

MOD-CC

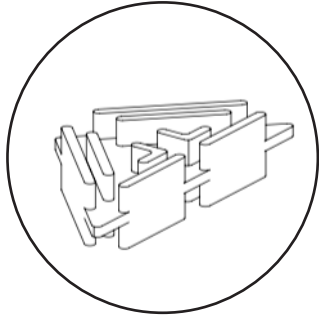

MOD-FP

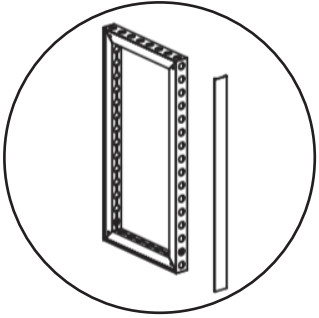

MOD-CP-992X2418

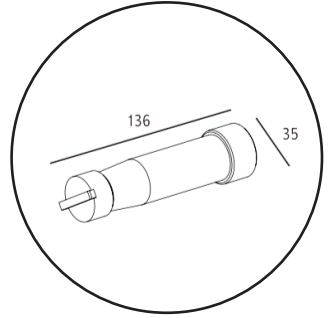

MOD-DCC-180D

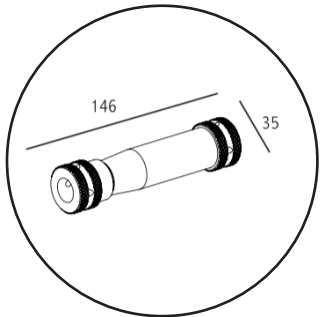

MOD-CLA-CON

## INSTRUCTIONS

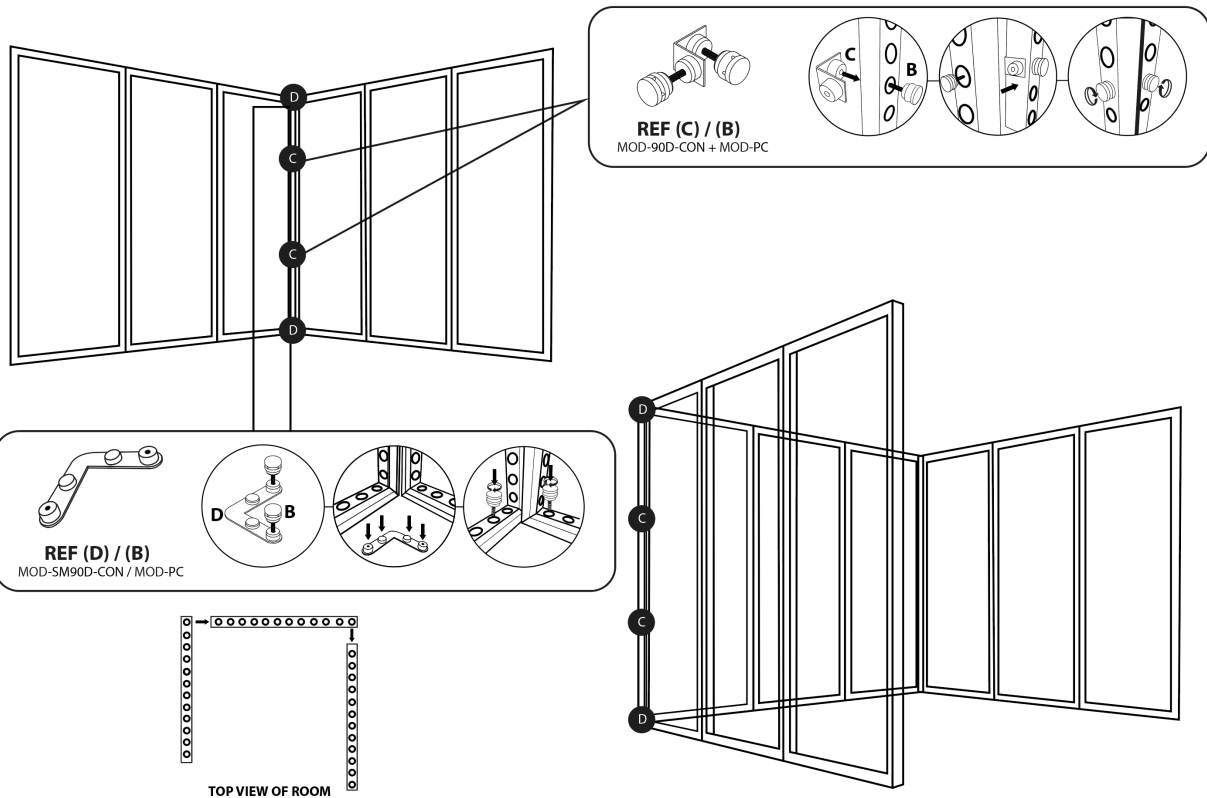
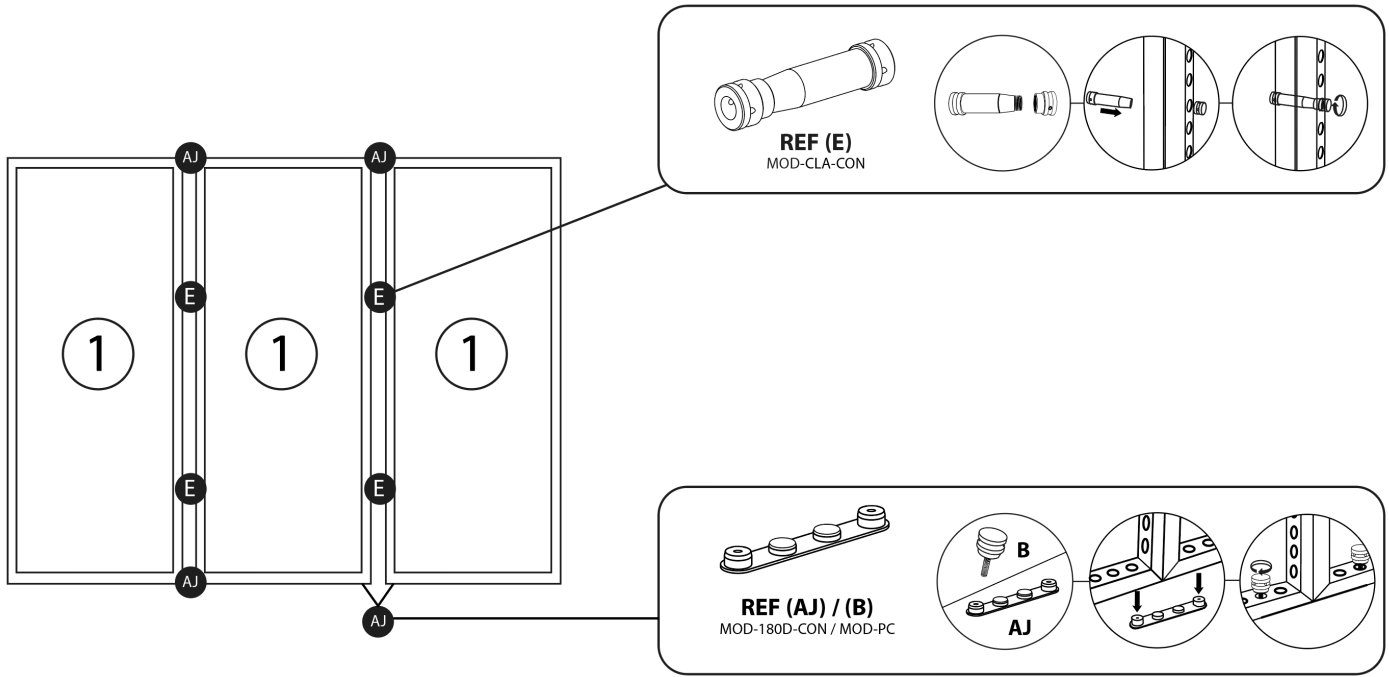

## INSTRUCTIONS

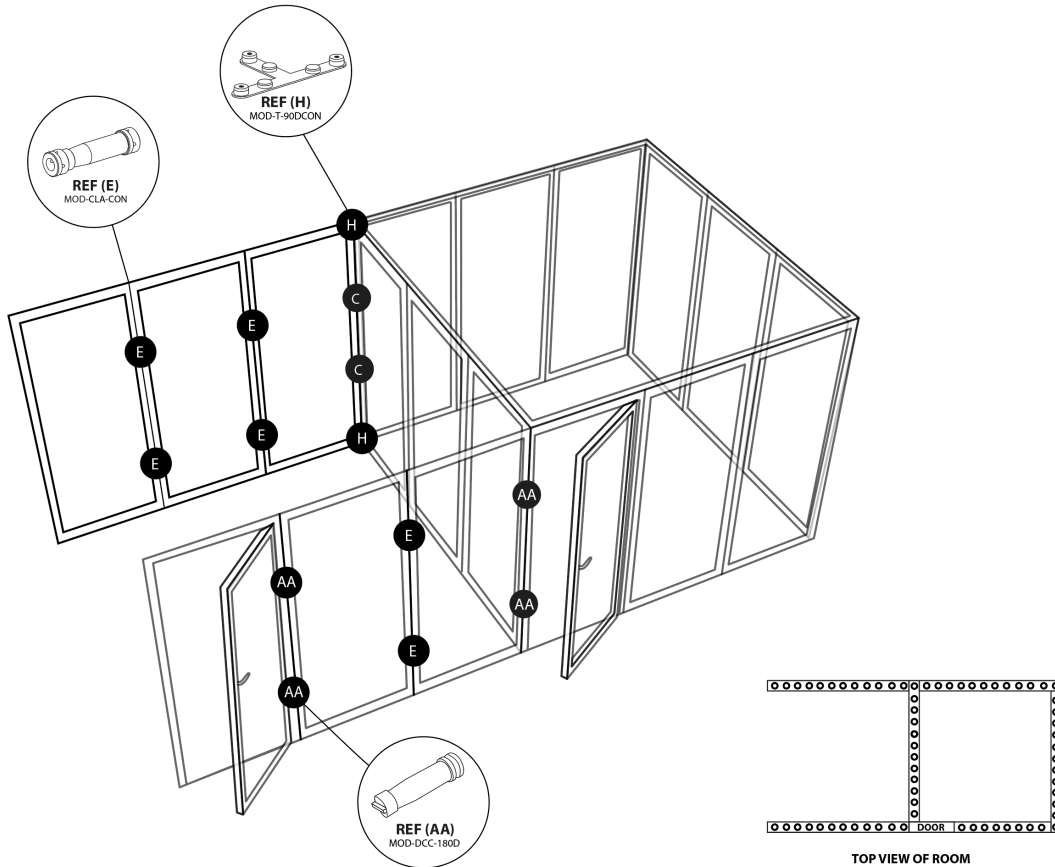
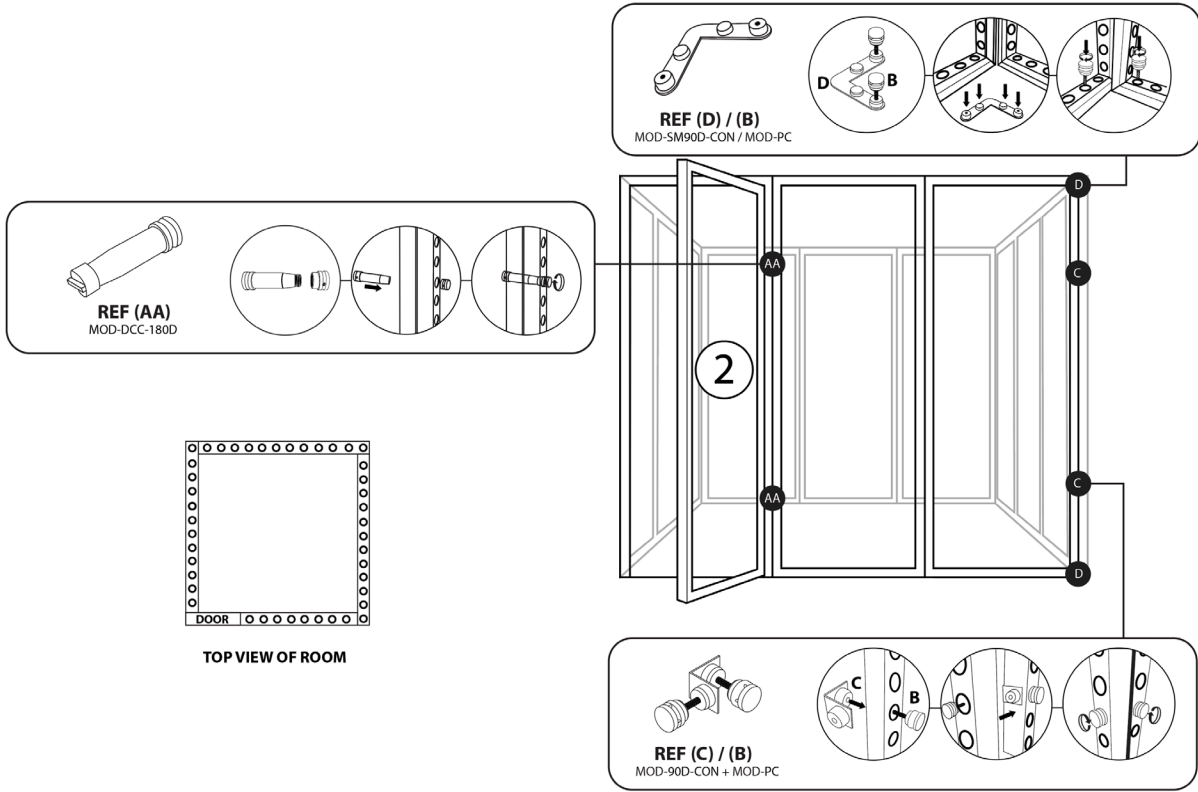

## INSTRUCTIONS

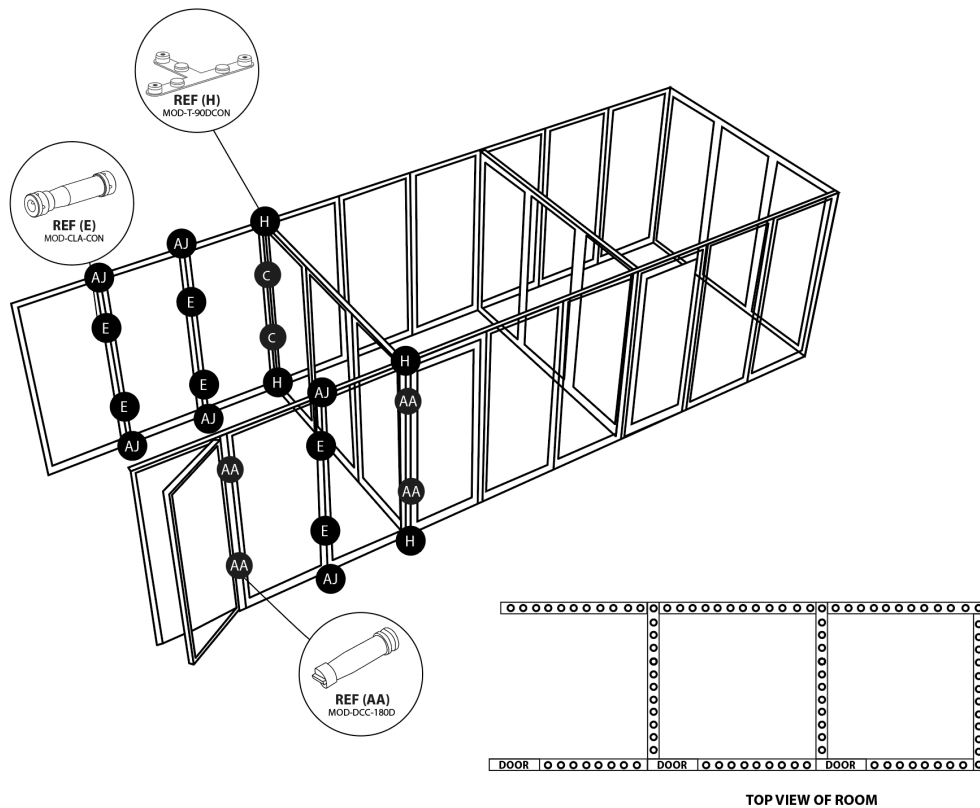
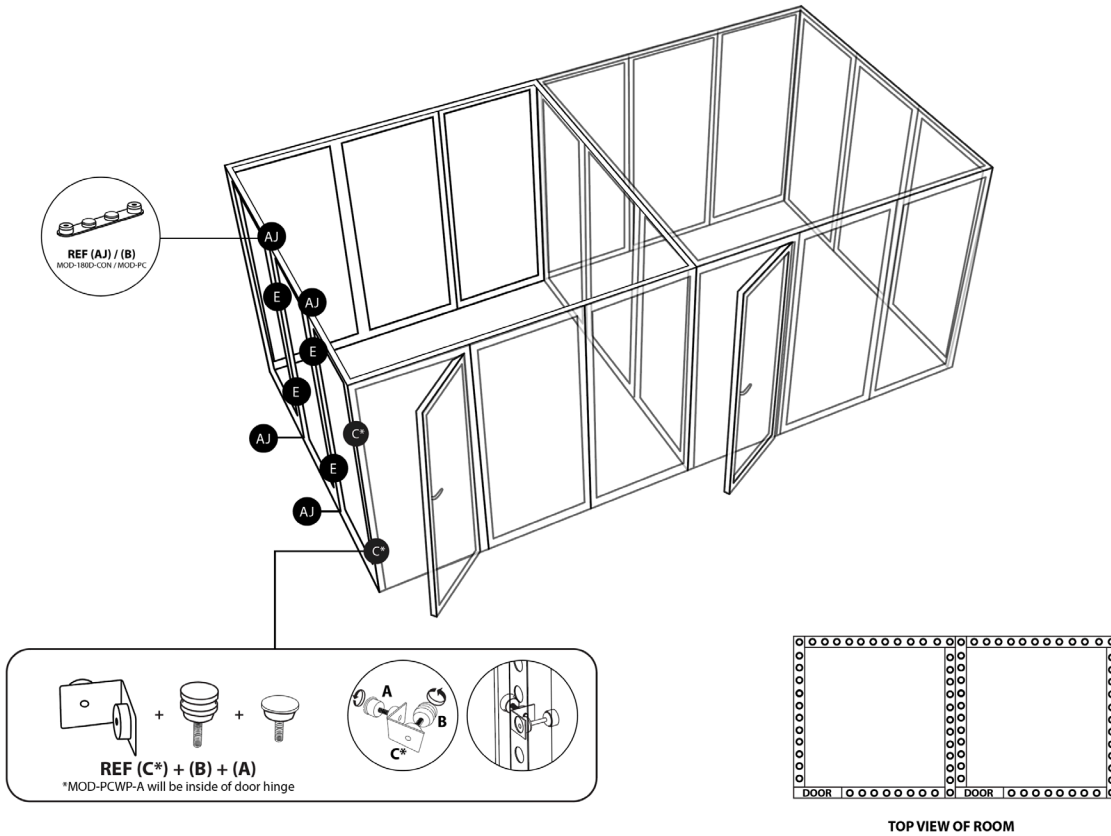

# MODCO 16 - 30X10

MODCO MODULAR EXHIBITS

PRODUCT CODE: MODCO16-30x10G



On frame On graphic

## INSTRUCTIONS

