



# OVERJOYED LIGHTBOX COUNTER

PRODUCT CODE: OJ-LIGHTCOUNTERG



Graphic Package



Hardware Only

## PRODUCT DESCRIPTION

Elevate your marketing and promotional efforts with the One Choice Lightbox Counter, a sophisticated and versatile display solution designed to captivate your audience. Crafted with precision and elegance, this counter seamlessly combines style, functionality, and ease of use. Whether you're showcasing your products at trade shows, exhibitions, or corporate events, the One Choice Lightbox Counter is your key to making a lasting impression.

## FEATURES

### DISPLAY DIMENSIONS

- 39 3/8" W x 40 5/8" H x 16" D

### GRAPHIC DIMENSIONS

- 39.875" W x 39.875" H

### GRAPHIC MATERIAL

- Dye-Sub Backlit Fabric

### GRAPHIC FINISHING

- 12mm x 3mm silicone beading is sewn around the perimeter of the fabric graphic. Silicone beading is hidden from view once installed.

### DISPLAY CONSTRUCTION

- 100mm wide aluminum profile frame w/MDF counter top

## WEIGHTS & DIMENSIONS (WITH STAND & GRAPHICS)

### SHIPPING WEIGHTS

- Graphic Package: 26 lbs
- Graphic Only: 1 lb

### PACKAGE DIMENSIONS

- Graphic Package: 43" L x 13" W x 7" H
- Graphic Only: Poly Bag

## TURNAROUND TIME

### GRAPHIC PACKAGE

- 4 business days after proof approval\*

### AVAILABILITY

- PACIFIC FULFILLMENT CENTER

\*After proof approval. See website for current production times



ON FRAME



ON GRAPHIC



DOUBLE SIDED



INDOOR





# OVERJOYED LIGHTBOX COUNTER

PRODUCT CODE: OJ-LIGHTCOUNTERG



## HARDWARE FEATURES

## MDF COUNTERTOP

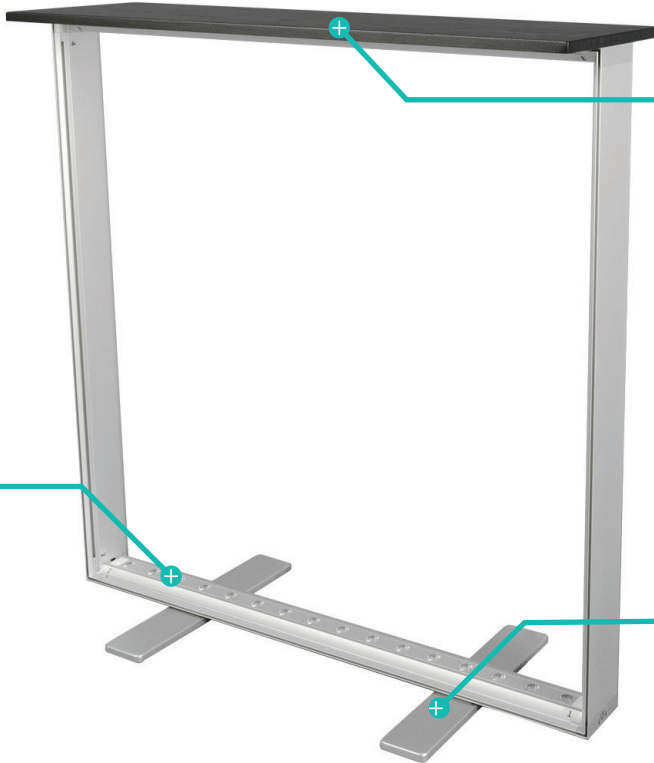

- Simulated wood grain
- Attached to top profile (cannot be removed)

## LED STRIP

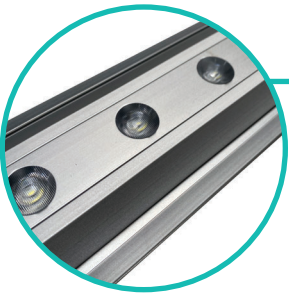

- LED strip pre-installed on bottom profile

## SWIVEL FEET



- Foot Dims
- 16" L x 3" W x 7/16" H
- Attached to bottom profile (cannot be removed)

## LED LIGHTS & TRANSFORMER

### LED SPECS

- Volts: 24V
- Watts: 45W
- Lumens: 230-260 (PER LED)
- CCT: 6500K
- LED Brand: OSRAM
- Beam Angle: 120°
- LED strip qty: 1 Strip on bottom profile

### TRANSFORMER SPECS

- Input (AC): 100-240V~50/60Hz 2.0A
- Output (DC): 24V
- AMPS: 2.5

## TRAVEL BAG



### TRAVEL BAG FEATURES:

- Zipper closure
- 2 Carry Handles
- Foam inserts to hold profiles
- 2 velcro straps to secure all contents
- Holds frame, MDF top, and graphics
- Business card holder on front face

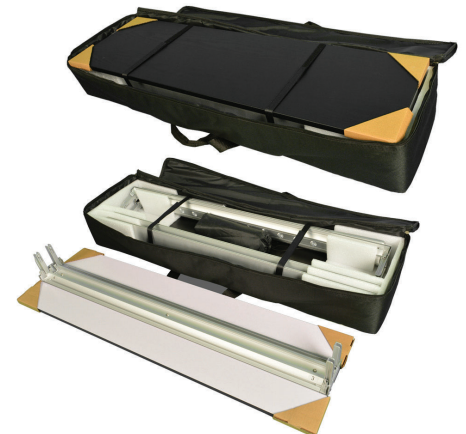



# OVERJOYED LIGHTBOX COUNTER

PRODUCT CODE: OJ-LIGHTCOUNTERG



## PARTS LIST

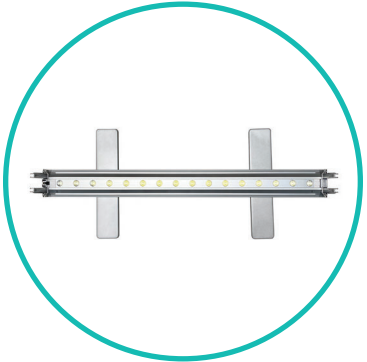

**QTY 1:  
FRAME PROFILE BOTTOM**



**QTY 1:  
FRAME PROFILE LEFT**



**QTY 1:  
FRAME PROFILE LEFT**



**QTY 1:  
COUNTERTOP/TOP PROFILE**

- Countertop Dimensions
- 39 3/8" L x 11 3/8" W x 9/16" H



**QTY 1:  
TRANSFORMER**

- Transformer Cord Length 39" L
- Power Cord Length 108" L



**QTY 1:  
TRANSFORMER BAG**

- Bag Dimensions
- 10" L x 3 1/2" W x 3 1/2" H



**QTY 4:  
PLASTIC CLIP CONNECTORS**



**QTY 1:  
TRAVEL BAG**

- Bag Dimensions
- 42" L x 12" W x 6" H

# OVERJOYED LIGHTBOX COUNTER

PRODUCT CODE: OJ-LIGHTCOUNTERG



## INSTRUCTIONS

- 1 Rotate both feet 90°

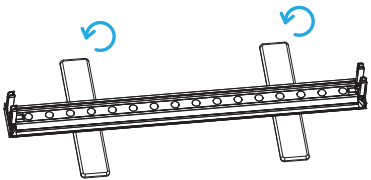

- 2 Connect the transformer

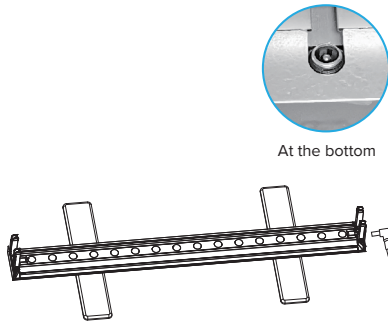

- 3 Match the same numbers together to assemble frame

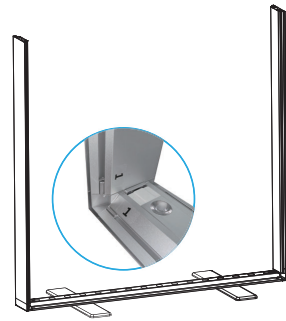

- 4 Place counter top on top of frame

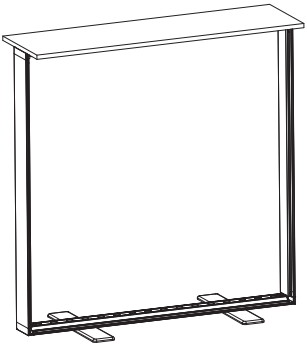

- 5 Install graphics by pressing silicone edge into channels

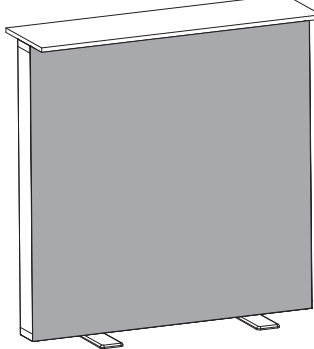

- 5 Connect the power cable then plug into wall outlet

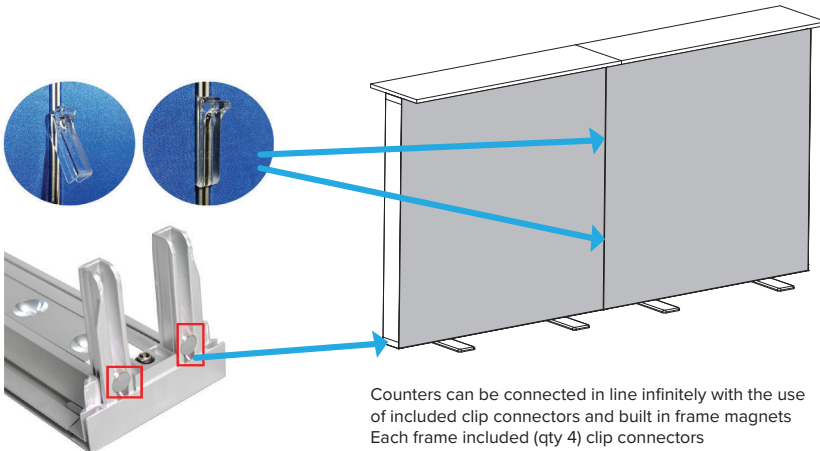

Counters can be connected in line infinitely with the use of included clip connectors and built in frame magnets  
 Each frame included (qty 4) clip connectors  
 (qty 2) Install on front of frames  
 (qty 2) Install on back of frames



# OVERJOYED LIGHTBOX COUNTER

PRODUCT CODE: OJ-LIGHTCOUNTERG



## CARE SHEET - DYE-SUB FABRIC

### HANDLING TIPS

1. If your exhibit fabric has a zipper, please keep zipper closed for storage.
2. Wrinkles can be removed with cool iron or fabric steamer.
3. Fabric should NOT be stored when damp or wet. Store in cool, dry area.
4. For storing graphics please remove from plastic packaging that was provided and keep fabric in cool/dry place.

### WASHING

1. Your fabric graphic can be machine washed. Remove any hardware attached to the fabric prior to cleaning. Use MILD soap and cool water. Air dry fabric, dry on frame if frame is available.
2. Fabric must be COMPLETELY dry prior to storing.
3. DO NOT DRY CLEAN

### STAIN TREATMENT

1. Treat stain from backside of fabric.
2. Remove as much debris as possible with a soft bristle brush (do NOT rub too hard).
3. Use a clean, lint-free white cloth. Lightly pat the stain from the outside moving in (to keep stain from spreading).
4. If a cleaning solution is used, rinse the area well with water to ensure NO solution is left on fabric.
5. Most stains can be treated with household fabric stain removers. It is ALWAYS important to test how the solution will react to the fabric. This can be tested by dabbing solution to a small corner of the fabric. Most household cleaners will provide treatment instructions depending on the type of stain.



- Wrinkles can be removed from fabric with a cool iron or steamer.



- Fabric can be machine washed - use cold water, delicate cycle.



- Do NOT bleach fabric



- Do NOT tumble dry. Fabric must be air dried on the frame to prevent shrinking.