

Formulate 20' x 20' Island Exhibit - Kit 06

CFAB-K-06

Formulate™ Fusion provides an unparalleled dynamic that elevates and accentuates a message and brand, but also maximizes the return on tradeshow investment. Formulate Fusion is Origin's collection of 20ft x 20ft exhibit kits and custom solutions. A fusion of FORM, FABRIC and FUNCTION, these kits combine organic and architectural shapes with state-of-the-art zipper pillowcase dye-sublimated fabric graphics to create unique, dynamic and functional island space.



features and benefits:

- 20' x 20' island display
- Heavy-duty aluminum frames create a space that fosters traffic flow
- Oval-shaped fabric reception counter provides a functional greeting area
- A curved wall create semi-private meeting/ conference area or projection wall
- Kit includes: frame and dye-sublimated zipper pillowcase fabric graphic for three towers, connecting exposed aluminum tube, four oval-shaped sintra graphic panels, reception counter, chip-shaped wall, six monitor mounts, and 1 woodcrate.
- Lifetime hardware warranty against manufacturer defects

dimensions:

Hardware	Graphic
<p>Assembled unit – Fabric Tower Structure: 303" w x 144" h x 42.87" d</p> <p>Chip-wall: 111" w x 96" h x 61.89" d</p> <p>Oval counter: 47.25" w x 38" h x 23.75" d</p> <p>*Additional dimensions on interior pages</p>	<p>Total visual area: Chip wall: Inside – 179" w x 96" h Outside – 181" w x 96" h</p> <p>Oval counter: 57.629" w x 35.424" h</p> <p>Please be sure to include 5" bleed around the perimeter of all graphics.</p>
<p>Shipping</p> <p>Shipping dimensions - ships in 1 woodcrate: 101" l x 49" h x 59" d 2565mm(l) x 1245mm(h) x 1346mm(d)</p> <p>Approximate shipping weight: 1236 lbs / 560.6 kgs</p>	<p>Refer to related graphic template for more information.</p> <p>Visit: www.exhibitors-handbook.com/graphic-templates</p>

additional information:

Graphic material: Dye-sublimated zipper pillowcase fabric and sintra panels

Internal LED lights are not included, can be purchased a la carte.

6 monitor mounts - max monitor sizes and weights can vary

*Monitors and flooring not included



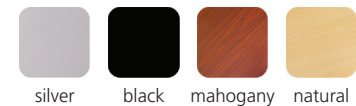

Base Finishes:



We are continually improving and modifying our product range and reserve the right to vary the specifications without prior notice. All dimensions and weights quoted are approximate and we accept no responsibility for variance. E&OE. See Graphic Templates for graphic bleed specifications.

1. Redesign of this exhibit without approval by Manufacture may result in dangerous and unsafe structures. Manufacture disclaims any responsibility for redesigned exhibits it does not approve in writing.

2. Parts and components such as panels and extrusions are manufactured to metric sizing. Where ever possible sizes have been noted in feet and inches as well as in metric. Below is the imperial to metric sizing table as reference. "Nominal" refers to approximate size.

- 2400mm = (94 1/2")
 - 2100mm = (82 5/8")
 - 1800mm = (70 7/8")
 - 1500mm = (59")
 - 1200mm = (47 1/4")
 - 900mm = (35 1/2")
 - 600mm = (23 5/8")
 - 300mm = (11 7/8")
-  Phone Line / Fax
 -  Internet connection
 -  Outlet
 -  Main Drop (point of distrution)
 -  Wire running under carpet

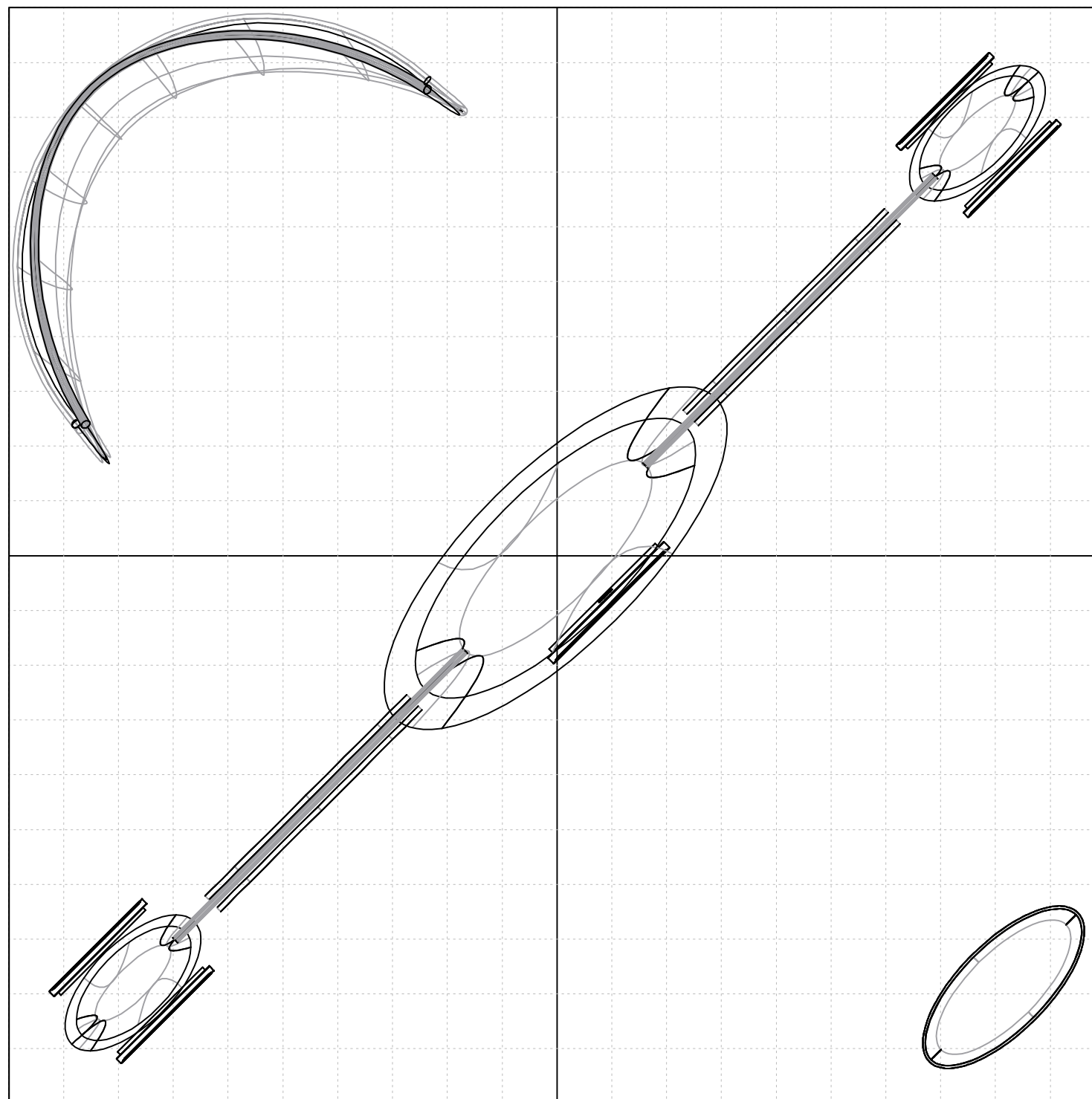

Client:
CFAB-K-5

Title: SET-UP INSTRUCTIONS

FUSION 20 X 20 KIT CFAB-K-06

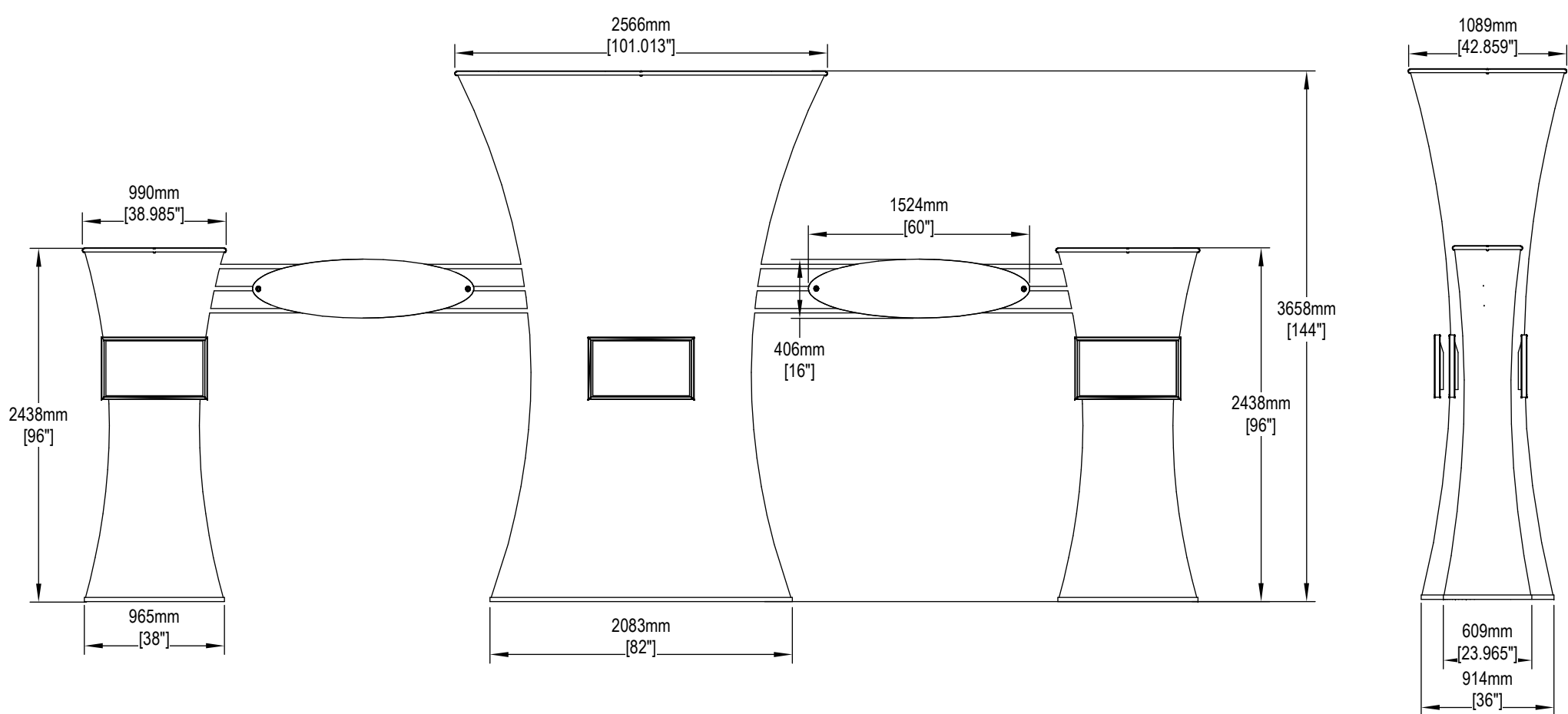
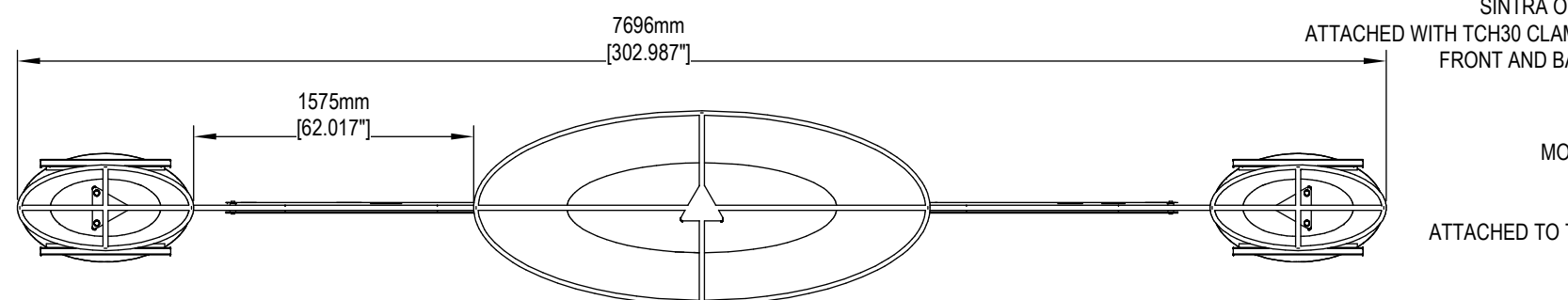
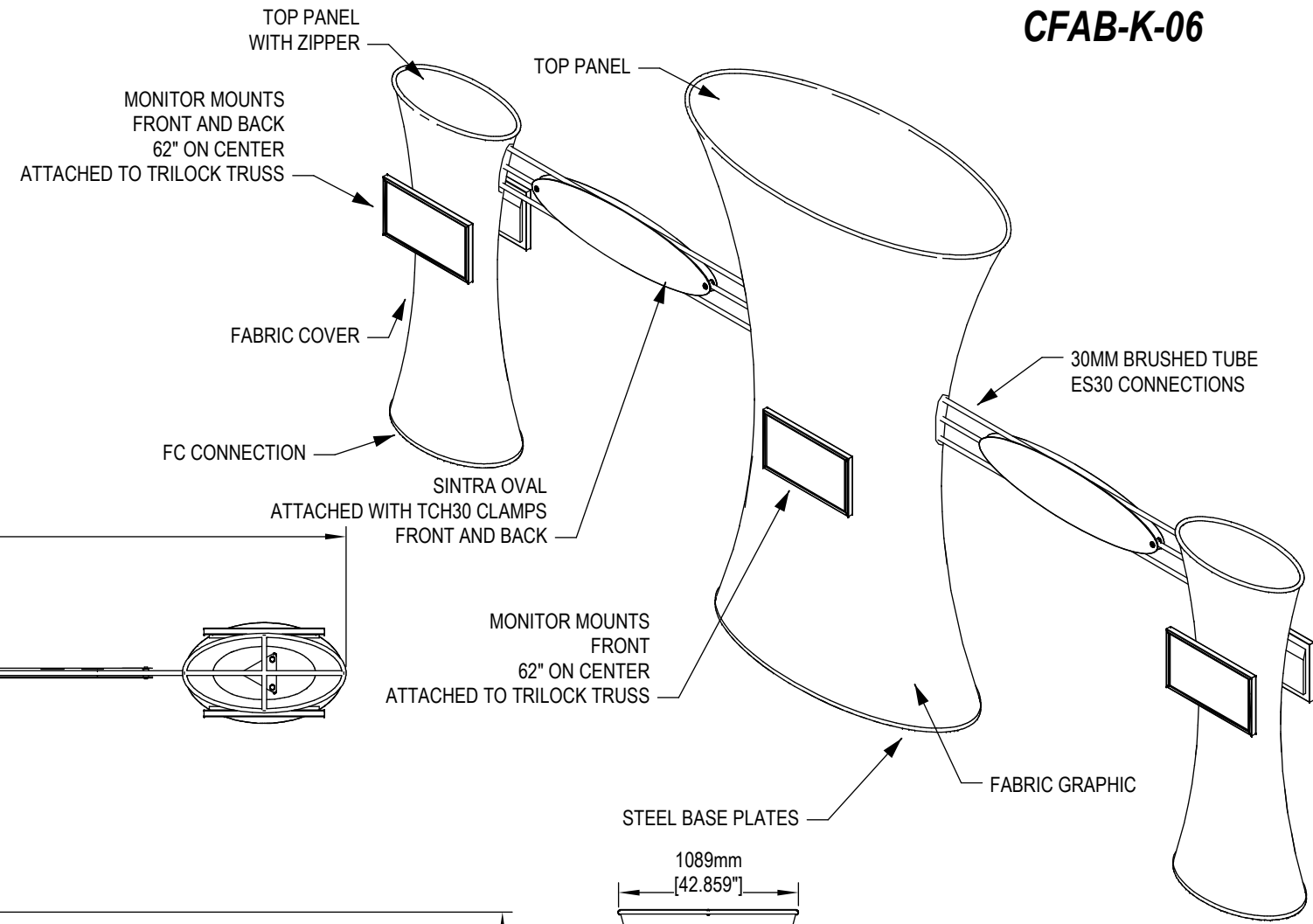

Order #:	
Client	
Dist.	
Dept.	
Man.	
Set up	
Preview	
Ship	
Item	Qty
Packing	
Graphics Size	
Project Manager	
File Name	
Detailer	Date

Description

MAX. ALLOWABLE TOLERANCES
PER 2400mm FABRICATION = ±4mm

CHECKED BY: _____
DATE: _____

SET UP INSTRUCTIONS:

1. CONNECT BOTTOM AND TOP RAILS FOLLOWING THE LABELS
2. CONNECT SIDE RAILS
3. CLEAN THE FRAME AND PLACE THEM ON CLEAN PLACE
4. CAREFULLY REMOVE FABRIC COVER FROM BAGS
5. PLACE COVER AROUND THE BOTTOM OF THE FRAME
6. PULL COVER CAREFULLY UP TO THE TOP
7. CLOSE ALL ZIPPERS
8. ADJUST FABRIC AROUND THE FRAME

BREAK DOWN INSTRUCTIONS:

REVERSE SET-UP STEPS TO BREAKDOWN FRAME

FABRIC CARE INSTRUCTIONS:

1. UNZIP COVER ZIPPERS
2. CAREFULLY REMOVE FABRIC COVER
3. CLOSE ALL ZIPPERS
4. FOLD OR ROLL NEATLY
5. PLACE FABRIC IN COVER BAG

SMALL TOWERS PART LIST:

FOR 2 UNITS

- 12 30MM DIA. TUBE SECTIONS
- 18 ES-30 EXPANDING SPIGOT
- 1 2.5MM HEX KEY
- 2 STEEL BASE PLATES "B"
- 4 TRUSS ENDCAPS
- 22 M8 TRUSS BOLTS
- 2 FABRIC COVER

LARGE TOWERS PART LIST:

FOR 1 UNIT

- 15 30MM DIA. TUBE SECTIONS
- 15 ES-30 EXPANDING SPIGOT
- 1 2.5MM HEX KEY
- 2 TRUSS ENDCAPS
- 1 STEEL BASE PLATES "A"
- 15 M8 TRUSS BOLTS
- 1 FABRIC COVER

USE TRUSS BOLTS AND WING NUTS TO CONNECT TRUSSES

BASE PLATE 'B'

TRUSS WEBBING IS NOT SHOWN FOR BETTER VISIBILITY

BASE PLATE 'A'

Frames 'A' and 'B' Assembly

Assemble frame as shown

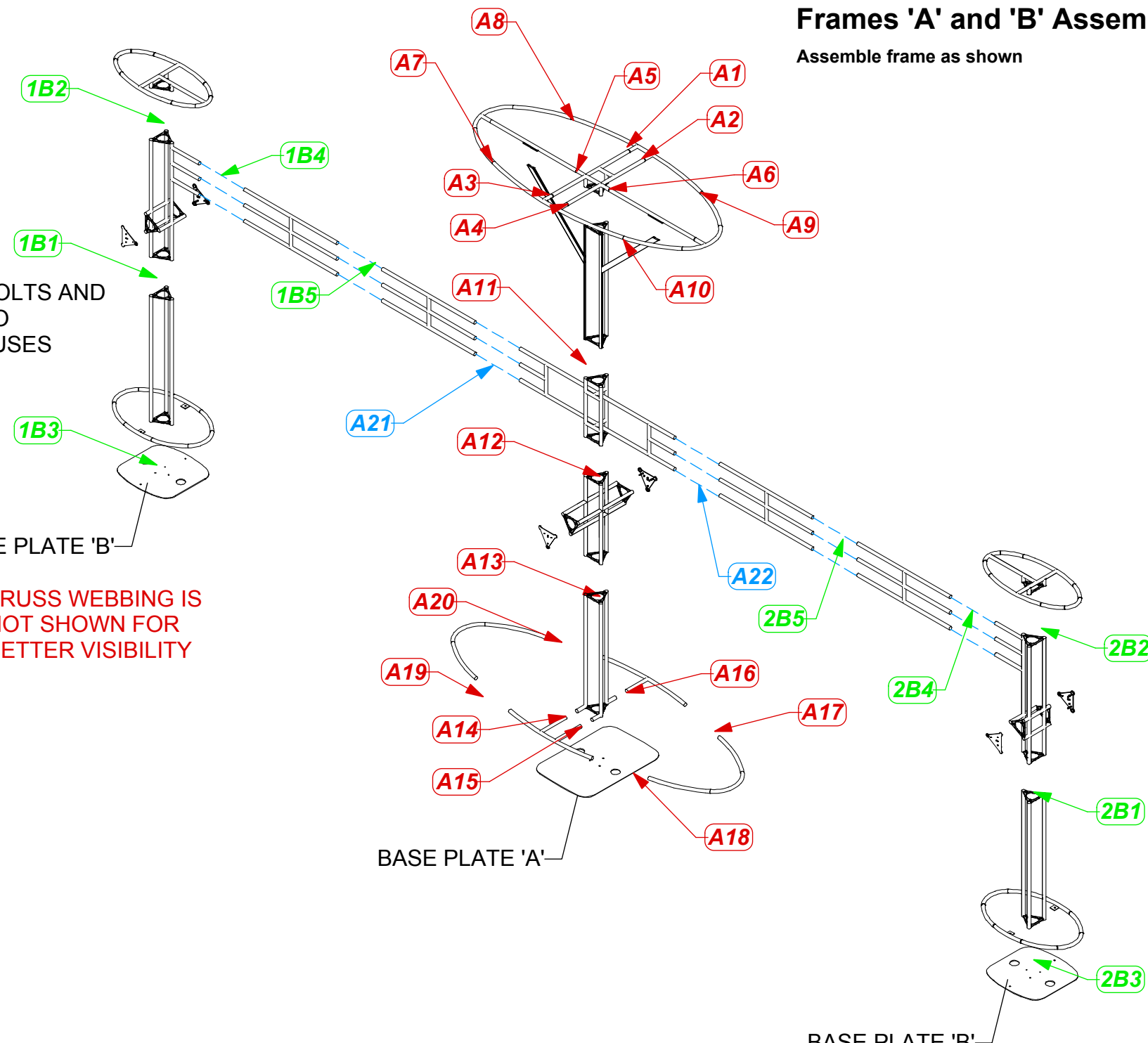

1. Redesign of this exhibit without approval by Manufacture may result in dangerous and unsafe structures. Manufacture disclaims any responsibility for redesigned exhibits it does not approve in writing.

2. Parts and components such as panels and extrusions are manufactured to metric sizing. Where ever possible sizes have been noted in feet and inches as well as in metric. Below is the imperial to metric sizing table as reference. "Nominal" refers to approximate size.

2400mm = (94 1/2")	Phone Line / Fax
2100mm = (82 5/8")	Internet connection
1800mm = (70 7/8")	Outlet
1500mm = (59")	Main Drop (point of distrution)
1200mm = (47 1/4")	
900mm = (35 1/2")	
600mm = (23 5/8")	
300mm = (11 7/8")	

--- Wire running under carpet

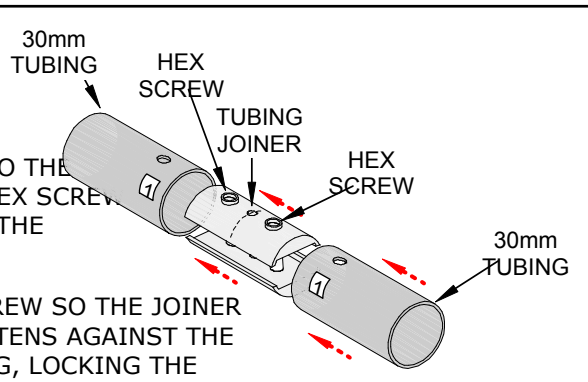

STEP 1
SLIDE THE JOINER INTO THE TUBING SO THE THE HEX SCREWS SITS IN THE HOLE ON THE TUBING

STEP 2
TIGHTEN THE HEX SCREW SO THE JOINER SEPERATES AND TIGHTENS AGAINST THE INSIDE OF THE TUBING, LOCKING THE JOINER AND TUBING TOGETHER

Client: **CFAB-K-5**

Title: SET-UP INSTRUCTIONS

1. Redesign of this exhibit without approval by Manufacture may result in dangerous and unsafe structures. Manufacture disclaims any responsibility for redesigned exhibits it does not approve in writing.

2. Parts and components such as panels and extrusions are manufactured to metric sizing. Where ever possible sizes have been noted in feet and inches as well as in metric. Below is the imperial to metric sizing table as reference. "Nominal" refers to approximate size.

2400mm = (94 1/2")	Phone Line / Fax
2100mm = (82 5/8")	Internet connection
1800mm = (70 7/8")	Outlet
1500mm = (59")	Main Drop (point of distrution)
1200mm = (47 1/4")	
900mm = (35 1/2")	
600mm = (23 5/8")	
300mm = (11 7/8")	

--- Wire running under carpet

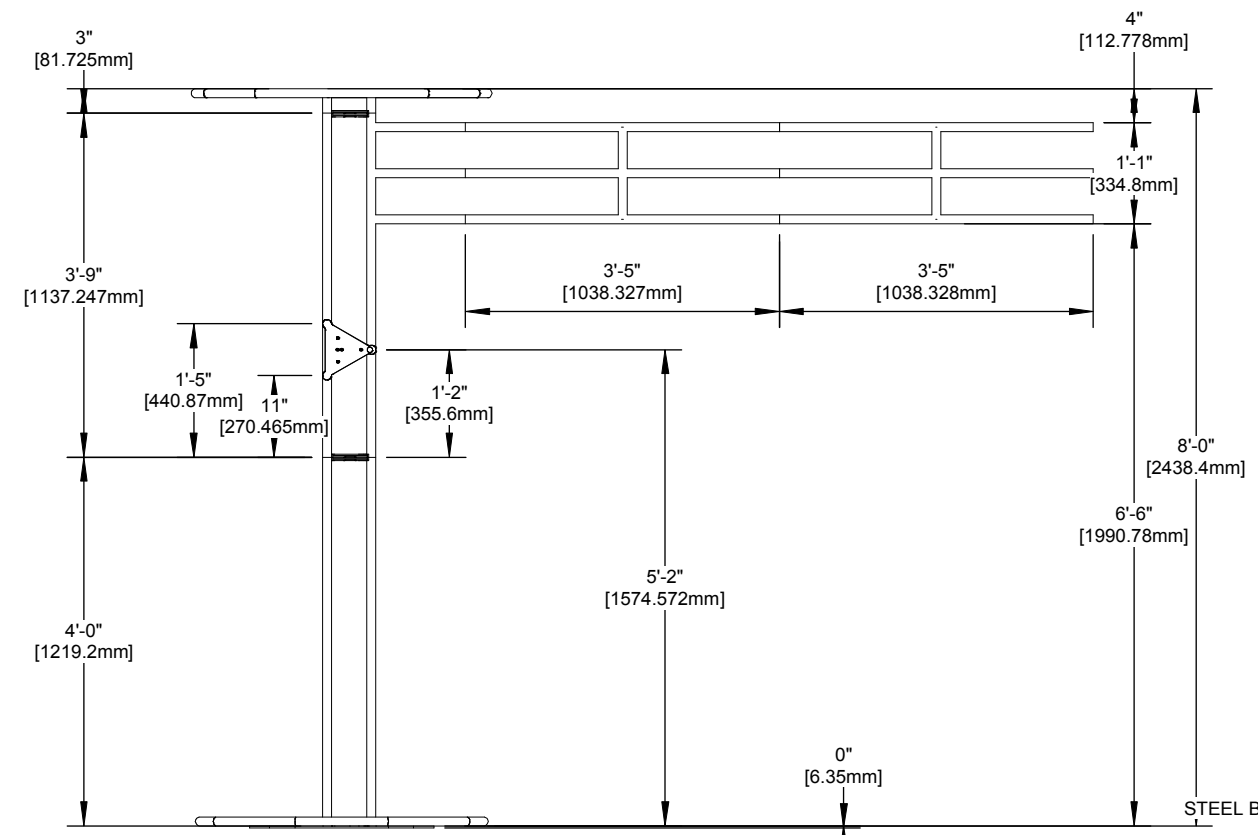

FRONT VIEW

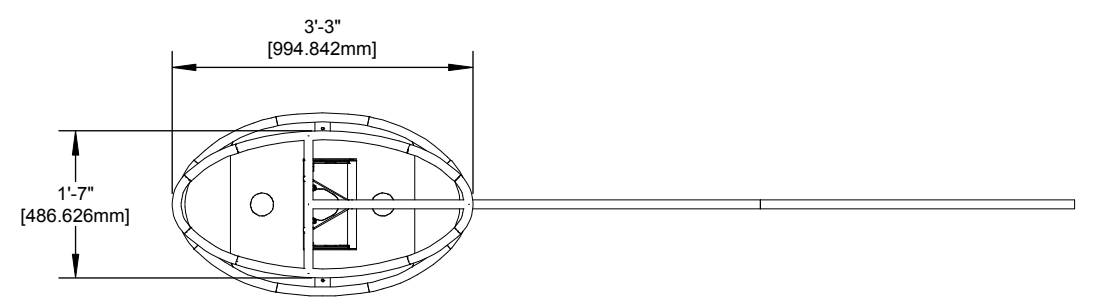

TOP VIEW

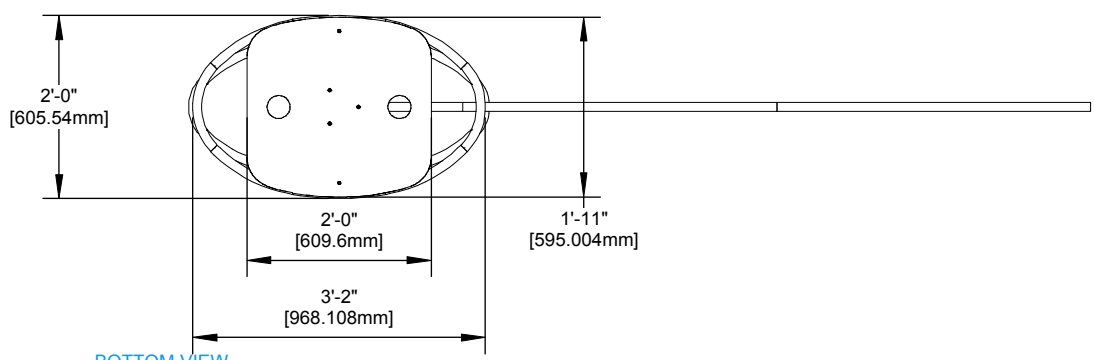

BOTTOM VIEW

1/4" x 2" x 2" TABS WELDED FLUSH TO THE BOTTOM OF THE FRAME AND BOLTED TO THE STEEL BASE PLATE (B)

ISOMETRIC

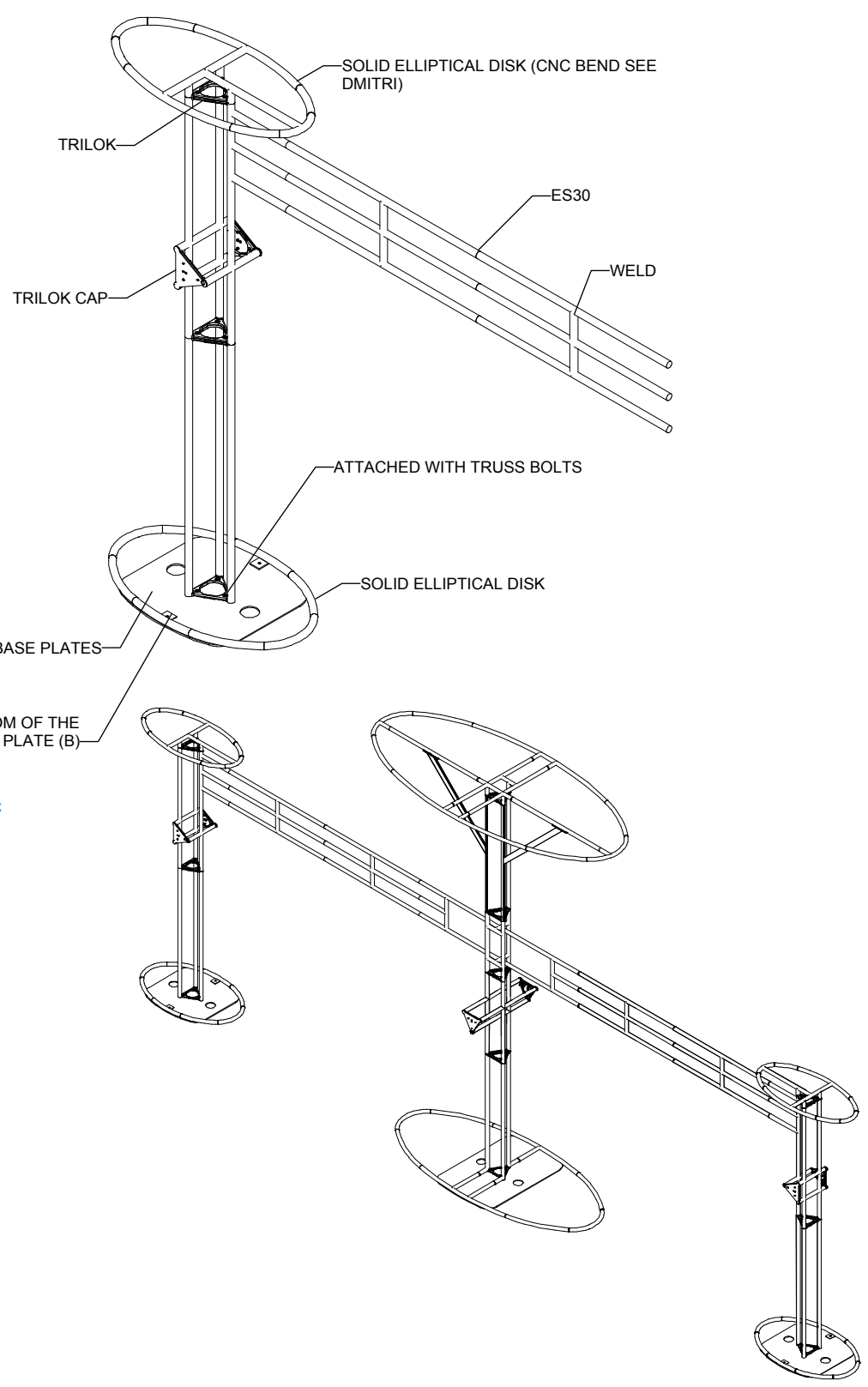

Client: **CFAB-K-5**

Title: SET-UP INSTRUCTIONS



LEFT SIDE



MIDDLE



RIGHT SIDE



HARDWARE

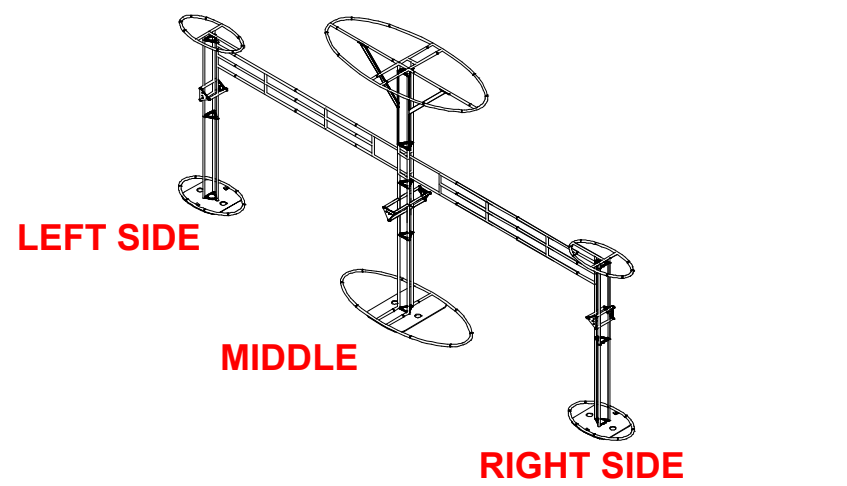

LEFT SIDE

MIDDLE

RIGHT SIDE

1. Redesign of this exhibit without approval by Manufacture may result in dangerous and unsafe structures. Manufacture disclaims any responsibility for redesigned exhibits it does not approve in writing.

2. Parts and components such as panels and extrusions are manufactured to metric sizing. Where ever possible sizes have been noted in feet and inches as well as in metric. Below is the imperial to metric sizing table as reference. "Nominal" refers to approximate size.

- 2400mm = (94 1/2")
 - 2100mm = (82 5/8")
 - 1800mm = (70 7/8")
 - 1500mm = (59")
 - 1200mm = (47 1/4")
 - 900mm = (35 1/2")
 - 600mm = (23 5/8")
 - 300mm = (11 7/8")
- Phone Line / Fax
 - Internet connection
 - Outlet
 - Main Drop (point of distrution)
 - Wire running under carpet

Client: **CFAB-K-5**

Title: SET-UP INSTRUCTIONS

8X



HARDWARE

**TO ATTACH
SINTRA
HEADER**

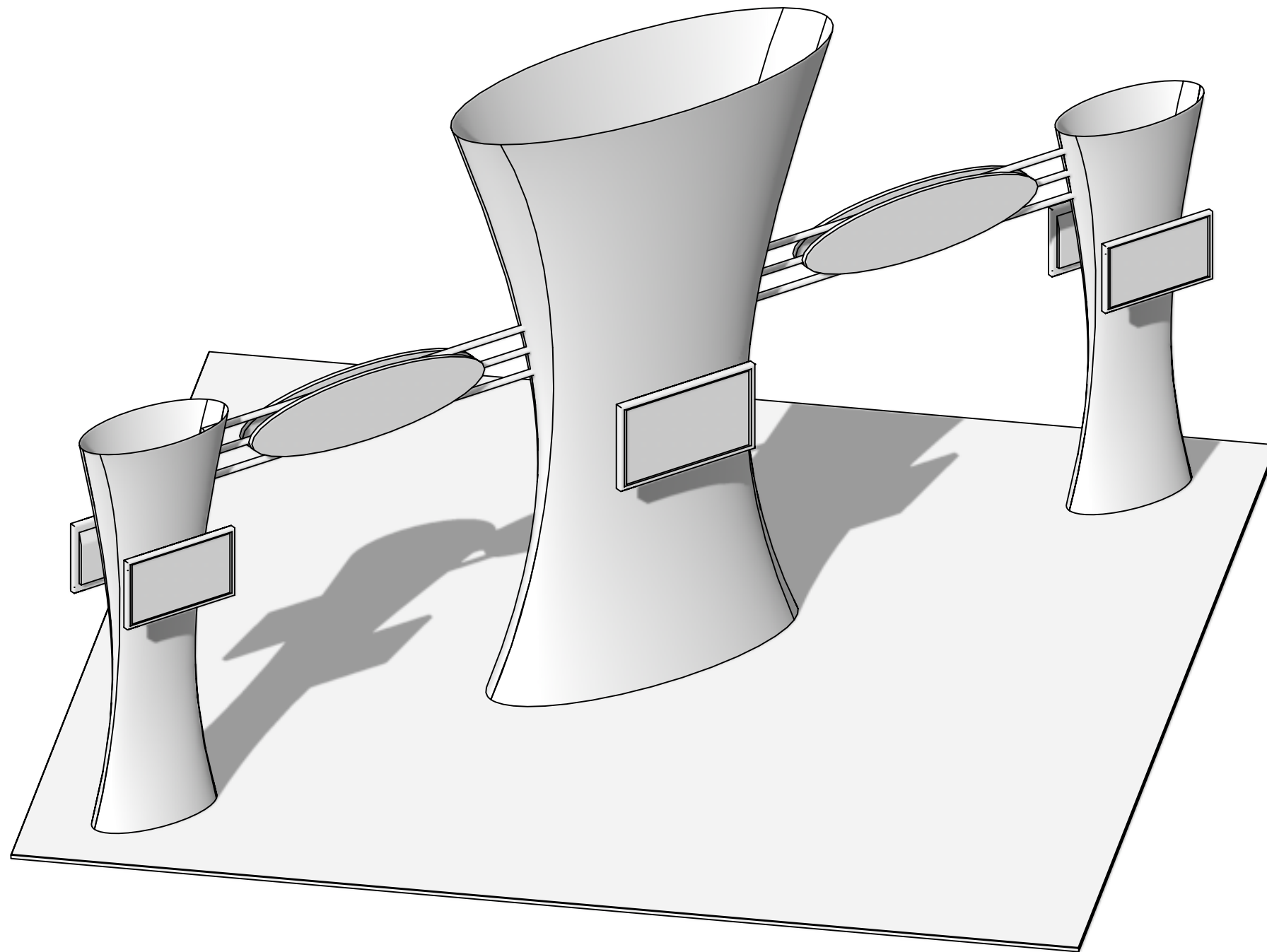

1. Redesign of this exhibit without approval by Manufacture may result in dangerous and unsafe structures. Manufacture disclaims any responsibility for redesigned exhibits it does not approve in writing.

2. Parts and components such as panels and extrusions are manufactured to metric sizing. Where ever possible sizes have been noted in feet and inches as well as in metric. Below is the imperial to metric sizing table as reference. "Nominal" refers to approximate size.

- 2400mm = (94 1/2")
- 2100mm = (82 5/8")
- 1800mm = (70 7/8")
- 1500mm = (59")
- 1200mm = (47 1/4")
- 900mm = (35 1/2")
- 600mm = (23 5/8")
- 300mm = (11 7/8")

- Phone Line / Fax
- Internet connection
- Outlet
- Main Drop (point of distrution)

--- Wire running under carpet

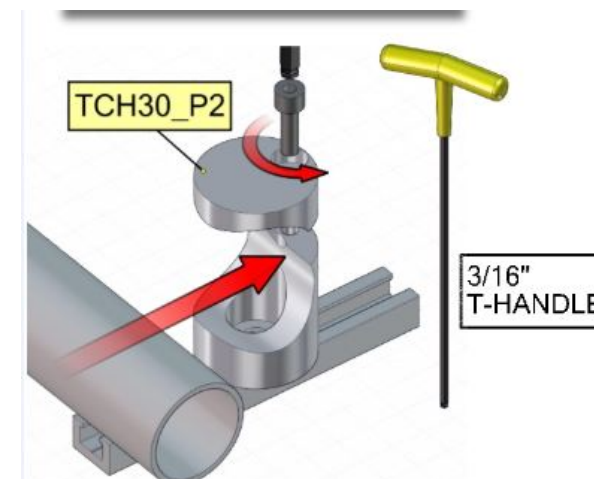

Client: **CFAB-K-5**

Title: SET-UP INSTRUCTIONS

PACKING INSTRUCTIONS



5



4



3



2



1



8



7



6

TOP

- 9 TRILOK / MONITOR MOUNTS
CHIP WALL
HARDWARE ITEMS
FABRIC GRAPHICS
- 8 TRILOK
- 7 TUBES
- 6 TUBES
- 5 TUBES
- 4 TUBES
- 3 TUBES
- 2 CFAB-K-06 - BASES
- 1 FORMULATE COUNTER
W-05-C - BASES

BOTTOM



CASE# 1



BOTTOM

Formulate Chip-Shaped Wall

CHIP-WALL

Formulate™ tension fabric conference walls are lightweight, stylish solutions to your meeting space needs. Ergonomically designed, Formulate C-shaped and Serpentine-shaped walls combine the latest developments in fabric printed technology with gently curved 50mm aluminum frames to create private, cozy and stylish conference areas within any space.

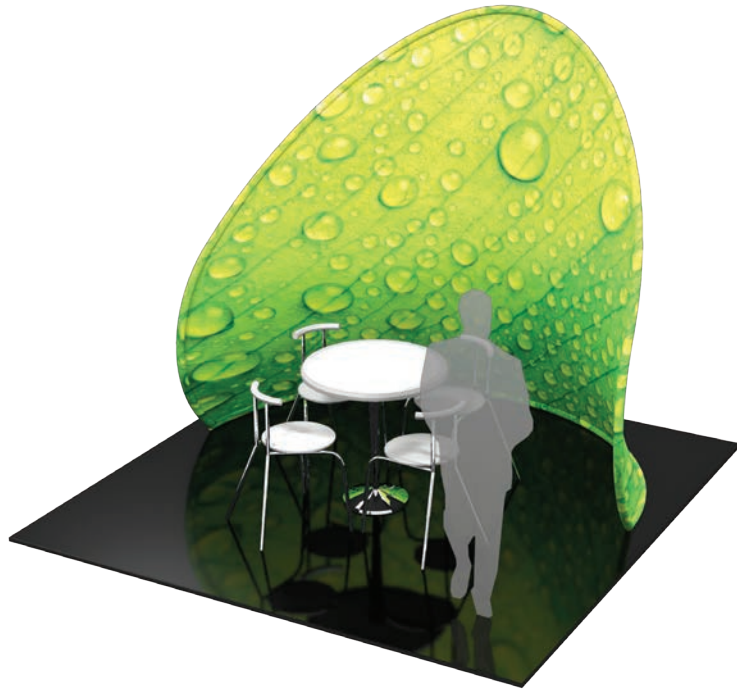

features and benefits:

- State-of-the-art 50mm curved aluminum tube frame with sturdy internal spigots
- Potato chip shaped structure
- Ideal to create a semi-private conference/meeting area or projection wall
- Kit includes: one frame, one dye-sublimated zipper pillowcase graphic, and one wheeled molded OCE storage case
- Lifetime hardware warranty against manufacturer defects

dimensions:

Hardware	Graphic
<p>Assembled unit: 111" w x 96" h x 61.894" d 2819mm(w) x 2438mm(h) x 1572mm(d)</p> <p>Approximate weight (includes graphic): 42.55 lbs / 19.3 kg</p>	<p>Total visual area: Inside: 179" w x 96" h 4547mm(w) x 2438mm(h)</p> <p>Outside: 181" w x 96" h 4597mm(w) x 2438mm(h)</p>
<p>Shipping</p> <p>Shipping dimensions: 1 OCE case: 18" l x 18" w x 40" up to 66" h 457mm(l) x 457mm(w) x 1016mm(h) up to 1675mm(h)</p> <p>Approximate shipping weight (with case): 62.55 lbs / 28.8 kg</p>	<p>Single sided chip walls have inside printed only. Please be sure to include 5" bleed around the perimeter.</p> <p>Refer to related graphic template for more information.</p> <p>Visit: www.exhibitors-handbook.com/graphic-templates</p>

additional information:

Graphic material:
Dye-sublimated zipper pillowcase fabric



www.display-setup-animations.com

We are continually improving and modifying our product range and reserve the right to vary the specifications without prior notice. All dimensions and weights quoted are approximate and we accept no responsibility for variance. E&OE. See Graphic Templates for graphic bleed specifications.

Parts Included		
Part Label	Qty	Part Code
50MM CURVE WITH SPREADER	x1	CHIP-WALL-T3-SP
50MM CURVE	x2	CHIP-WALL-T1
50MM CURVE	x2	CHIP-WALL-T3
50MM CORNER	x2	CHIP-WALL-T2
50MM CURVE	x2	CHIP-WALL-T5
50MM CURVE	x2	CHIP-WALL-T6
30MM CURVED SPREADER	x2	CHIP-WALL-T4
50MM CURVE WITH SPREADER	x1	CHIP-WALL-T7
EXPANDING SPIGOT FOR 30MM TUBE	x2	ES-30
EXPANDING SPIGOT FOR 50MM TUBE	x12	ES-50
CHIP WALL FABRIC GRAPHIC	x1	CHIP-WALL-G

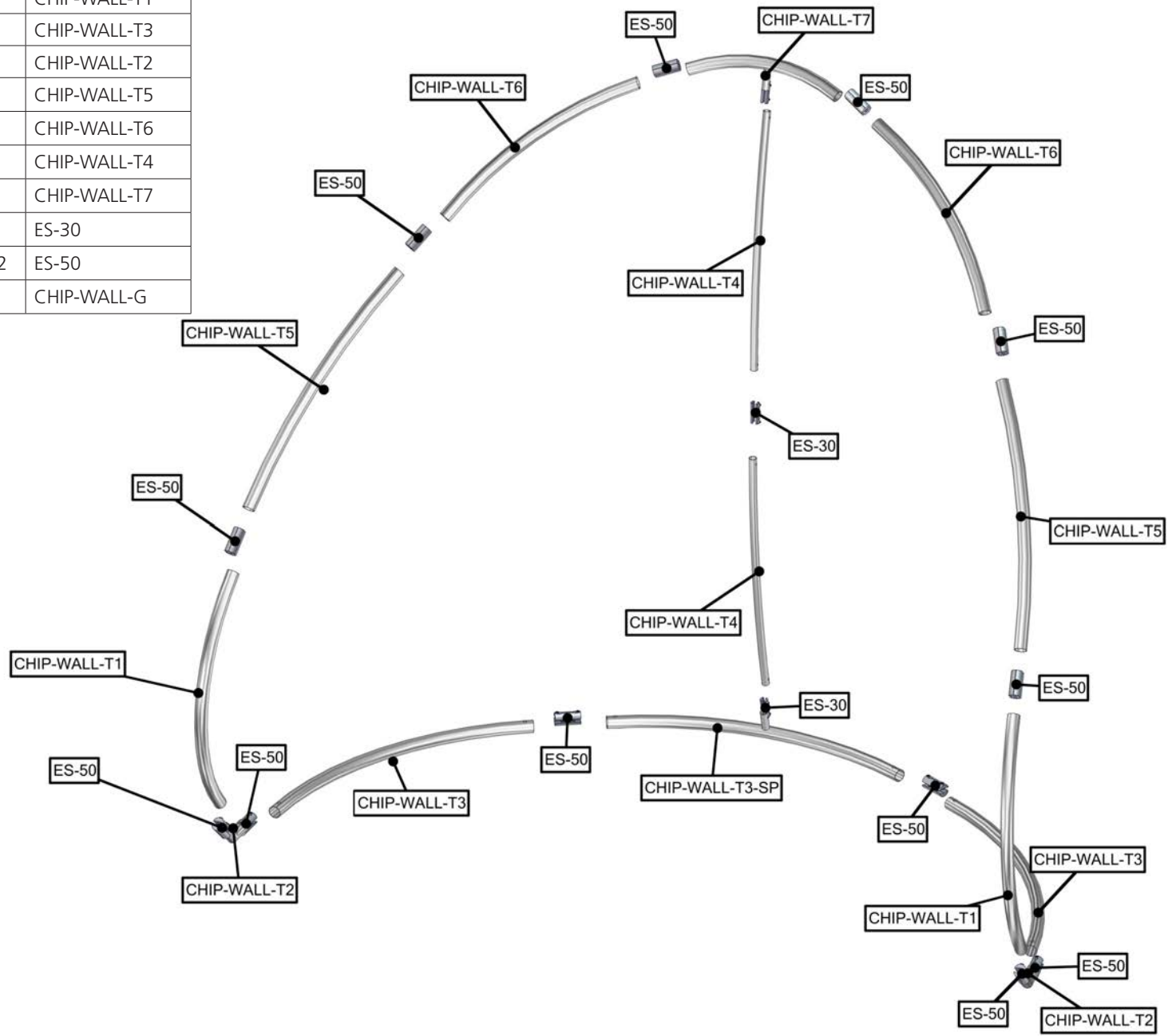

CHIP-WALL FRAME ASSEMBLY:

Assemble unit by laying tubes flat on the floor. Connect the tube rails following the labels by matching number to number.

Slide joiner into tubing so hex screw sits in hole on tubinger. Tighten the hex screw so the joiner separates and tightens against the inside of the tubing, locking the joiner and tubing together.

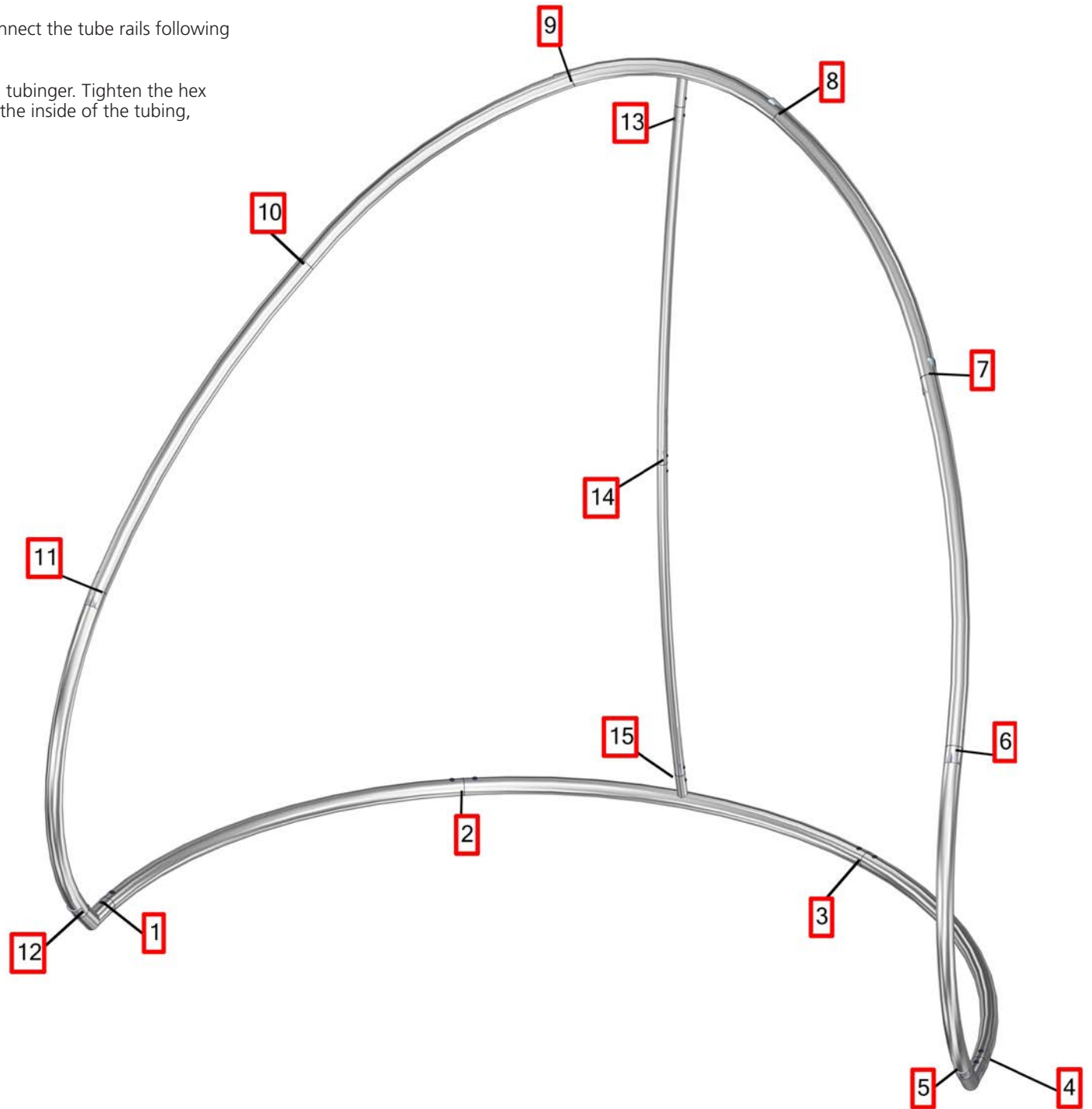

STEP 1: ASSEMBLE FRAME

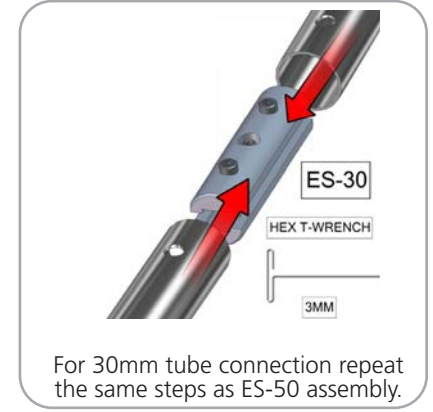
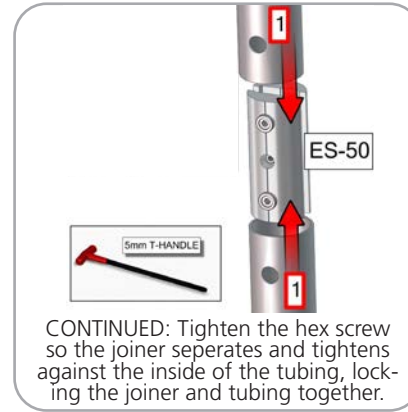
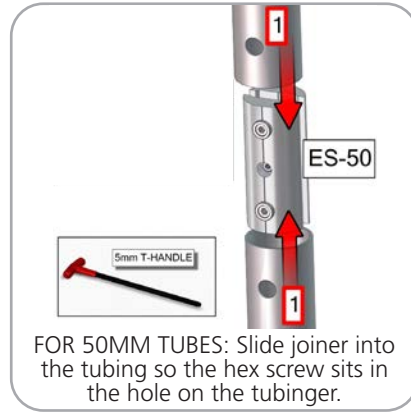
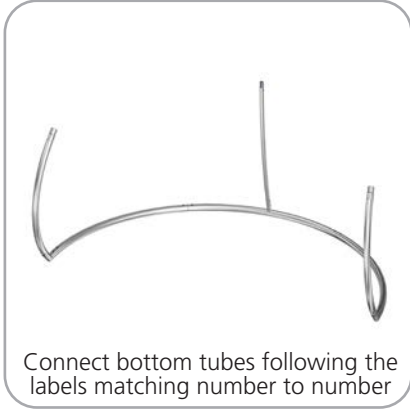

STEP 2: ATTACH GRAPHIC

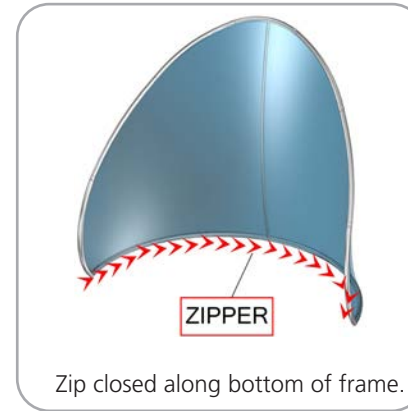
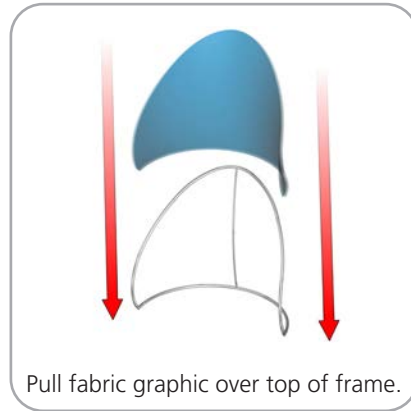
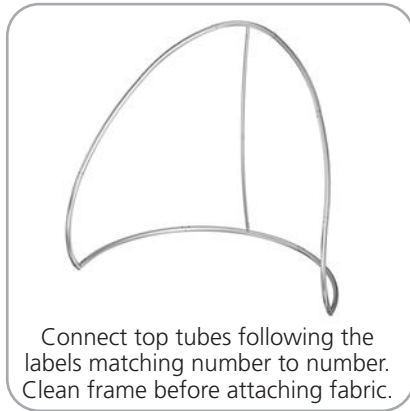

Formulate Counter – Oval

W-05-C

Formulate™ counters couple lightweight hardware with printed stretch silicone edge fabric graphics (SEG) to create funky and functional reception stands. Tables and bases are available in four colored finishes – silver, black, mahogany and natural. Custom sizes also available.



features and benefits:

- Printed stretch silicone edge fabric graphics (SEG) for a custom look
- Counter supports 25 lbs. of weight on center
- Choice of four finishes for table and base
- Kit includes: one frame, two dye-sublimated graphics, table and base, and one wheeled molded OCH2 storage case
- Lifetime hardware warranty against manufacturer defects

dimensions:

Hardware	Graphic
<p>Assembled unit: 47.25" w x 38" h x 23.75" d 1200mm(w) x 970mm(h) x 600mm(d)</p> <p>Approximate kit weight (includes graphic): 53 lbs / 24 kgs</p>	<p>Total visual area: 57.629" w x 35.424" h</p> <p>Refer to related graphic template for more information.</p> <p>Visit: www.exhibitors-handbook.com/graphic-templates</p>
<p>Shipping</p> <p>Shipping dimensions: One OCH2 case: 50" l x 30" w x 15" h</p> <p>Approximate shipping weight: (kit and case) 85 lbs / 38.55 kgs</p>	

additional information:

Graphic material:
Dye-sublimated fabric

Top/Base finishes:



silver black mahogany natural



www.display-setup-animations.com

We are continually improving and modifying our product range and reserve the right to vary the specifications without prior notice. All dimensions and weights quoted are approximate and we accept no responsibility for variance. E&OE. See Graphic Templates for graphic bleed specifications.

Parts Included		
Part Label	Qty	Part Code
5/16-18 WING NUT	x12	5-16-18 WING NUT
5/16-18 X 1.25" STEEL STUD	x6	5_16_18 X 1.25 STUD
5/16-18 X 2" STEEL STUD	x6	5_16_18 X 2 STUD
2.5" PLASTIC GROMMET	x1	2.5IN-GR-CAP
900MM LENGTH OF TRILOK TRUSS	x2	TRI30-COUNTER
OVAL BASE WITH FC RING	x1	W-05-C-BASE
OVAL FABRIC GRAPHIC	x1	W-05-C-G
OVAL TOP	x1	W-05-C-TOP

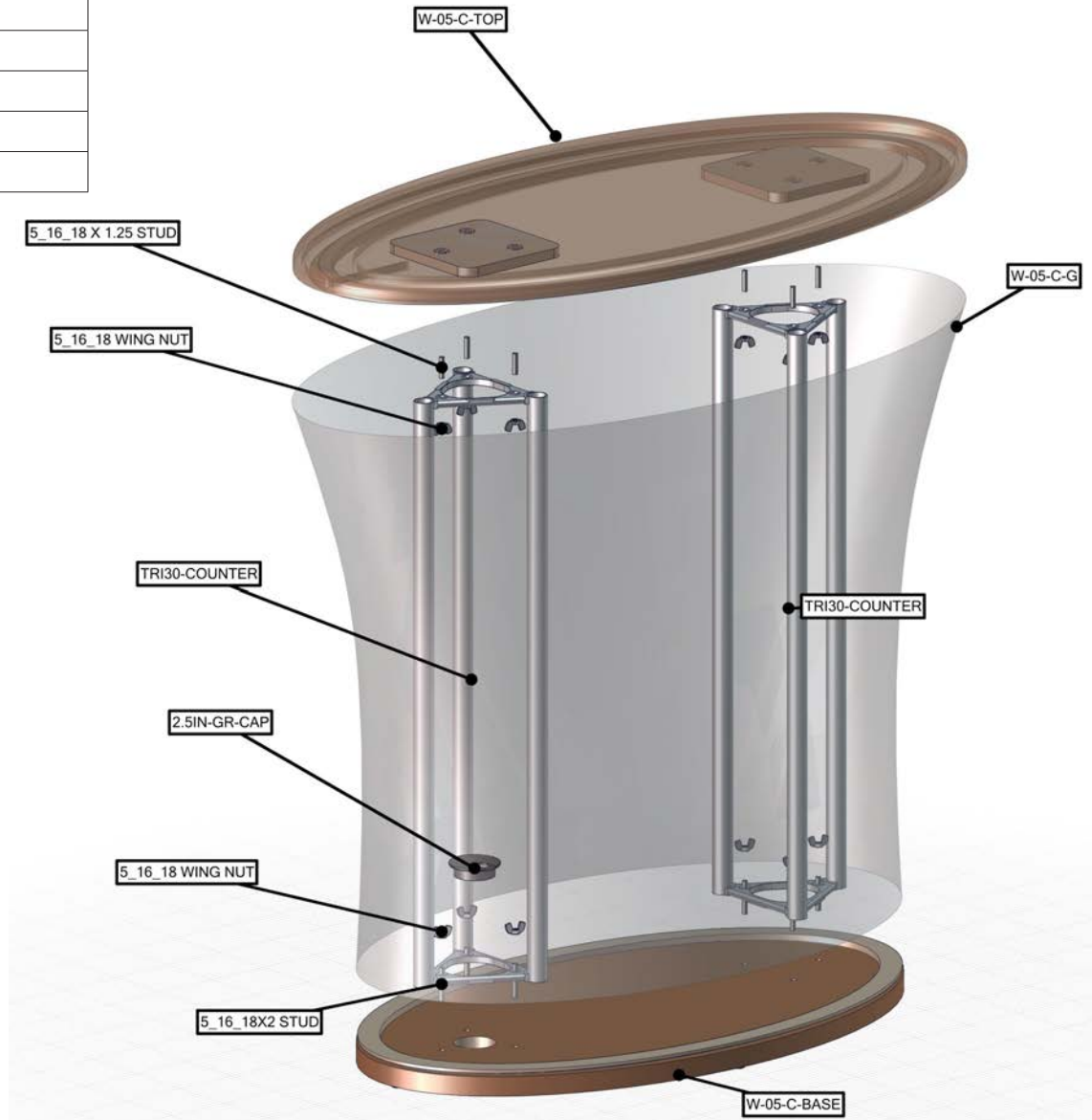
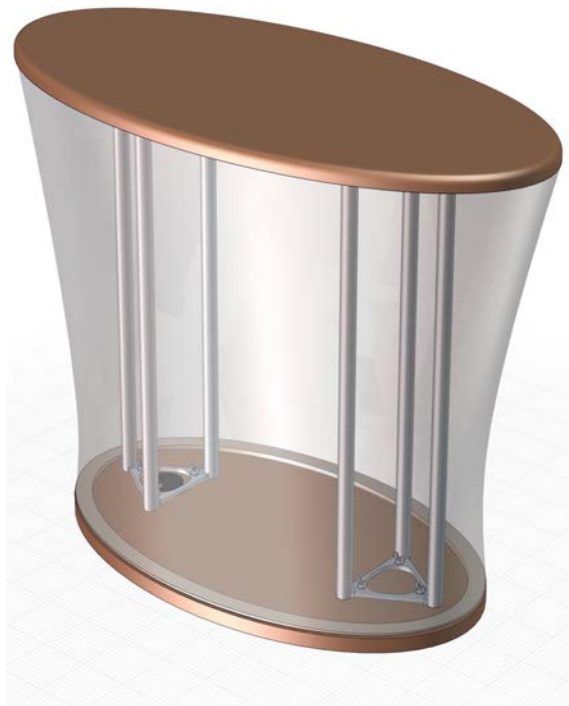

STEP 1: ATTACH BASE

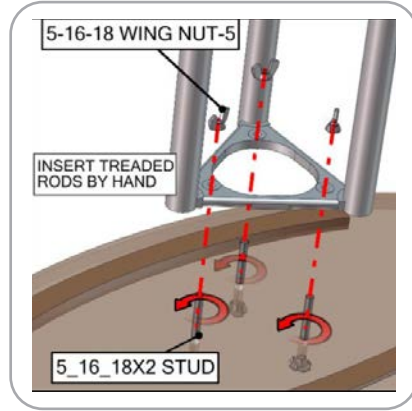
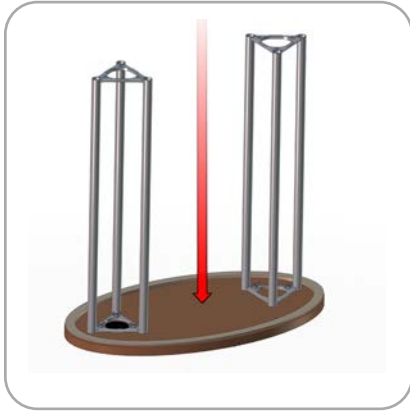

STEP 2: ATTACH GRAPHIC

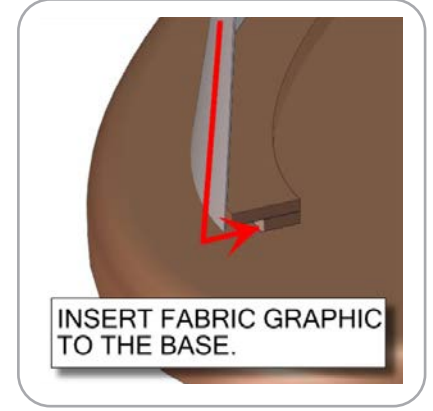
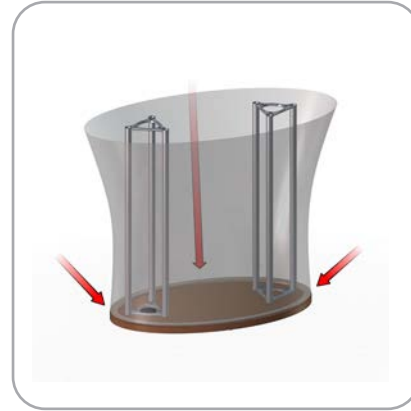

STEP 3: ATTACH TOP

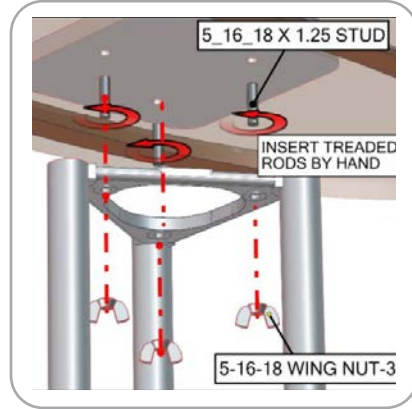
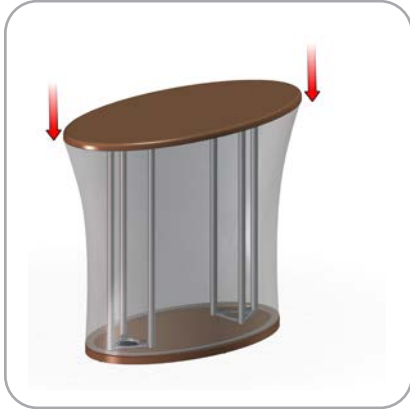

STEP 4: ATTACH GRAPHIC

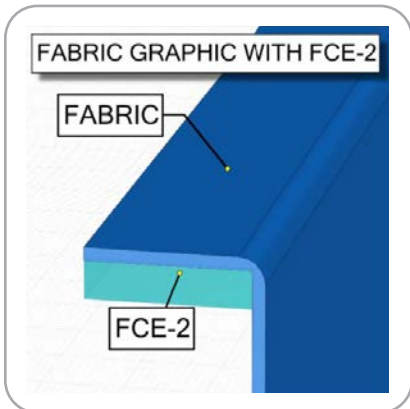
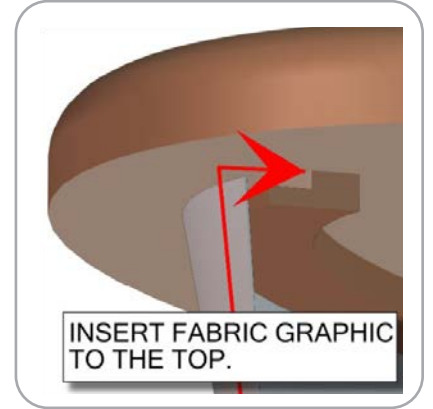

FUSION 20 X 20 KIT CFAB-K-06

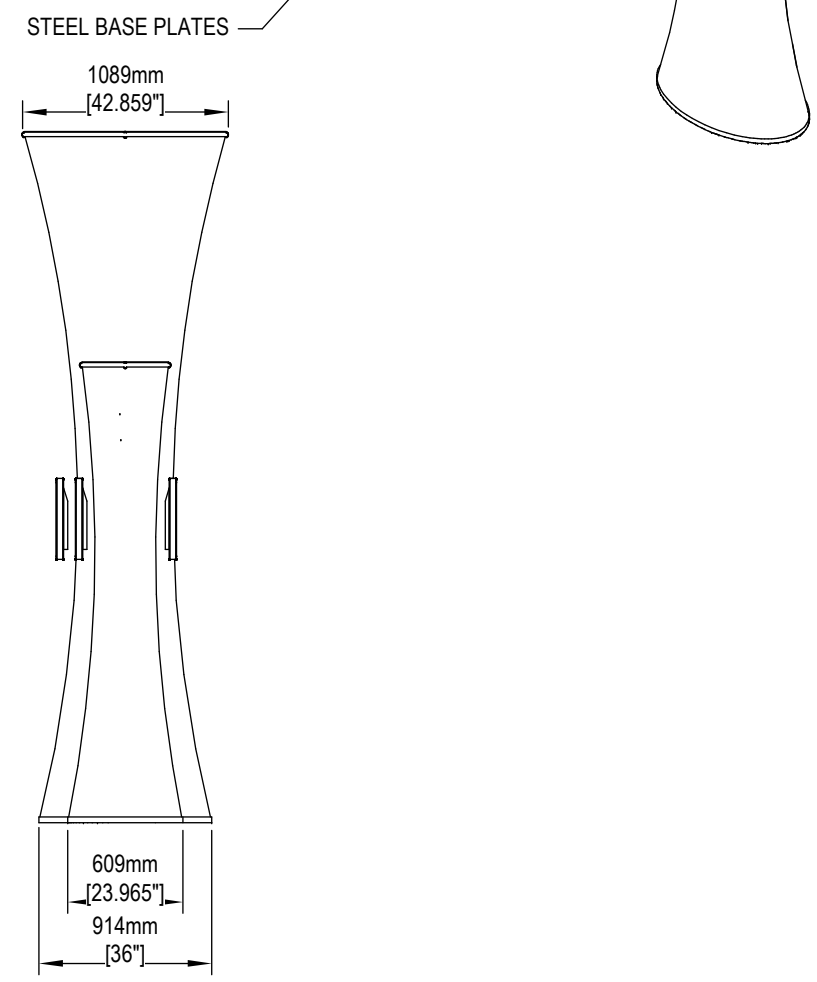
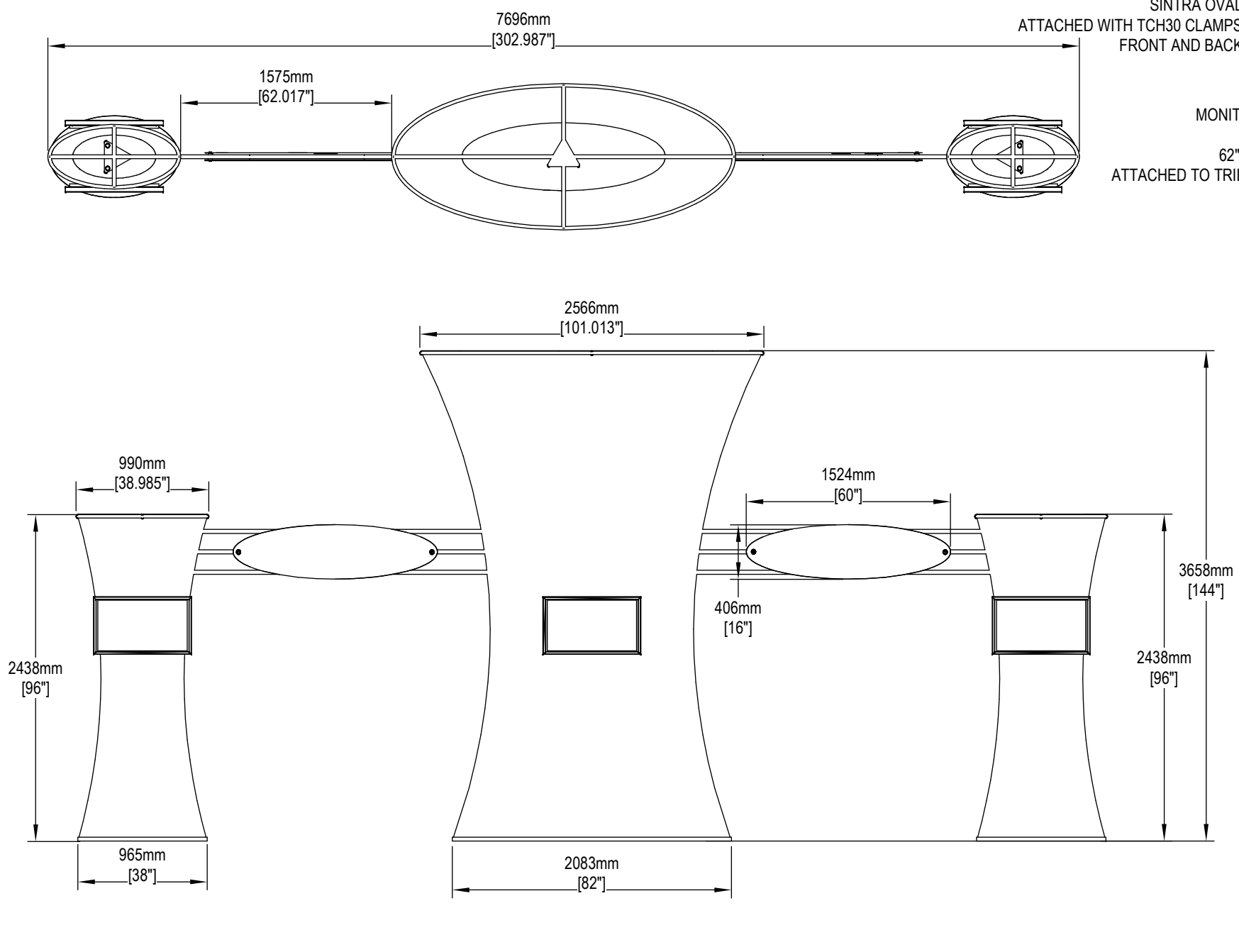
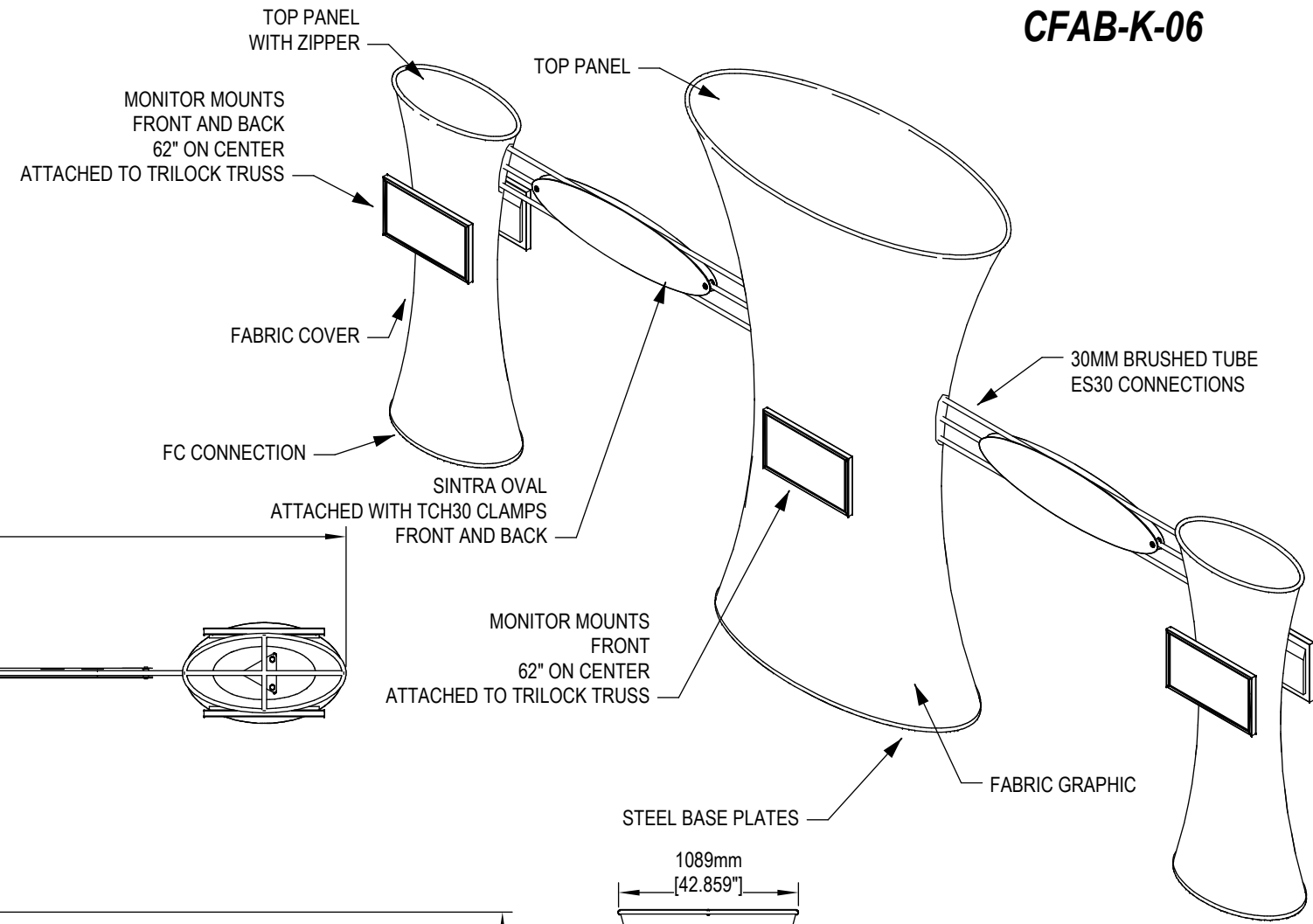

Order #:	
Client	
Dist.	
Dept.	
Man.	
Set up	
Preview	
Ship	
Item	Qty
Packing	
Graphics Size	
Project Manager	
File Name	
Detailer	Date
Description	
MAX. ALLOWABLE TOLERANCES PER 2400mm FABRICATION = ±4mm	
CHECKED BY: _____ DATE: _____	