

Hybrid Pro 10FT Modular Backwall Kit 24

HP-K-24

Hybrid Pro™ Modular Kit 24 is a stylish and functional modular exhibit that offers a locked storage closet, ample real estate for branding, as well a display counter and multi-media display. This exhibit kit has it all! Push-fit SEG fabric graphics are coupled with extrusion frames for a seamless, sleek look.



features and benefits:

- Silver aluminum extrusion frames
- SEG push-fit fabric graphics
- Locked storage closet with fabric graphics
- Backwall counter color options: Silver, Black, Mahogany, Natural
- Medium monitor bracket holds 32-55" LCD*, max weight: 50 lbs
- Ships freight in a roto molded case
- Lifetime hardware warranty against manufacturer defects

dimensions:

Hardware

Assembled unit:
114.76" w x 95.45" h x 70.2" d
2915mm(w) x 2425mm(h) x 1784mm(d)

Approximate weight:
249 lbs / 113 kg

Graphic

Refer to related graphic template for more information.

Visit:
<https://www.theexhibitorshandbook.com/download-graphic-templates>

Shipping

Packing case(s):
3 OCH2

Shipping dimensions:

OCH2:
52" l x 29" h x 15" d
1321mm(l) x 737mm(h) x 381mm(d)

Approximate total shipping weight:
339 lbs / 154 kg

additional information:

Graphic material:

Dye-sublimation SEG push-fit fabric

When included in a larger kit, a different packaging solution will be listed to accommodate all contents of the kit. Individual packaging no longer provided.

Tabletop Colors:



2 person assembly recommended:



This product may include the following materials for recycle:
aluminum, select wood, fabric, cardboard, paper, steel, and plastics.

We are continually improving and modifying our product range and reserve the right to vary the specifications without prior notice. All dimensions and weights quoted are approximate and we accept no responsibility for variance. E&OE. See Graphic Templates for graphic bleed specifications.

Included In Your Kit

Tools, Components, & Connectors



HEX KEY SET x1

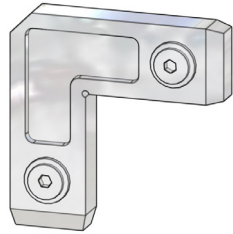

CB9 x4

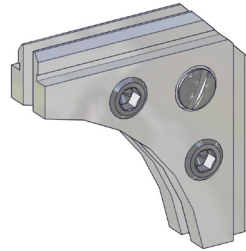

CBE-50 x12

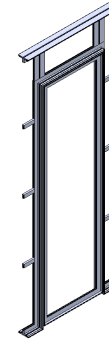

F-FCDOOR-900-LEFT x1



AF16-300-MCB4-MBC4-SIDE x2

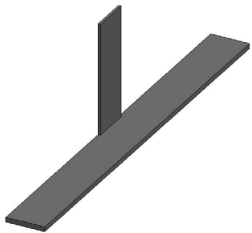

SW-FOOT-500 x2



PH1-1155-L-L1 x2

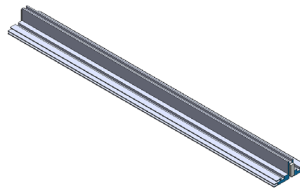

PHFC4-900-L1-MCB9 x4

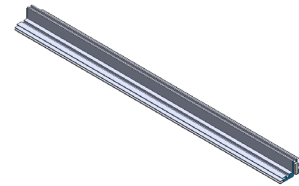

PHFC4-900-L-L x6



PHFC4-1200-L1-MCB9 x4

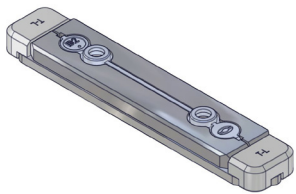

IB2 x5

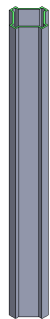

PM4DSC-600 x4



PMFC4-90-1193-A315 x8

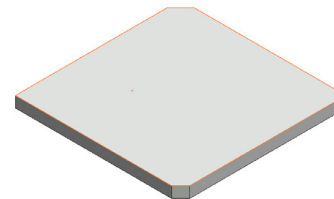

PMFC4-90-CAP x8

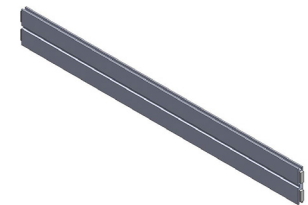

PS2-900-L-L x1

Included In Your Kit

Tools, Components, & Connectors











EXT-M-MB x1

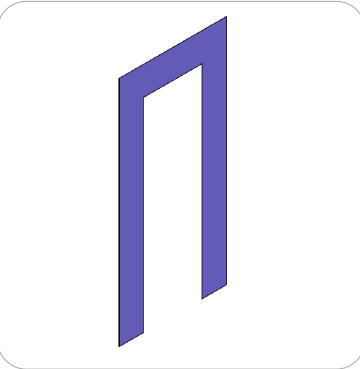
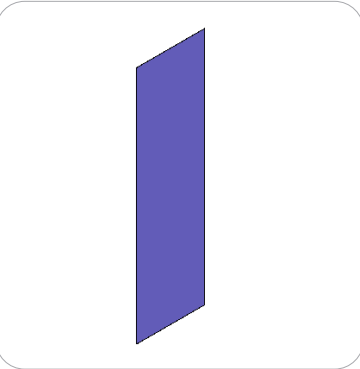
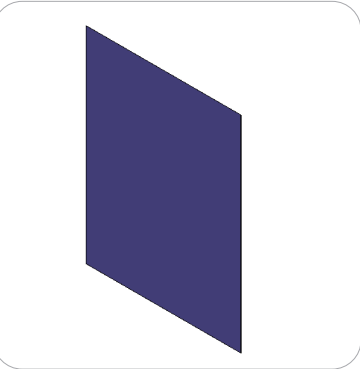

VFC-04 x1

Included In Your Kit

Graphics

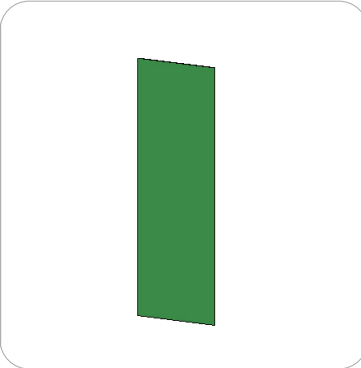
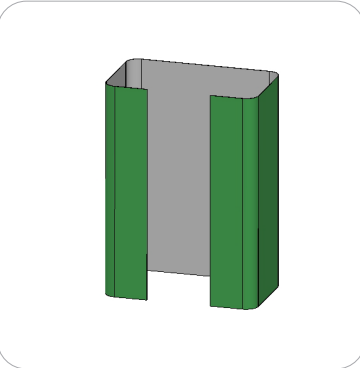
				
HP-24-A-G x1	HP-24-B-G x1	HP-24-C-G x1	HP-24-D-G x1	HP-24-E-G x1
				
HP-24-H-G x1	HP-24-F-G x1	HP-24-G-G x1	HP-24-K-G x1	HP-24-I-G x1
				
HP-24-J-G 1	VFC-04-B-G x1	VFC-04-A-G x1		

Exploded Diagram

HP-K-24
Complete Setup

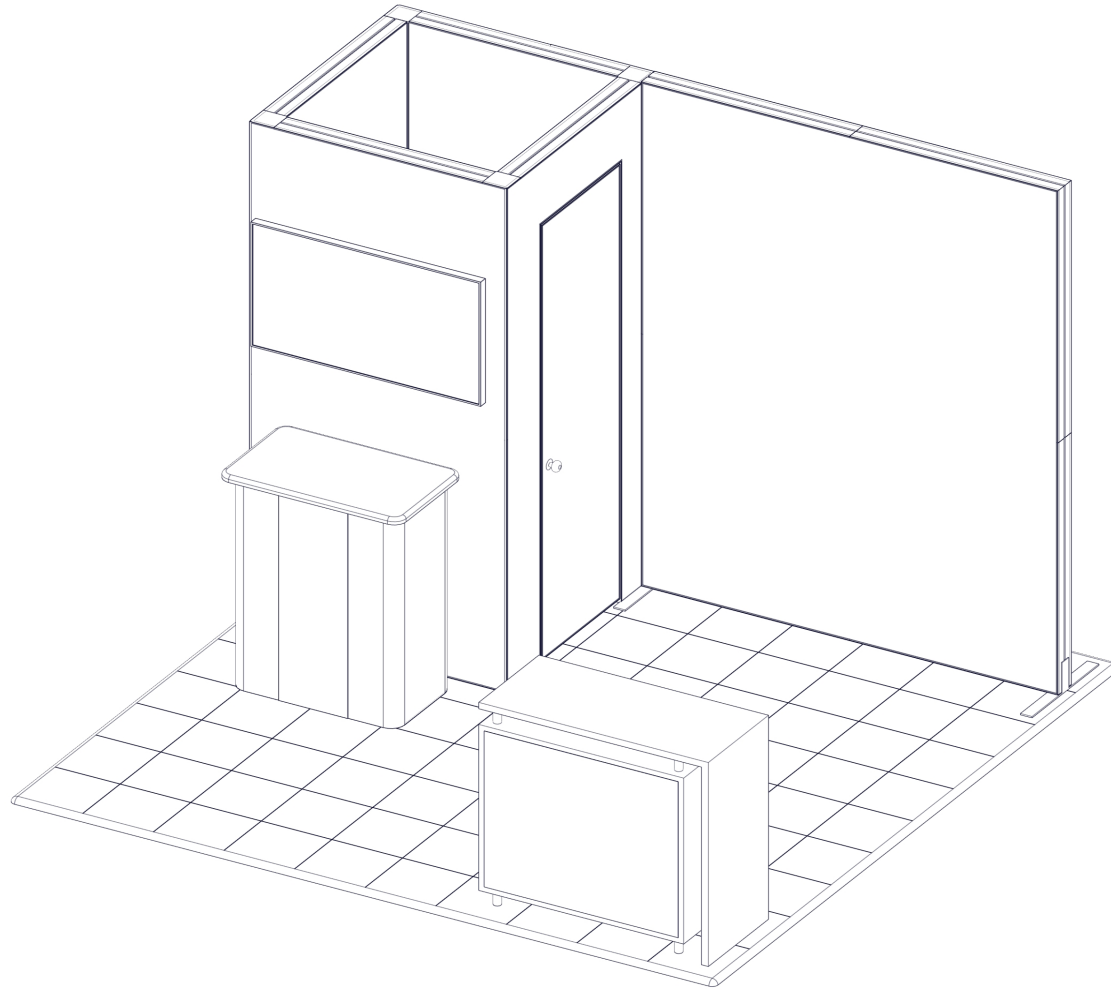

Exploded Diagram

HP-K-24

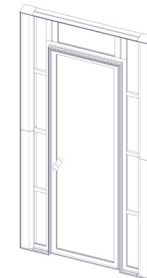
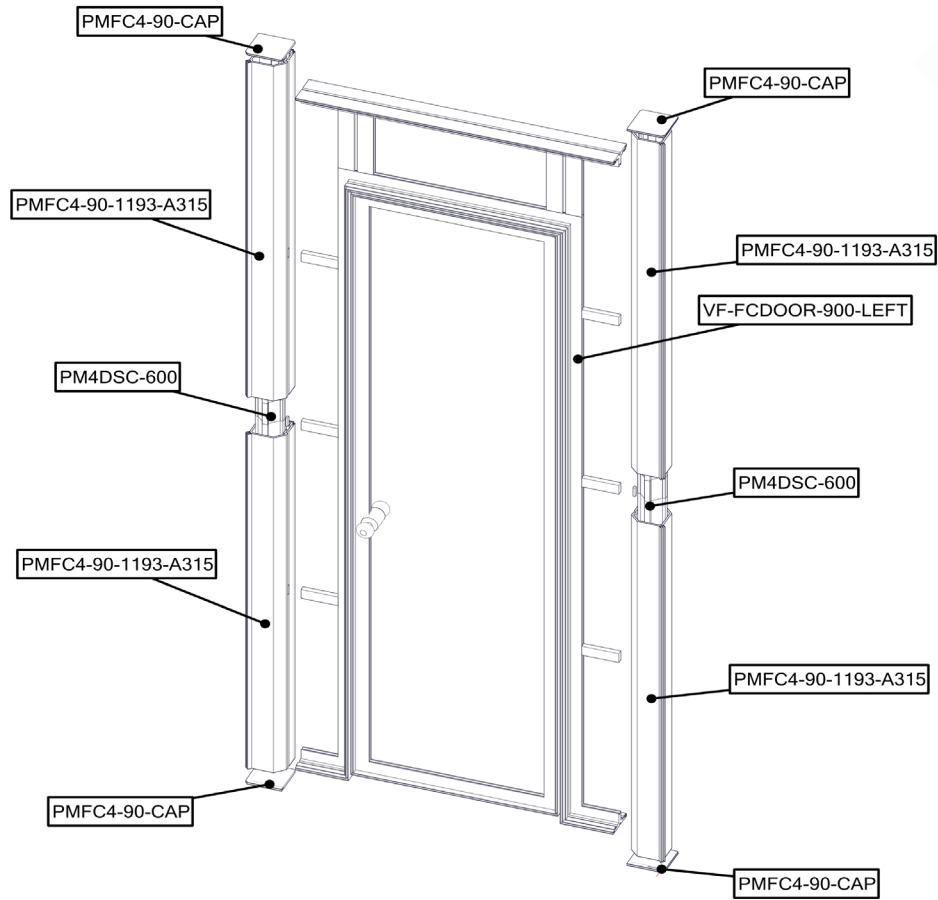

-Assemble Door & First Wall

Exploded Diagram

HP-K-24

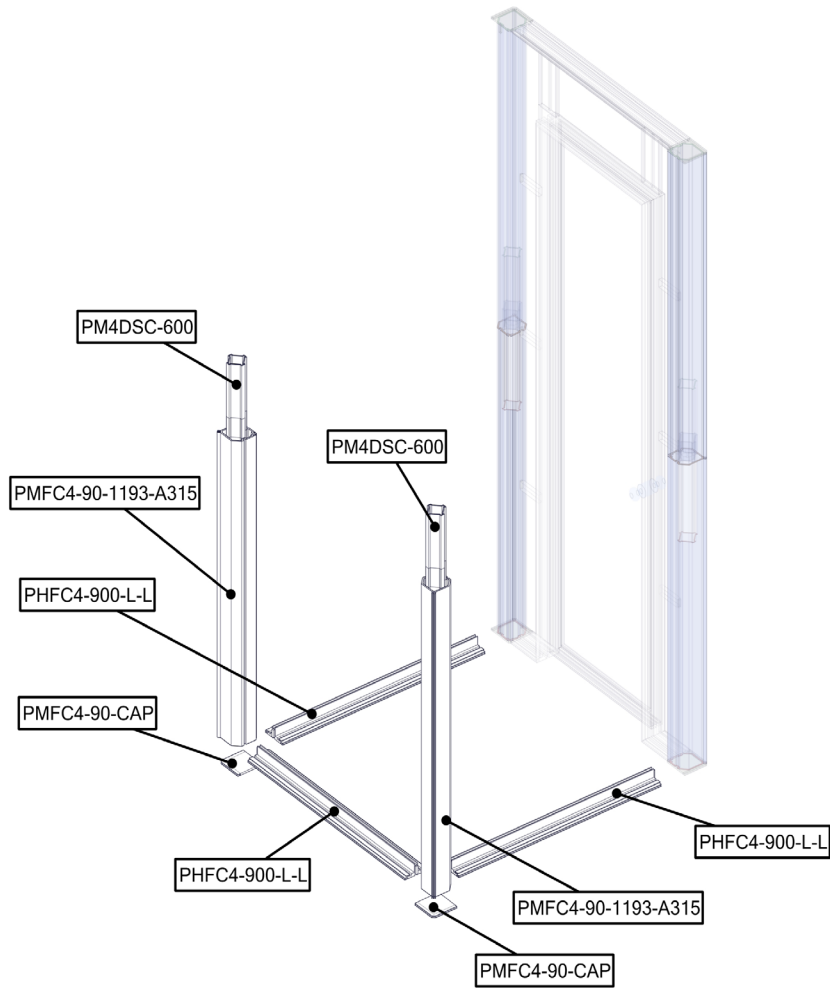

-Assemble Bottom of Closet

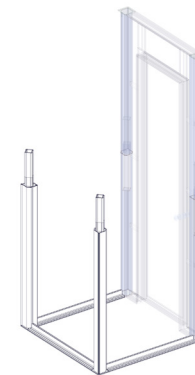
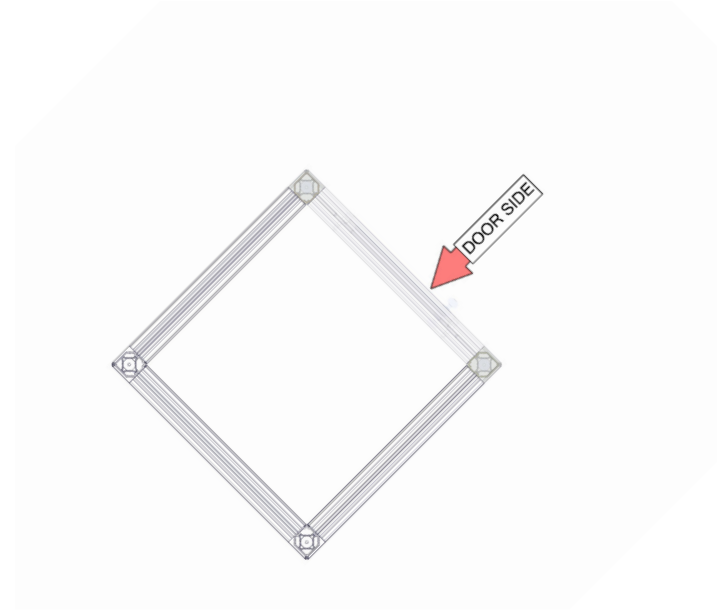

Exploded Diagram

HP-K-24

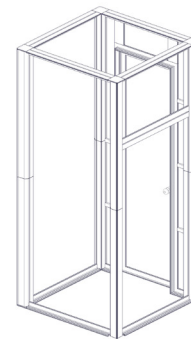
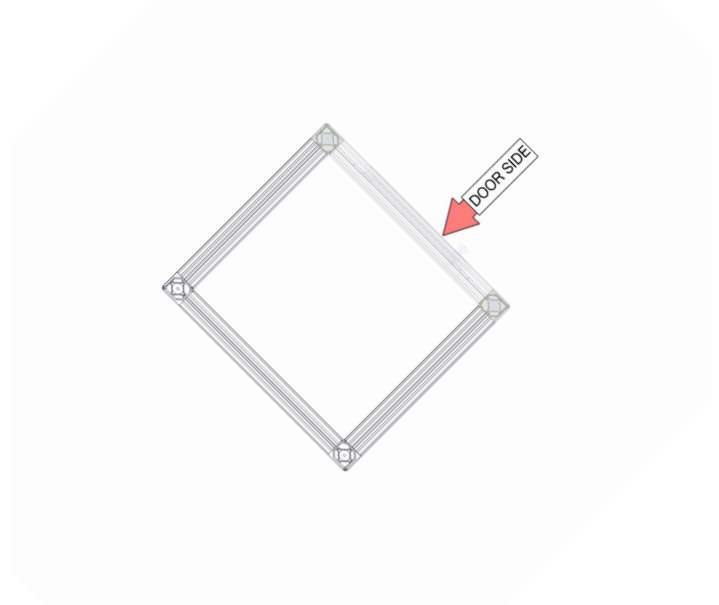
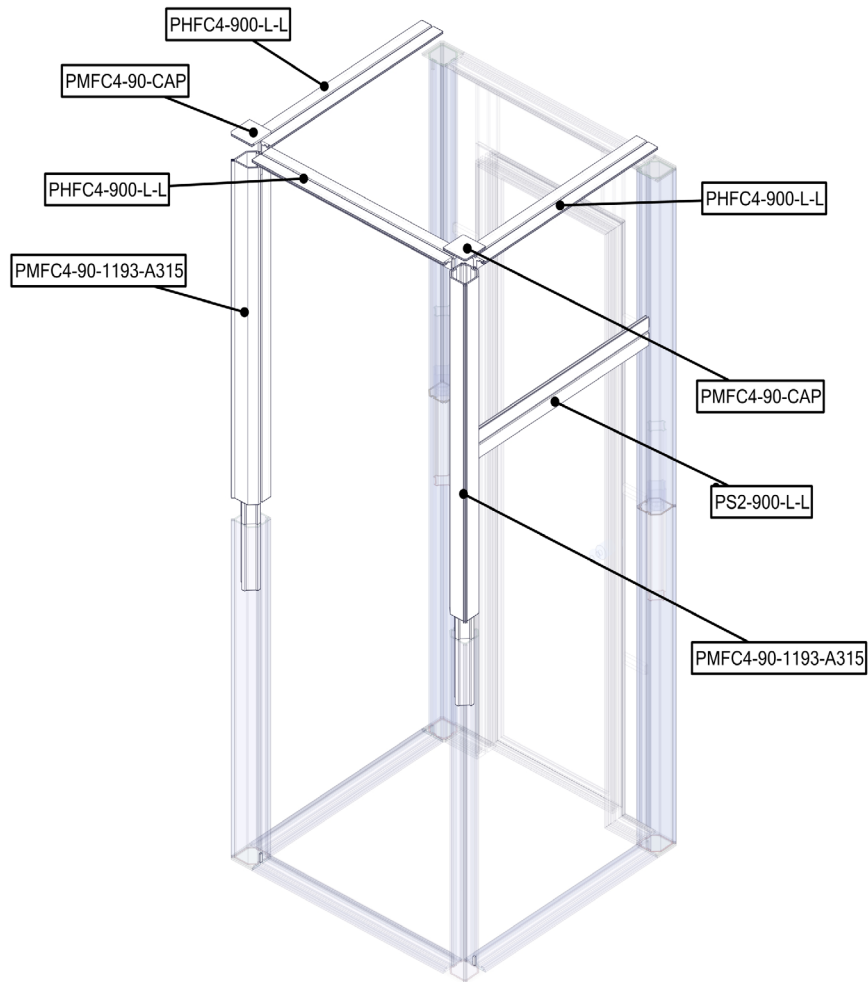

-Assemble Top of Closet

Exploded Diagram

HP-K-24

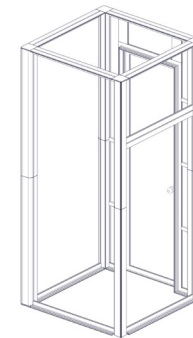
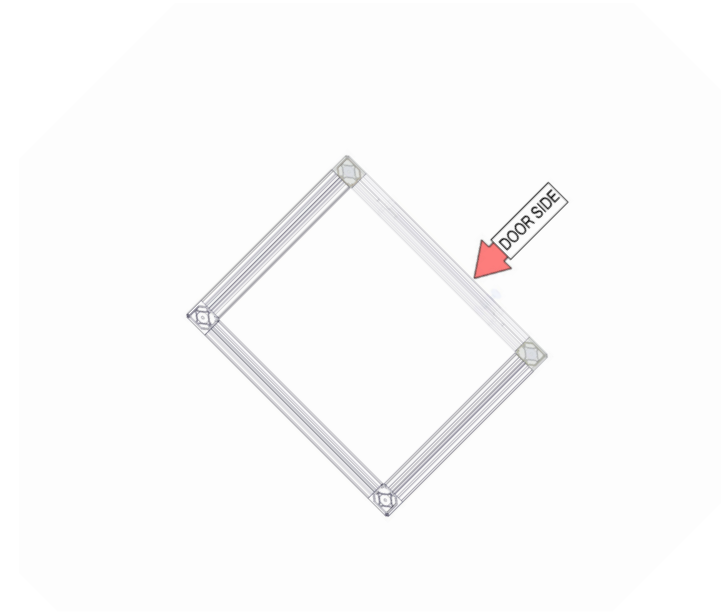
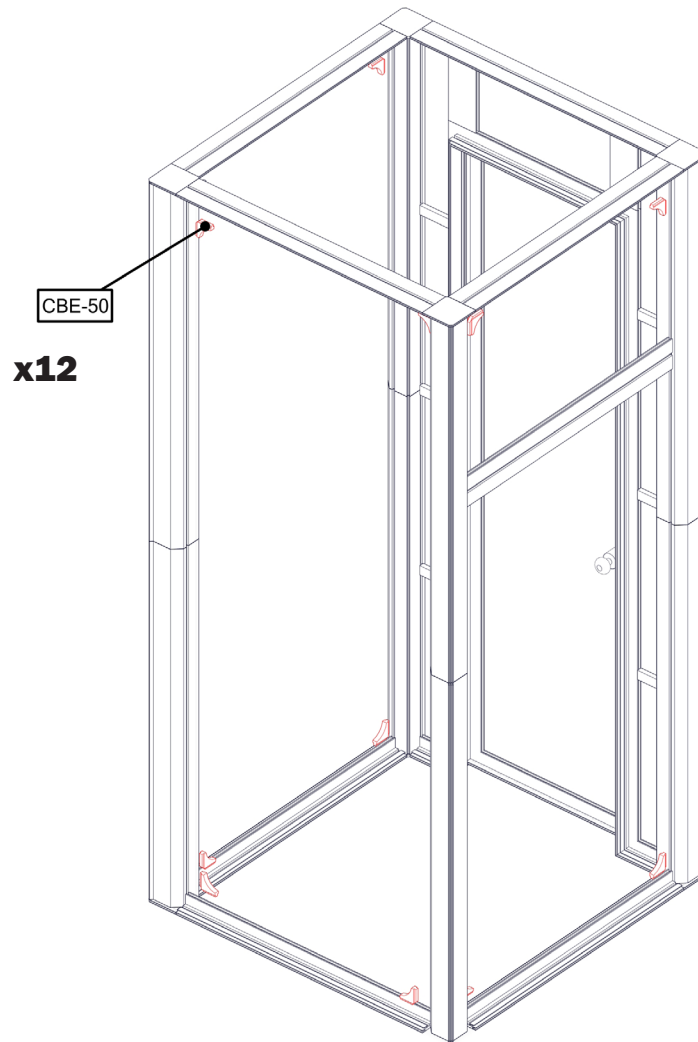

-Attach CBE-50 for Support x12

Exploded Diagram

HP-K-24

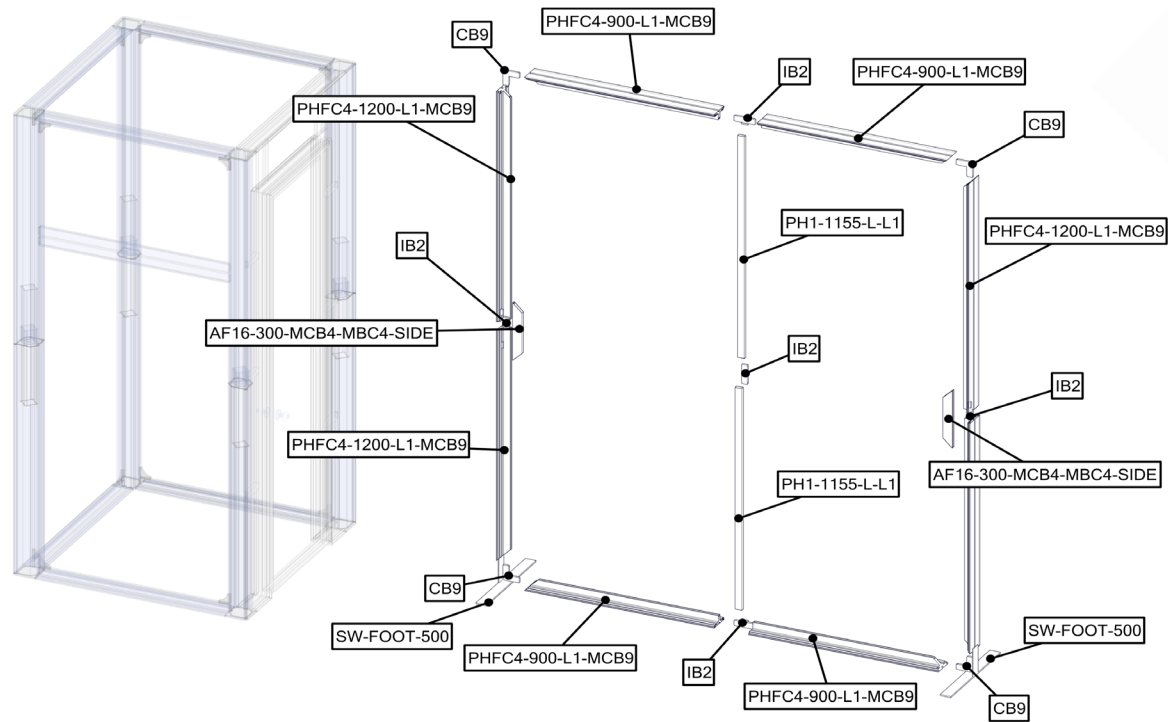

-Assemble Vector Frame

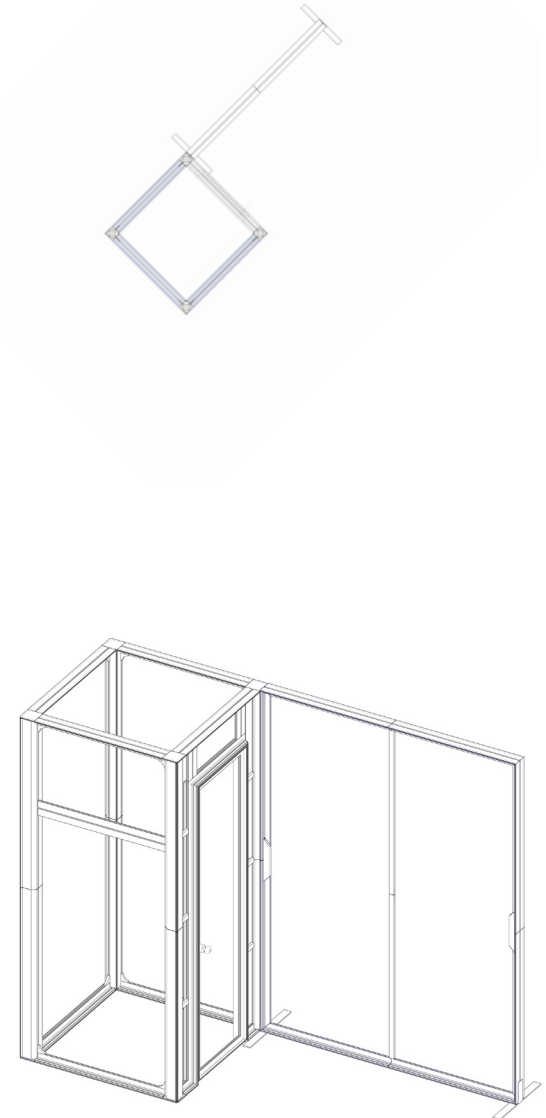

Exploded Diagram

HP-K-24
SECTIONAL LAYOUT

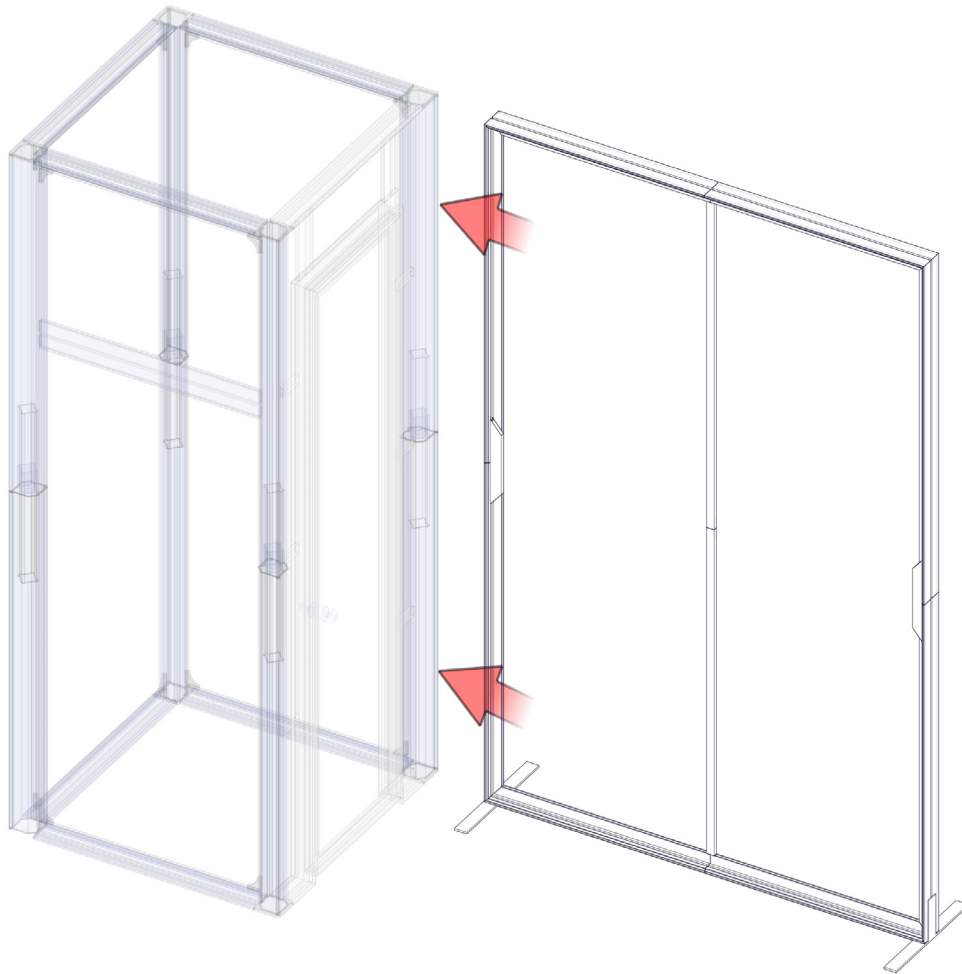

-Attach closet & Vector Frame

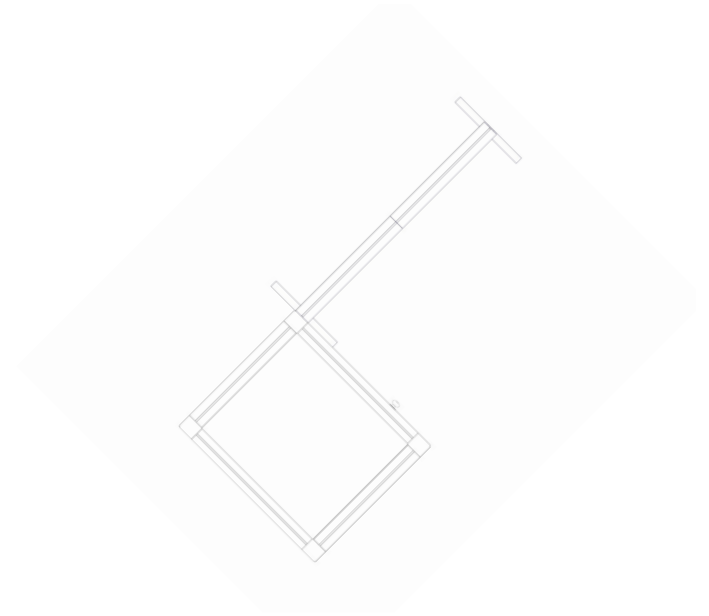

Exploded Diagram

HP-K-24

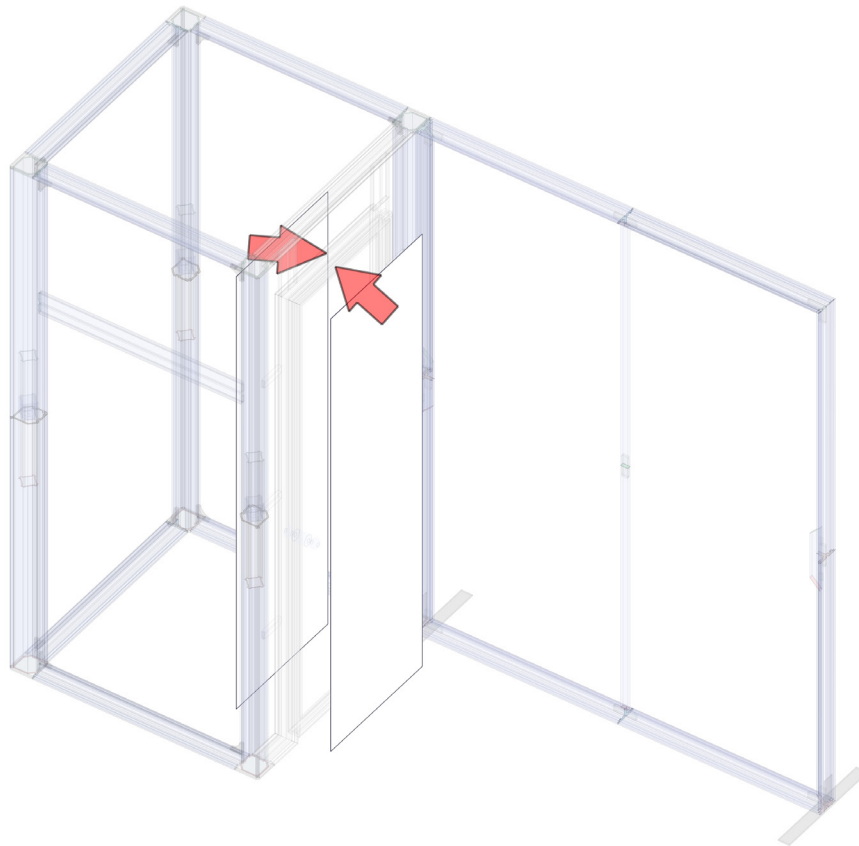

-Attach Door Graphics

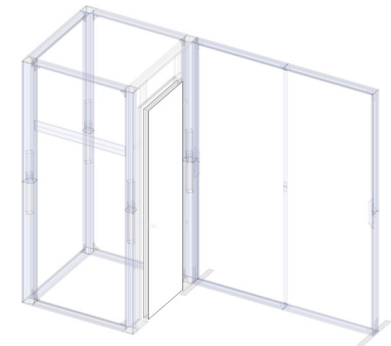
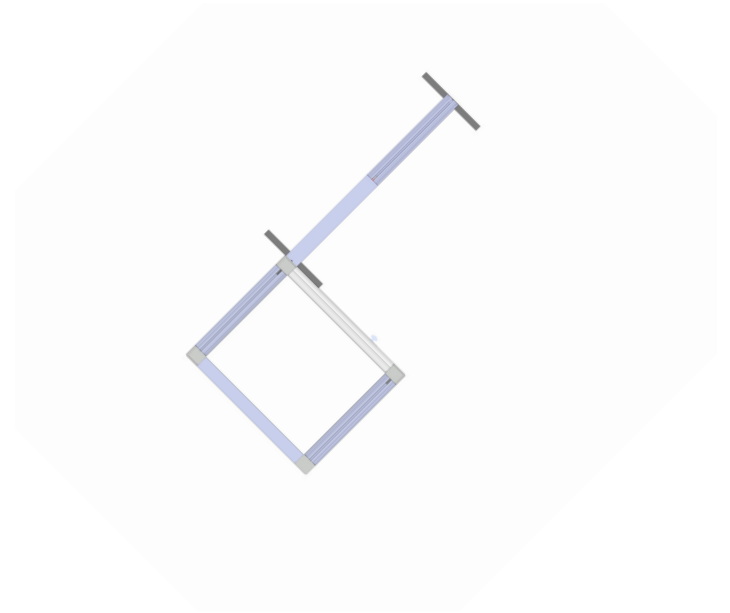

Exploded Diagram

HP-K-24

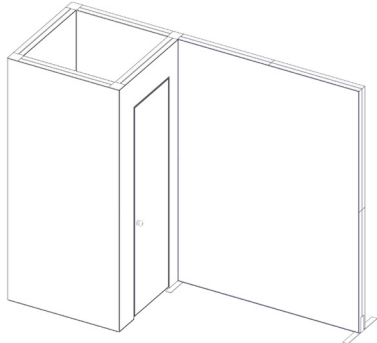
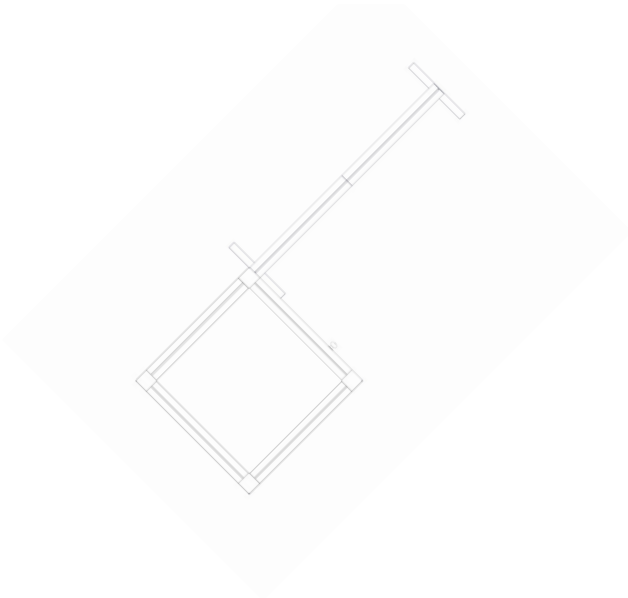
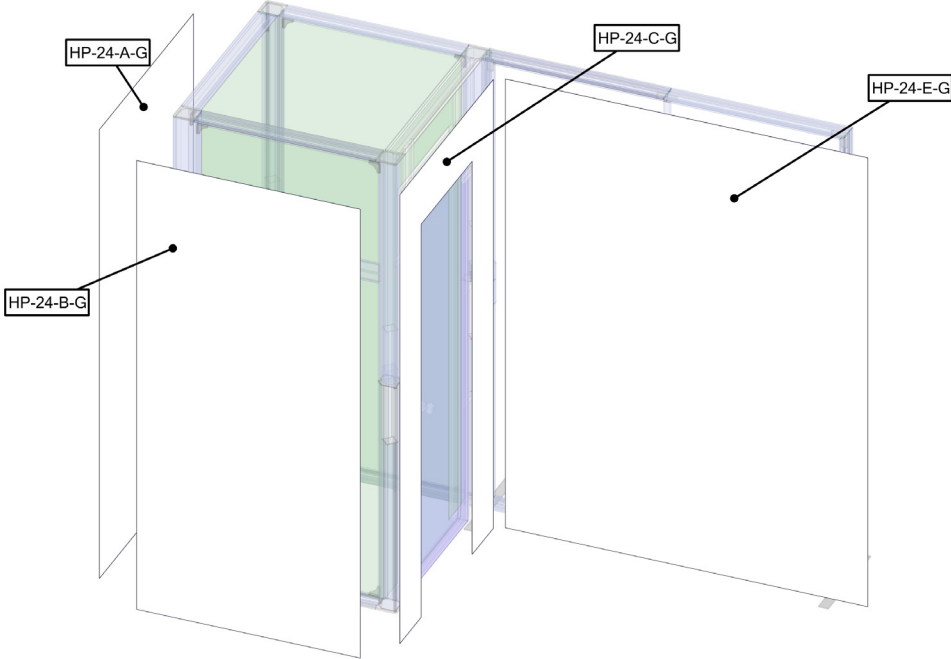

-Attach Outside Graphics

Exploded Diagram

HP-K-24

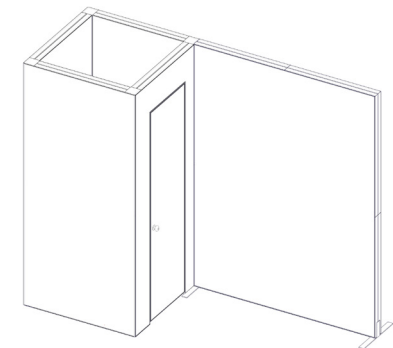
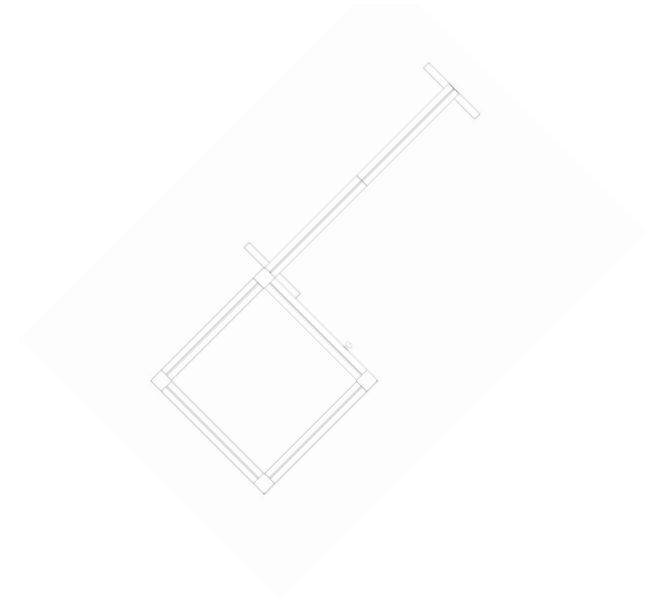
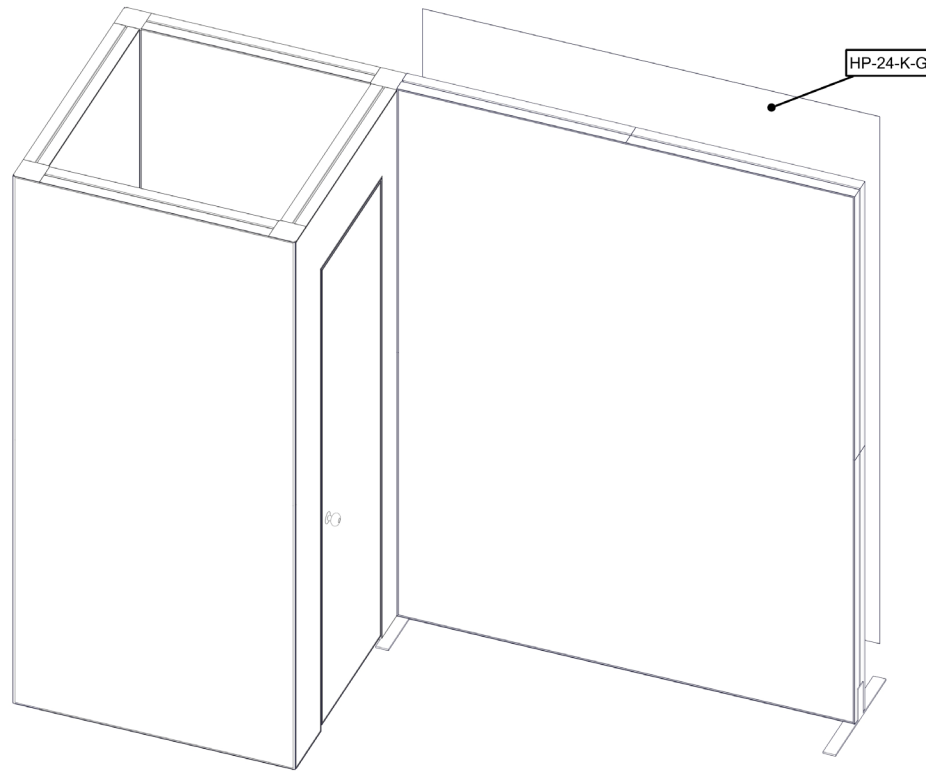

-Attach Rear Liner

Exploded Diagram

HP-K-24

**See attach PDF for detailed
instructions on assembly of
VFC-04 counter.**

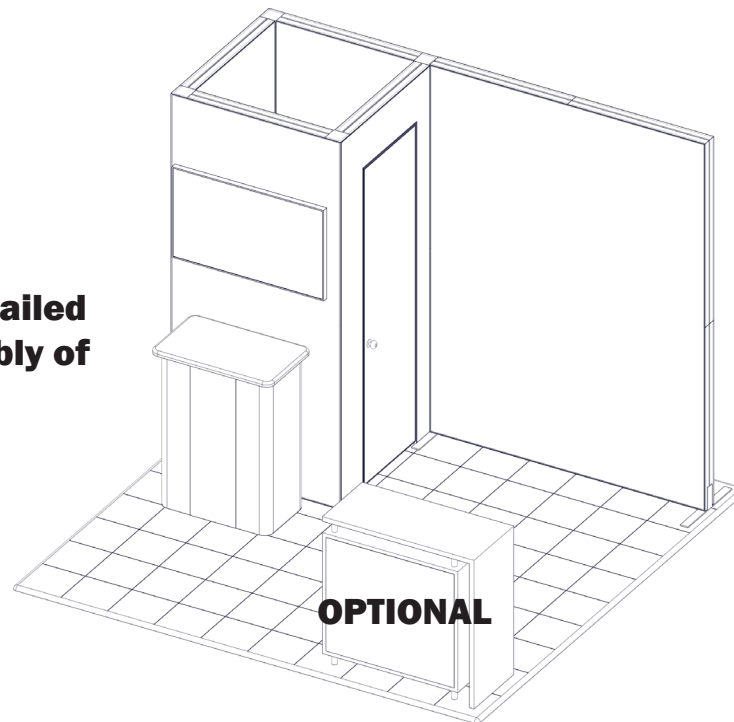

Suggested Kit Layout

HP-K-24
SECTIONAL LAYOUT

VECTOR FRAME 1.1

STORAGE CLOSET 1.2

VFC-04 1.3

OPTIONAL COUNTER

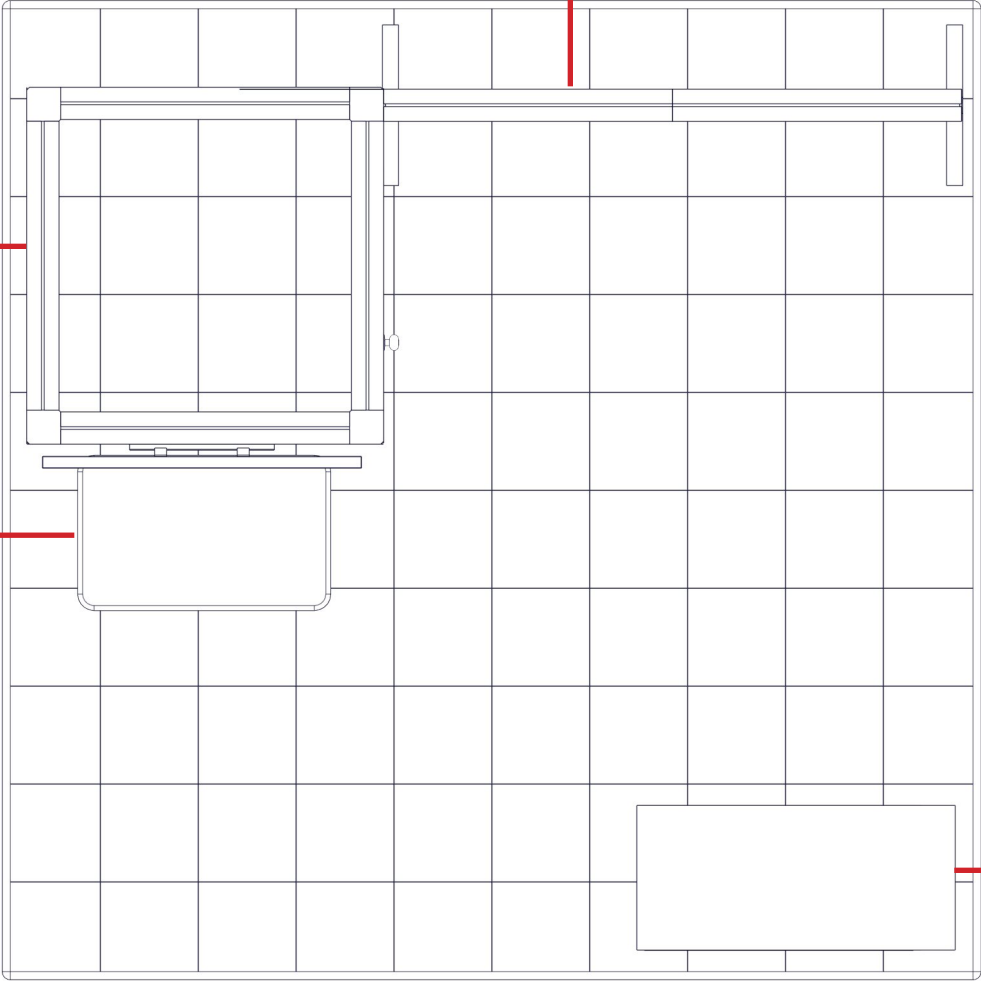

Kit Assembly

Step by Step

Step 1.

Gather the components to build the door & wall. Use the Exploded View and the Labeling Diagram for part labels.

Reference Connection Method(s) 8, 10, 11, & 12 for more details.

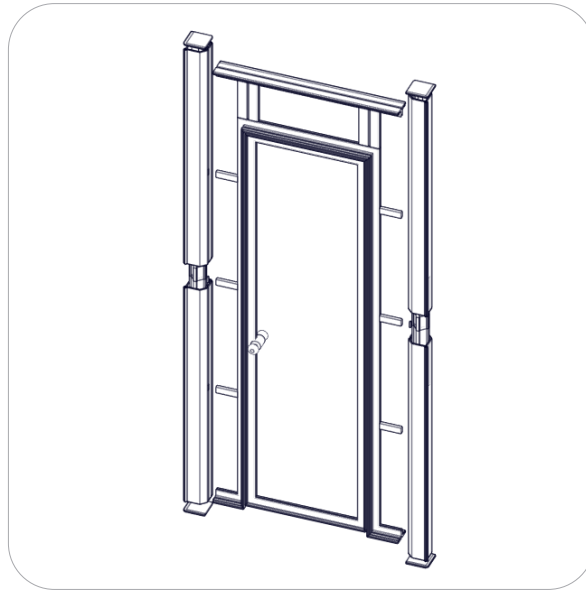
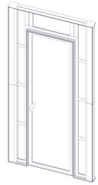

Step 2.

Gather the components to build the bottom of storage closet. Use the Exploded View and the Labeling Diagram for part labels.

Reference Connection Method(s) 8, 10, & 11 for more details.

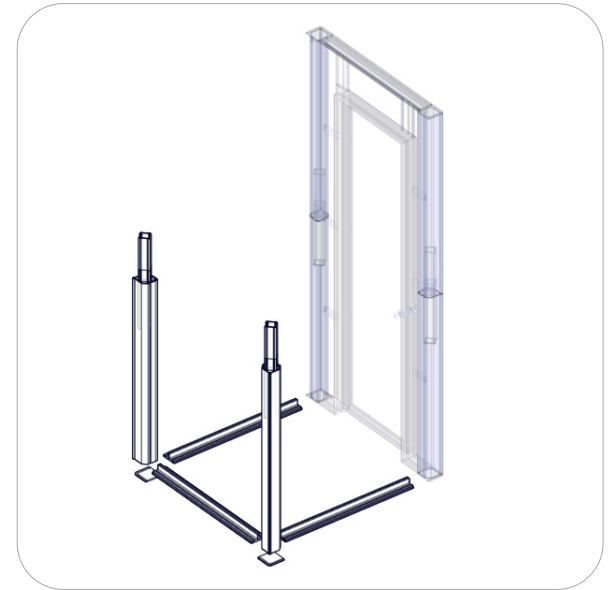

Step 3.

Gather the components to build the storage closet top & add PS2 for mount placement. Use the Exploded View and the Labeling Diagram for part labels.

Reference Connection Method(s) 8, 10, 11, & 13 for more details.

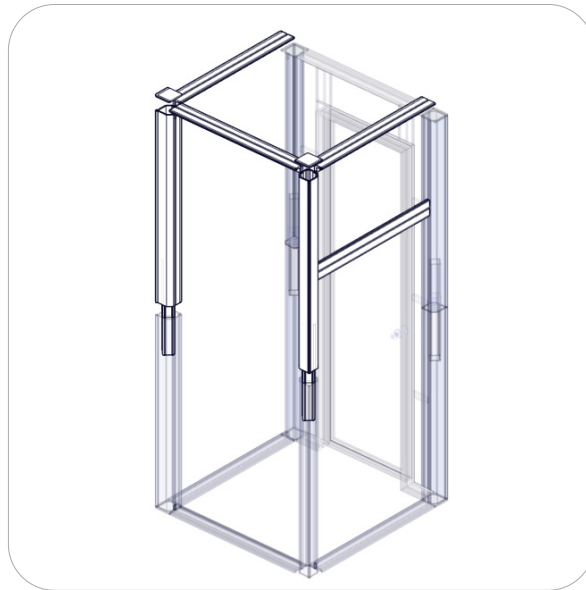
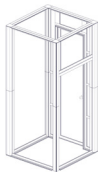

Step 4.

Gather the components to add CBE-50 for support. Use the Exploded View and the Labeling Diagram for part labels.

Reference Connection Method(s) 5 for more details.

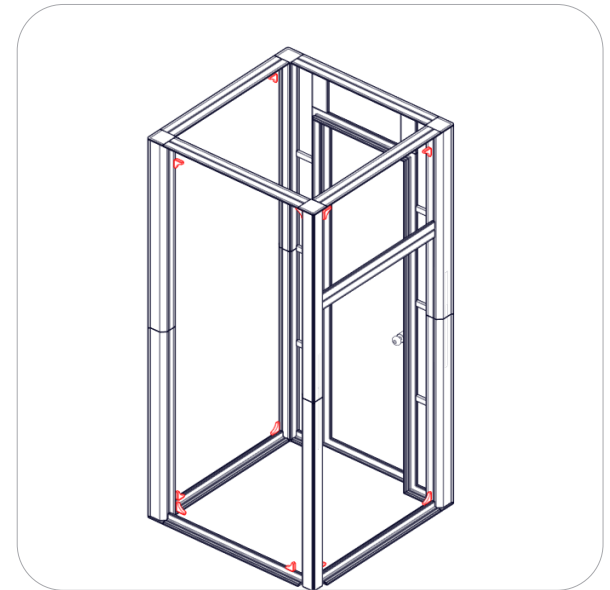
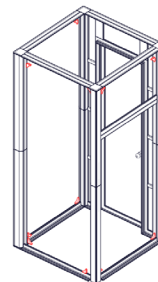

Kit Assembly

Step by Step

Step 5.

Assemble Vector frame together. Use the Exploded View and the Labeling Diagram for part labels.

Reference Connection Method(s) 1, 2, 3, 4, & 7 for more details.

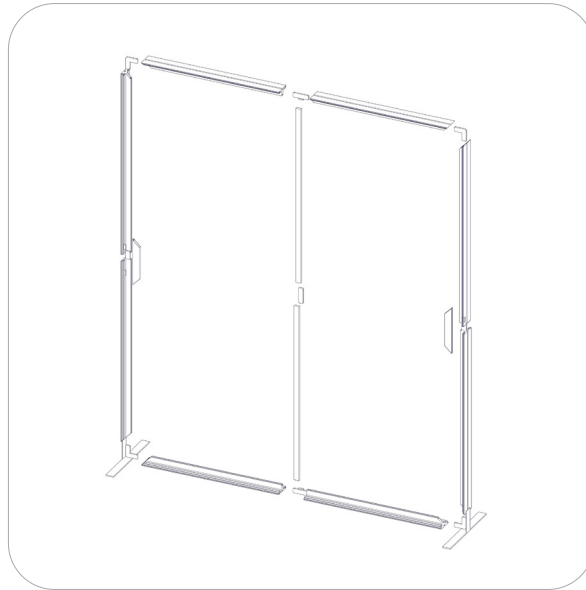

Step 6.

Lock storage closet & Vector frame together using cam locks. Use the Exploded View and the Labeling Diagram for part labels.

Reference Connection Method(s) 15 for more details.

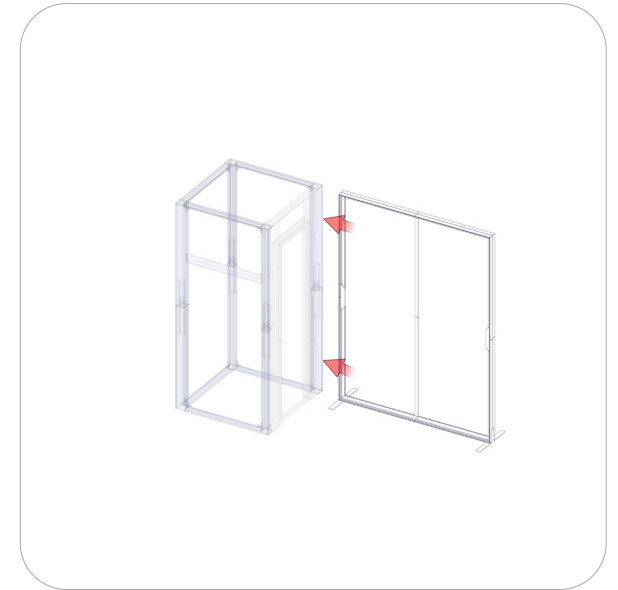

Step 7.

Attach graphics to inside & outside vector door. Use the Exploded View and the Labeling Diagram for part labels.

Reference Connection Method(s) 9 for more details.

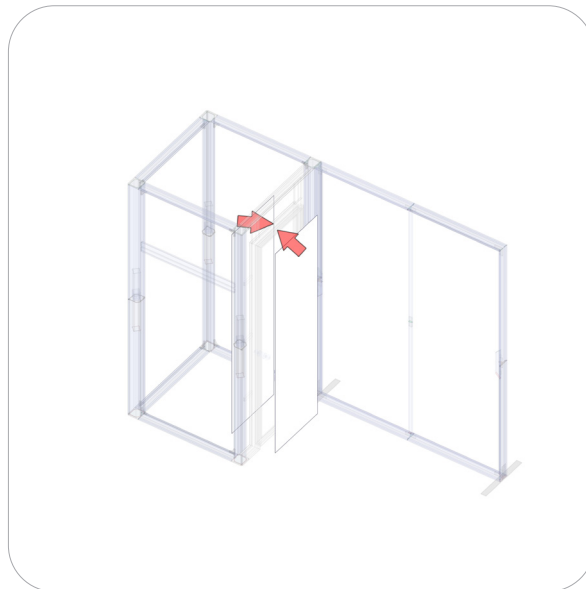
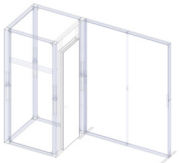

Step 8.

Attach inner graphics of storage closet. Use the Exploded View and the Labeling Diagram for part labels.

Reference Connection Method(s) 9 for more details.

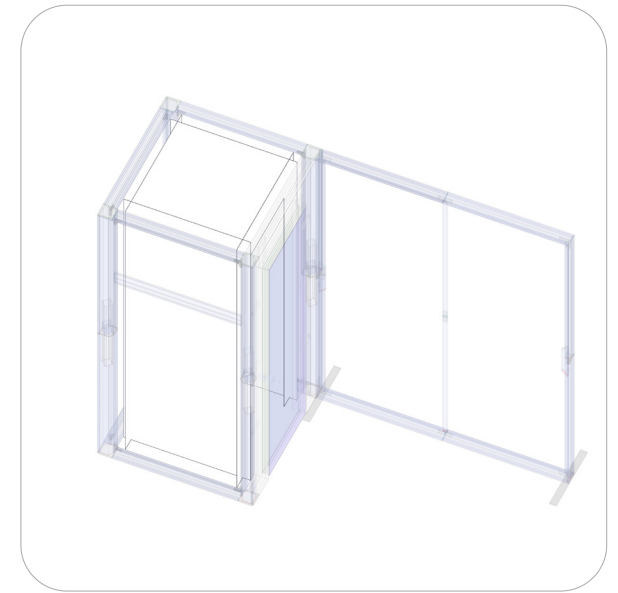
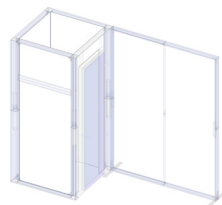

Kit Assembly

Step 8.

Attach outside & front graphics to storage closet & vector frame. Use the Exploded View and the Labeling Diagram for part labels.

Reference Connection Method(s) 9 for more details.

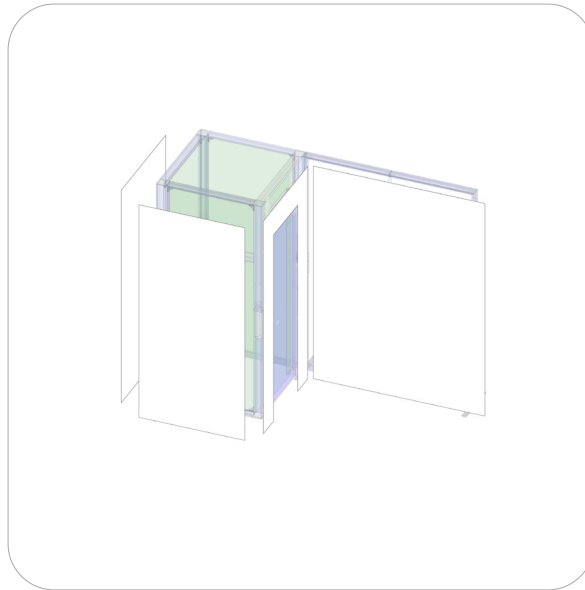
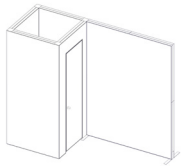

Step by Step

Step 9.

Attach rear liner to vector frame. Use the Exploded View and the Labeling Diagram for part labels.

Reference Connection Method(s) 9 for more details.

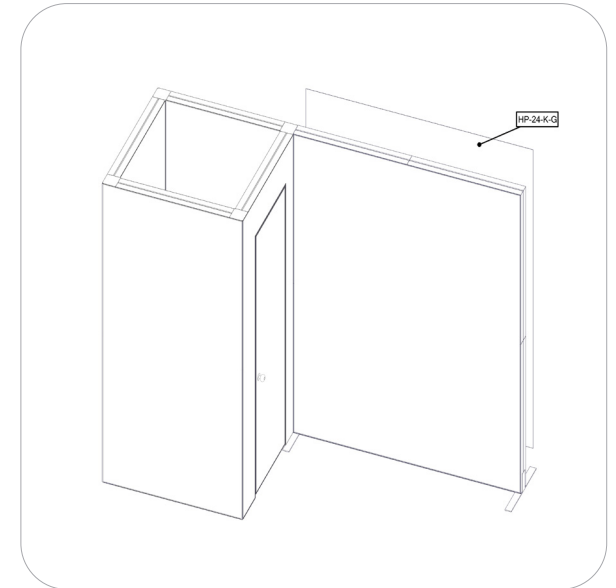
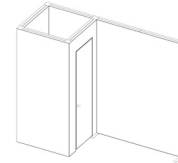

Step 10.

Attach graphics to inside & outside vector door. Use the Exploded View and the Labeling Diagram for part labels.

Reference Connection Method(s) 13 for more details.

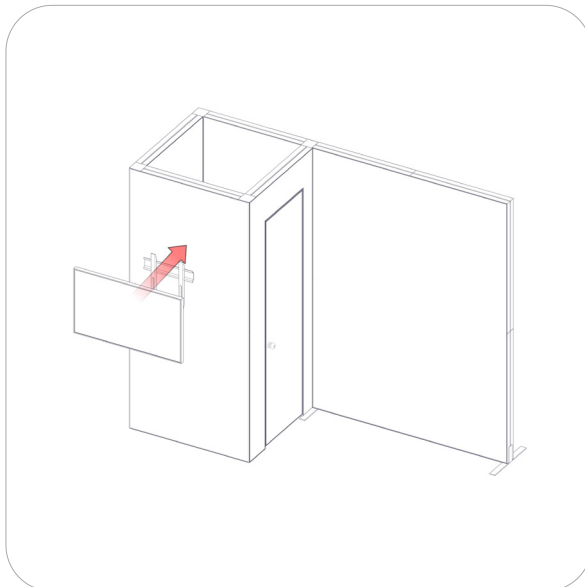
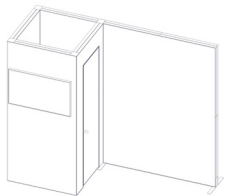

Step 11.

Assemble VFC-04 counter. Detailed PDF With instruction. Details follow this page. Use the Exploded View and the Labeling Diagram for part labels.

Reference Connection Method(s) See attached PDF for more details on the VFC-04 kit.

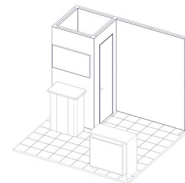

VFC-04

Connection Methods

Connection Method 1: CB9

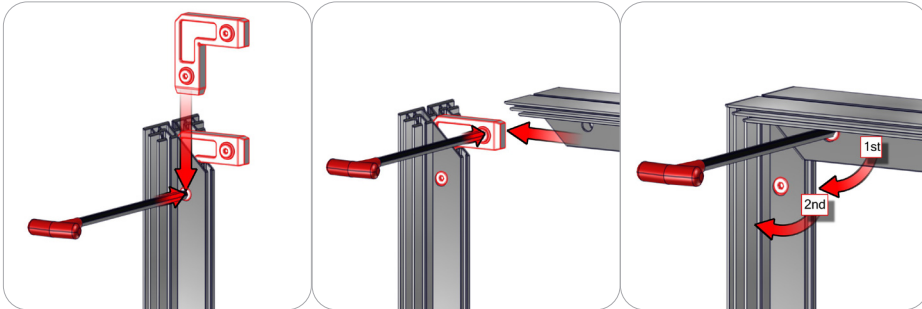

First, insert the corner connector into the extrusion while holding in the lock button with the allen key tool. Second, slide the next extrusion onto the same corner connector while holding in the lock button using the allen key tool. Third, use the allen key tool for locking the corner connector buttons in place. Use the allen key tool to make half turns clock-wise. Do not over tighten the lock buttons.

Connection Method 2: IB2

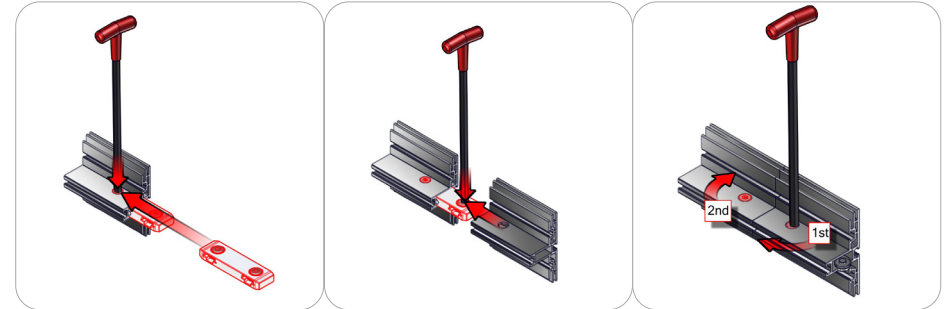

First, insert the in-line connector into the extrusion while holding in the lock button with the allen key tool. Second, slide the next extrusion onto the same in-line connector while holding in the lock button using the allen key tool. Third, use the allen key tool for locking the in-line connector buttons in place. Use the allen key tool to make half turns clock-wise. Do not over tighten the lock buttons.

Connection Method 3: SW-FOOT-500

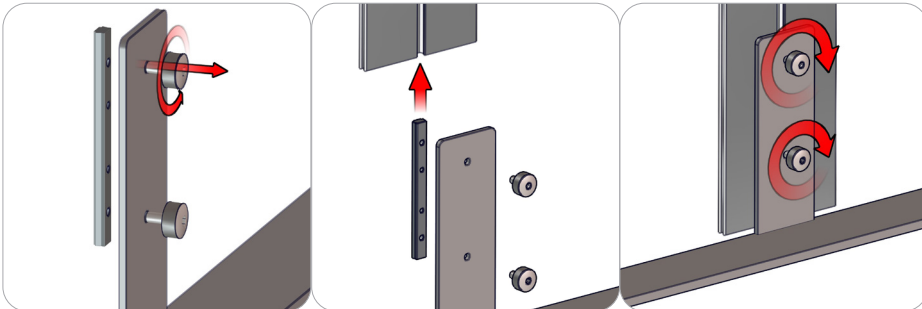

First, loosen the thumb screws and channel bars on the stabilizing bases. Do not disassemble them. Second, slide channel bars into the frame channel flush with the base of the frame. Third, tighten the thumb screws and channel bars securing the attachment. Do not over tighten the thumb screws.

Connection Method 4: AF16

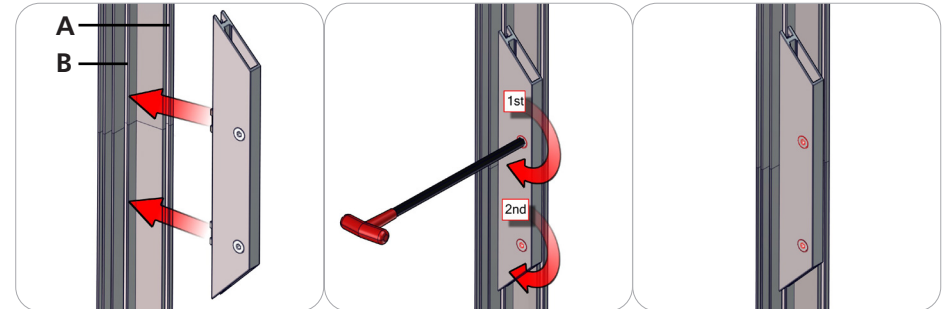

For single sided graphics, attach the AF16 connector into PHFC4 channel (B, featured above). For double sided graphics, attach the AF16 connector into PHFC4 channel (A).

The cam lock buttons should face towards the back of the frame. Be sure to evenly bridge the AF16 on the PHFC4 split for maximum support. Using the allen key tool, engage the cam-lock teeth by turning the buttons a half turn clock-wise. Do not over tighten the cam-lock buttons.

Connection Methods

Connection Method 5: CBE-50

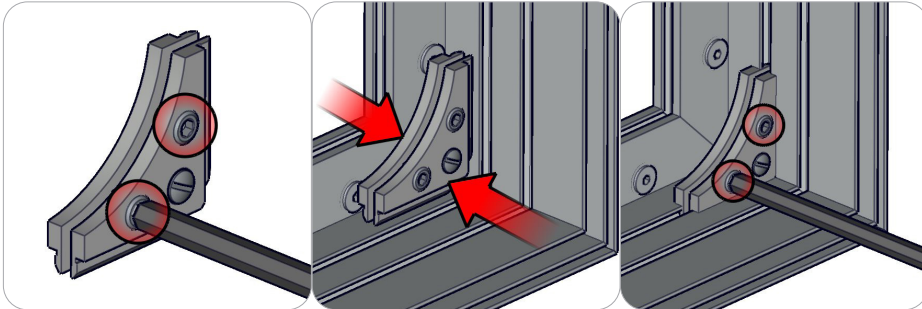

First, use the provided hex tool to loosen the two 5mm hex set screws. Next, compress the bracket and apply it to the corner channel. Then, tighten the set screws. Do not over tighten the set screws. Do not loosen the spring loaded screw.

Connection Method 6: PH1

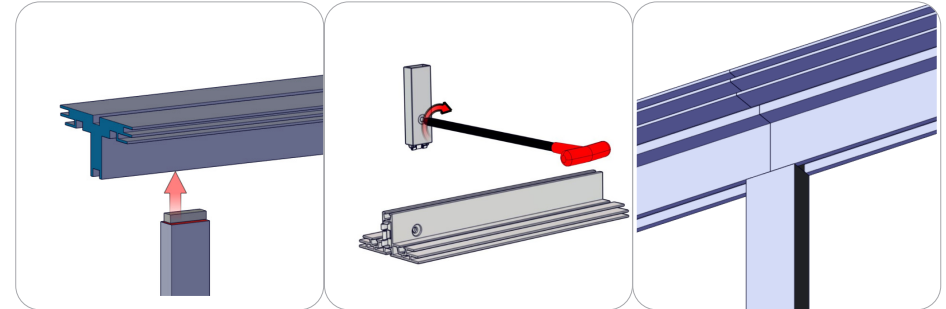

First, place the cam lock teeth into the desired extrusion channel. Second, use the allen key tool to lock the cam buttons in place. Make half turns clock-wise to engage the cam-lock. Do not over tighten the lock buttons.

Connection Method 7: PH1 to PH1

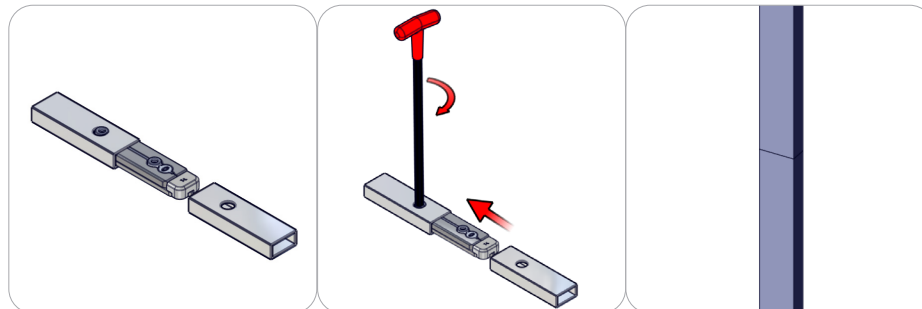

First, insert the in-line connector into the extrusion while holding in the lock button with the allen key tool. Second, slide the next extrusion onto the same in-line connector while holding in the lock button using the allen key tool. Third, use the allen key tool for locking the in-line connector buttons in place. Use the allen key tool to make half turns clock-wise. Do not over tighten the lock buttons.

Connection Method 8: PM4DSC

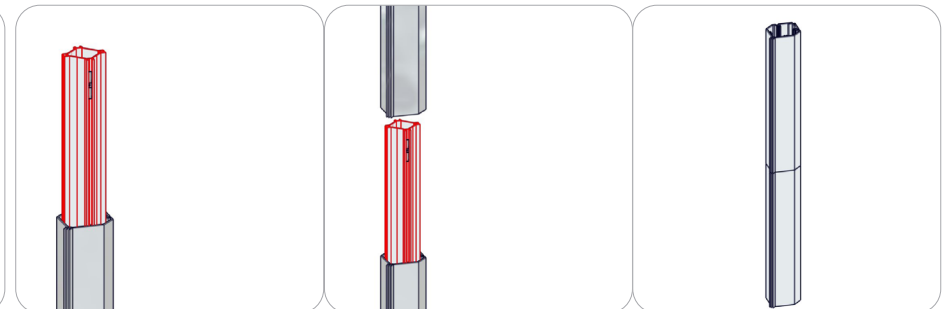

First, slide the PH2C-2 connector into post unit it rest on the PH2C stop. Second, then slide the top post onto the PH2C-2 CONNECTOR. Once connected there should be no gaps between the two.

Connection Methods

Connection Method 9: Graphic Application

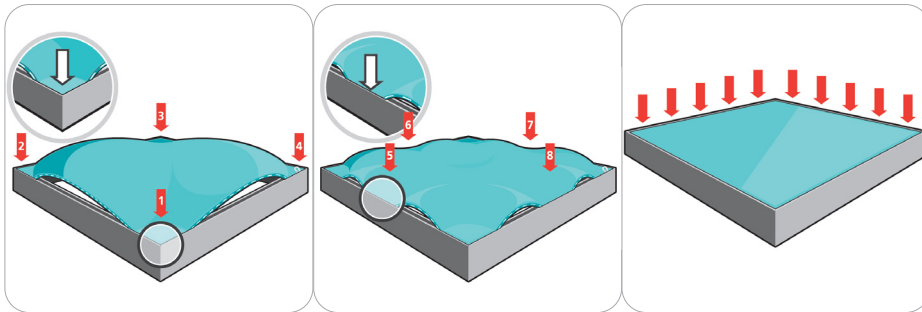

First, insert the silicone edge frame corners into the frame graphic channel (points 1 through 4).
Second, insert the silicone edge frame sides into the frame graphic channel (points 5 through 8).
Third, push the remaining silicone edge fabric into the frame graphic channel.
Similar setup is recommended for the opaque liner.
To remove these panels, simply pull the loop tag sewn near a corner.

Connection Method 10: PMF4-90

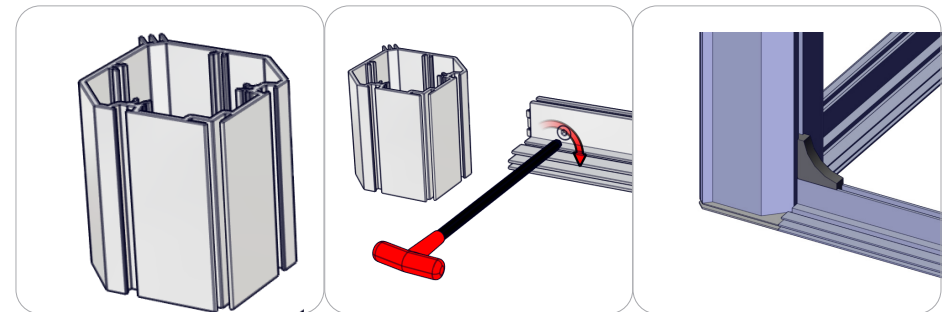

First, loosen the thumb screws and channel bars on the stabilizing bases. Do not disassemble them.
Second, slide channel bars into the frame channel flush with the base of the frame.
Third, tighten the thumb screws and channel bars securing the attachment. Do not over tighten the thumb screws.

Connection Method 11: PMFC-90 CAP

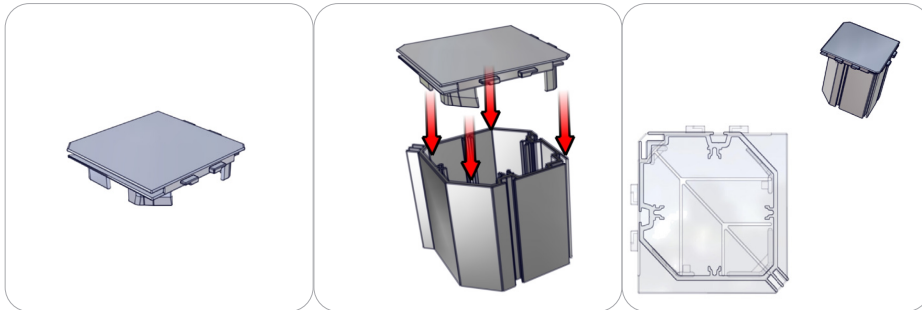

A line plastic clips of cap to extrusion. Once a lined should fit. Do not force cap on, for this could damage the cap.

Connection Method 12: PMFC4-90 to PH1

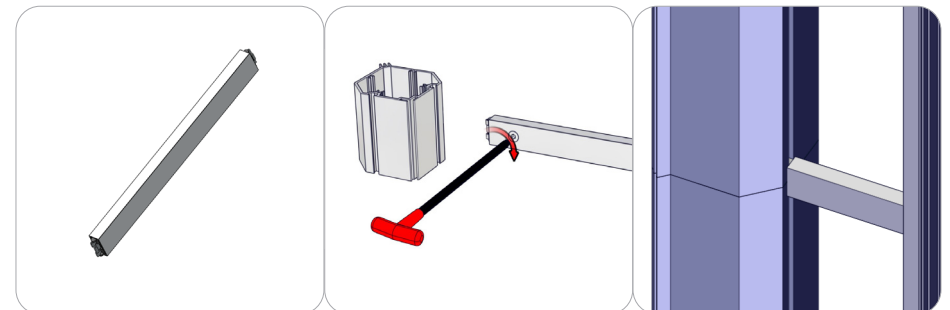

First, place the cam lock teeth of the PH1 into the desired extrusion channel of the PMFC4-90.
Second, use the allen key tool to lock the cam buttons in place. Make half turns clock-wise to engage the cam-lock. Do not over tighten the lock buttons.

Connection Methods

Connection Method 13: EMT-M-MB

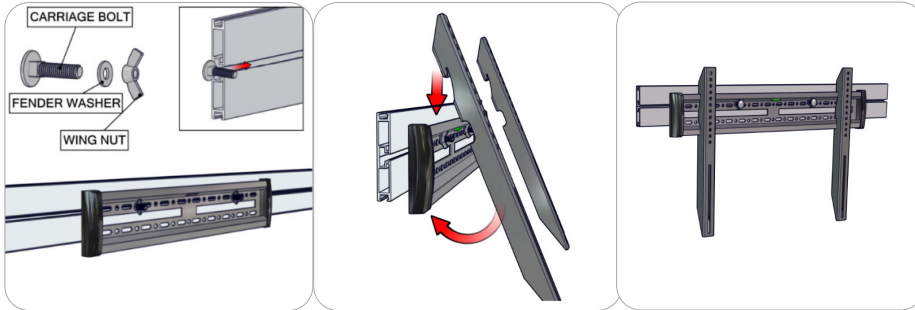

First, insert bolts into proper channel. Then secure monitor mount with washers & wing nuts. Second, attach monitor to brackets see NB manual for more info.

Connection Method 14: PS2

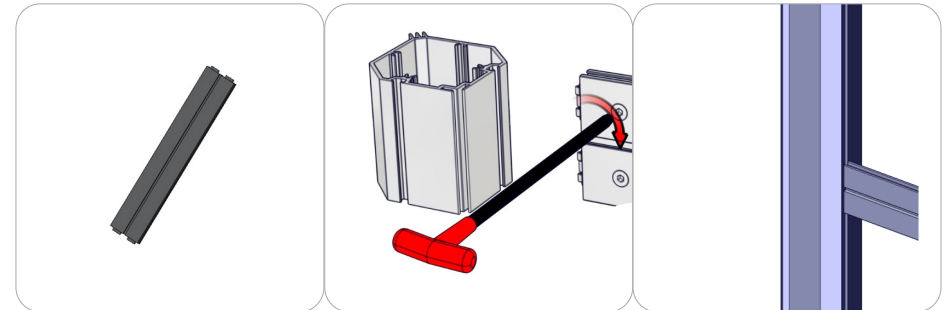

First, place the cam lock teeth of the PS2 into the desired extrusion channel of the PMFC4-90. Second, use the allen key tool to lock the cam buttons in place. Make half turns clock-wise to engage the cam-lock. Do not over tighten the lock buttons.

Connection Method 15: LOCKING VECTOR FRAME & STORAGE CLOSET TOGETHER CAM LOCKS

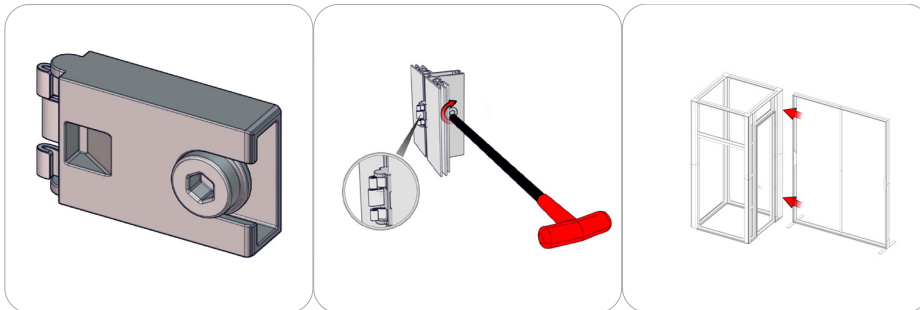

First, place the cam lock EMBEDDED IN THE PHFC4 into the desired extrusion channel of the PMFC4-90. Second, use the allen key tool to lock the cam buttons in place. Make half turns clock-wise to engage the cam-lock. Do not over tighten the lock buttons.

Vector Frame Counter 04

VFC-04

Vector Frame™ counters compliment the Vector Frame series of exhibit kits, but are also ideal for any stand-alone event or display. Vector Frame counters couple simple extrusion-based frames with push-fit graphics. Countertops are available in four colored finishes. Custom sizes also available.

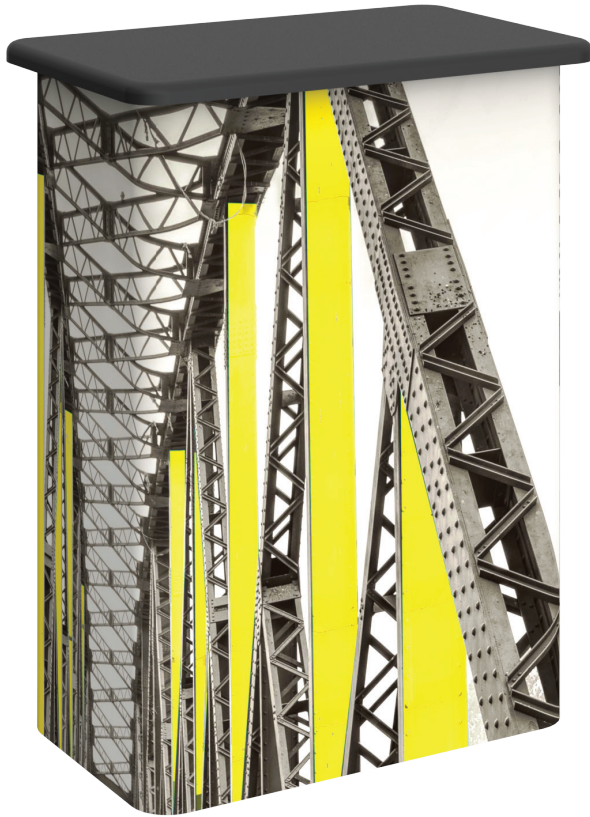





We are continually improving and modifying our product range and reserve the right to vary the specifications without prior notice. All dimensions and weights quoted are approximate and we accept no responsibility for variance. E&OE. See Graphic Templates for graphic bleed specifications.

features and benefits:

- Feature push-fit fabric graphics and simple extrusion based frames
- Choose from four countertop finishes
- Easy step-by-step instructions
- Wheeled portable shipping case
- Lifetime limited warranty against manufacturer defects

dimensions:

Hardware	Graphic
<p>Assembled unit: 31" w x 40.5" h x 19" d 1400mm(w) x 1029mm(h) x 572mm(d)</p> <p>Approximate unit weight: 52 lbs / 24 kg</p>	<p>Refer to related graphic template for more information</p> <p>Visit: www.exhibitors-handbook.com/graphic-templates</p>
Shipping	
<p>Packing case(s) 1 OCH2</p> <p>Shipping dimensions: 52" l x 29" h x 15" d 1321mm(l) x 737mm(h) x 381mm(d)</p> <p>Approximate shipping weight: 82 lbs / 37 kg</p>	
additional information:	
<p>Graphic material: Dye-sublimation SEG push-fit fabric</p> <p>Counter holds max weight 100 lbs / 46 kg</p>	
<p>Tabletop Colors:</p> <div style="display: flex; justify-content: space-around; align-items: center;"> <div style="text-align: center;">  silver </div> <div style="text-align: center;">  black </div> <div style="text-align: center;">  mahogany </div> <div style="text-align: center;">  natural </div> </div>	

Included In Your Kit

Tools, Components, & Connectors



5MM ALLEN-T x1

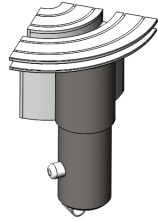

CB10-R x8

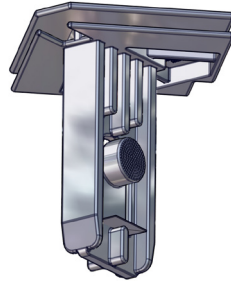

PMFC2-90-CAP x4

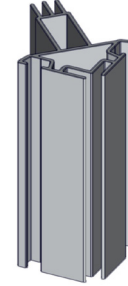

PMFC2-90-986-L1-L1 x2

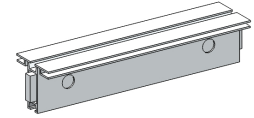

PHFC2-600-L-L x2

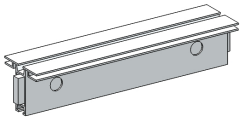

PHFC2-300-L-L x4

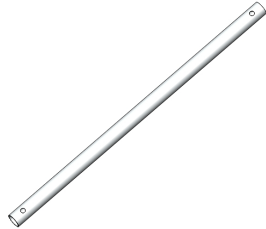

TUBE-30-910 x4

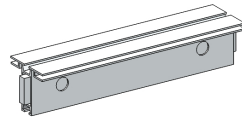

PHFC2-100-L-L x4

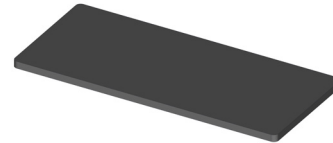

VFC-04-CT-S x1

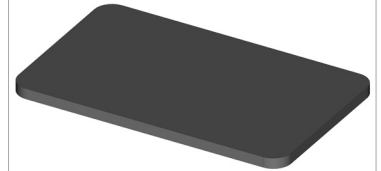

VFC-04-CT x1



PE-1000 x2

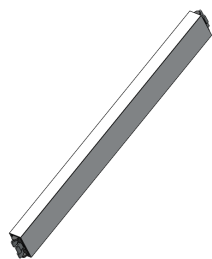

PH1-288-L-L x4

Graphics



VFC-04-A-G x1

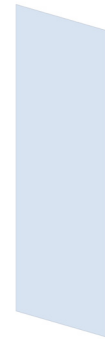

VFC-04-B-G x1

Exploded View

VFC-04
Section 1

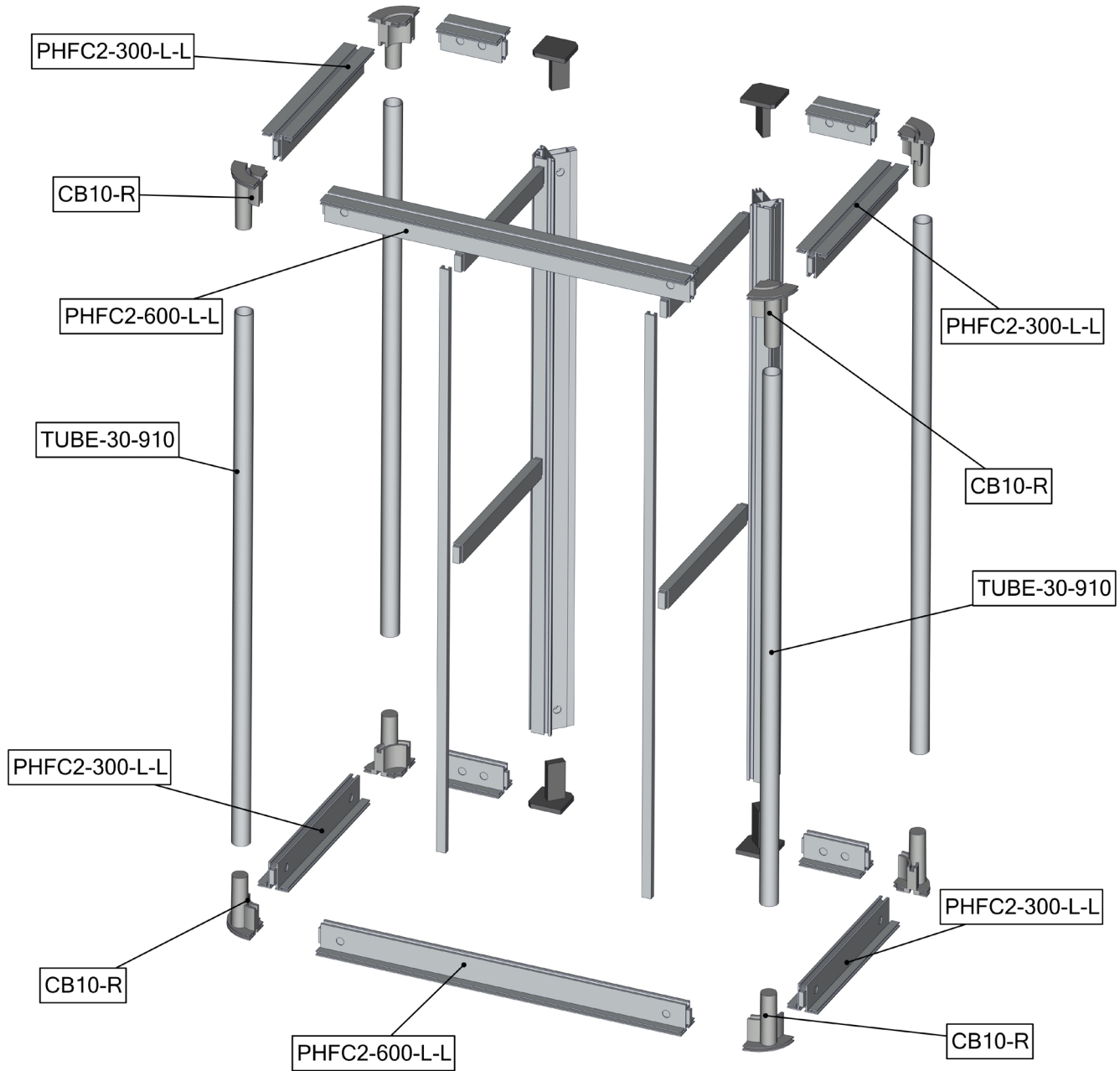

Exploded View

VFC-04
Section 2

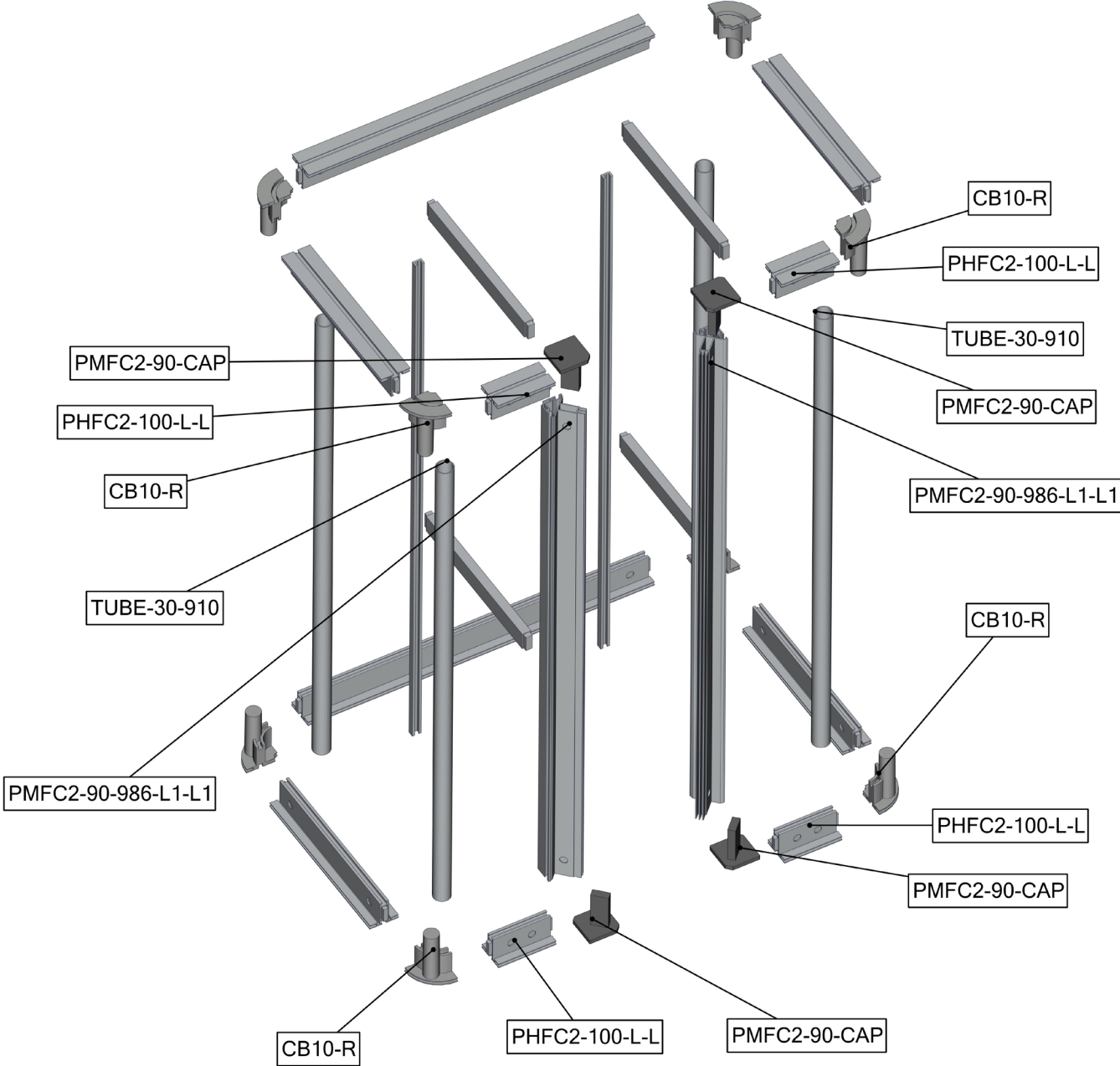

Exploded View

VFC-04
Section 3

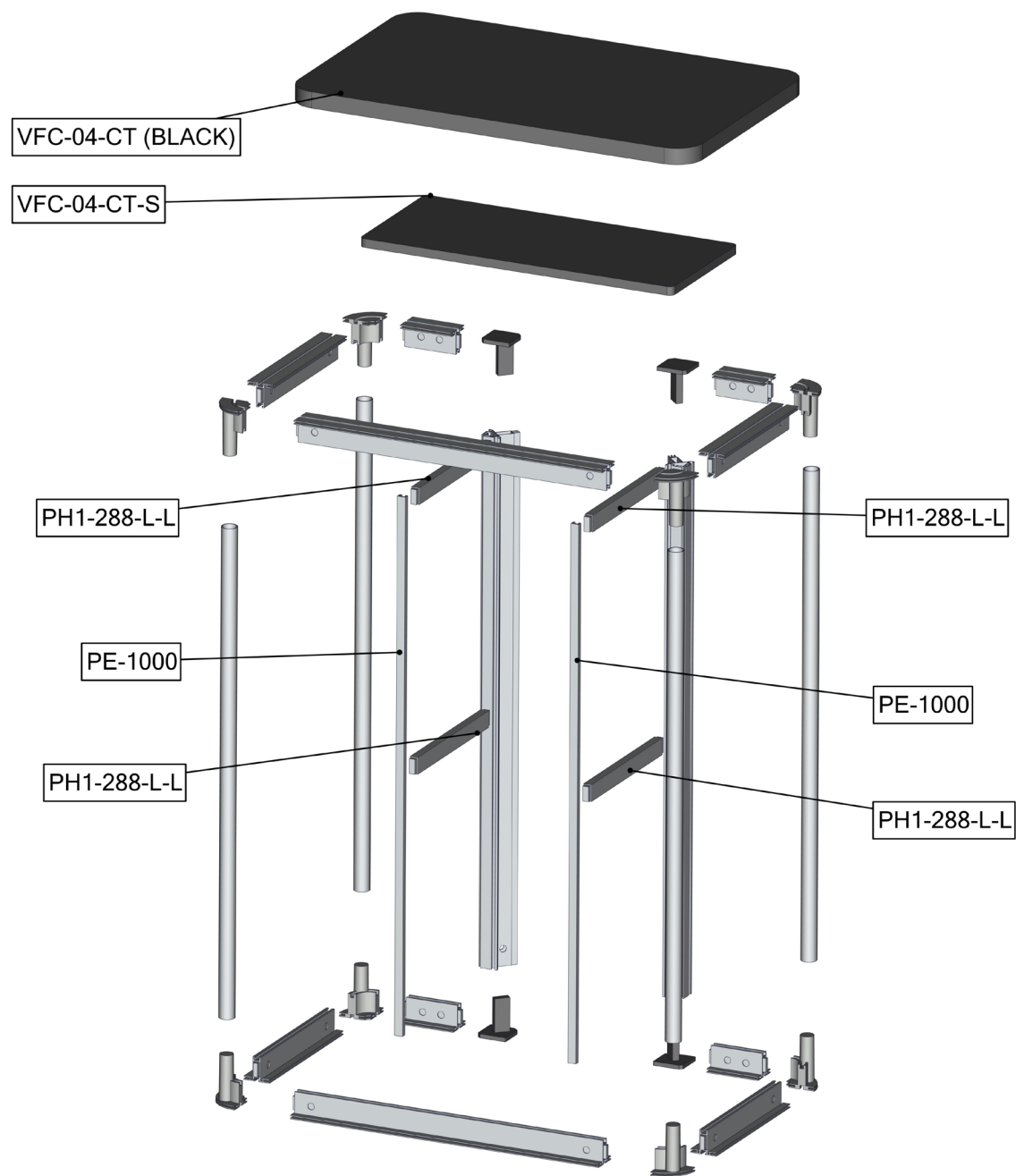

Kit Assembly

Step by Step

Step 1.

Gather the components to build the counter frame sections 1 and 2. Use the Exploded View section 1 and 2 for part labels.

Reference Connection Method(s) 1, 2 and 3 for more details.

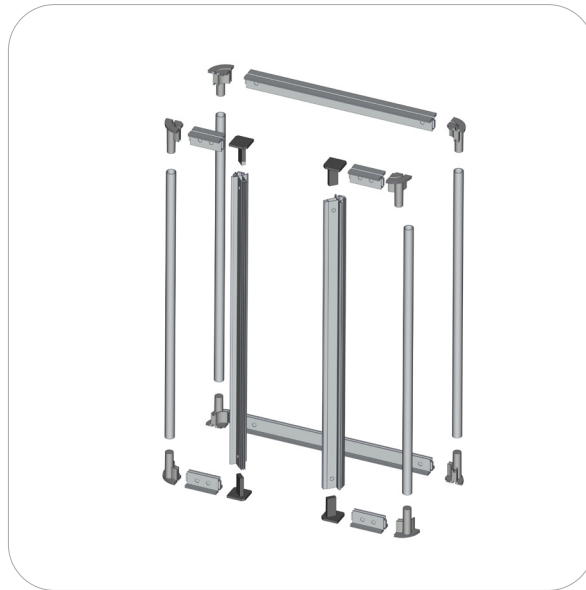

Step 2.

Gather the components to build the counter frame section 3. Use the Exploded View section 3 for part labels. Use section 3 to merge sections 1 and 2.

Reference Connection Method(s) 2, 3 and 4 for more details.

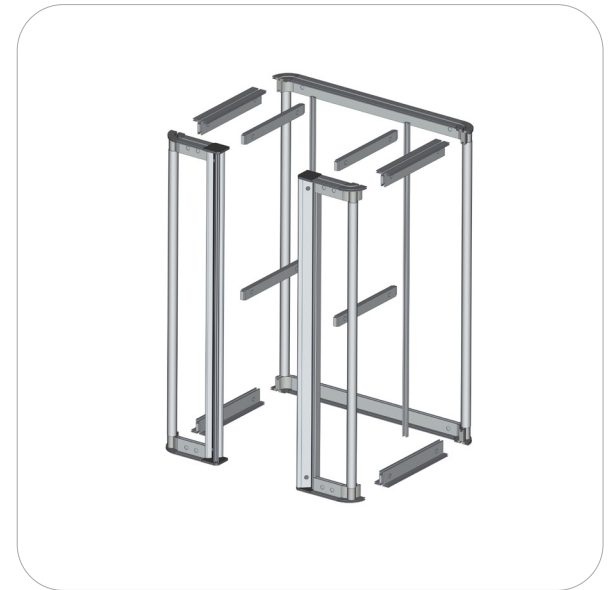

Step 3.

Apply the counter fabric graphics by pressing the edges of the graphic into the extrusion fabric channel.

Reference Connection Method 5 for more details.

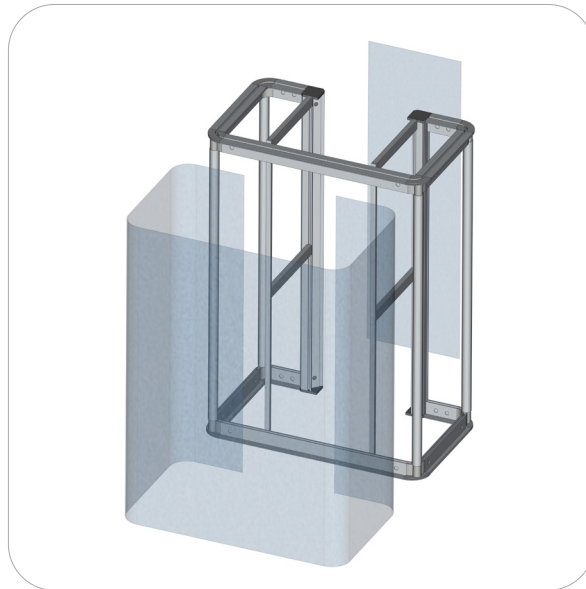
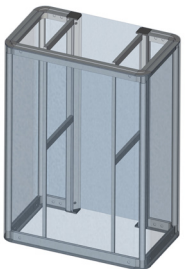

Step 4.

Gather the components to build the counter top and shelf. Use the Exploded View section 3 for part labels.

Reference Connection Method 6 for more details.

Setup is complete.

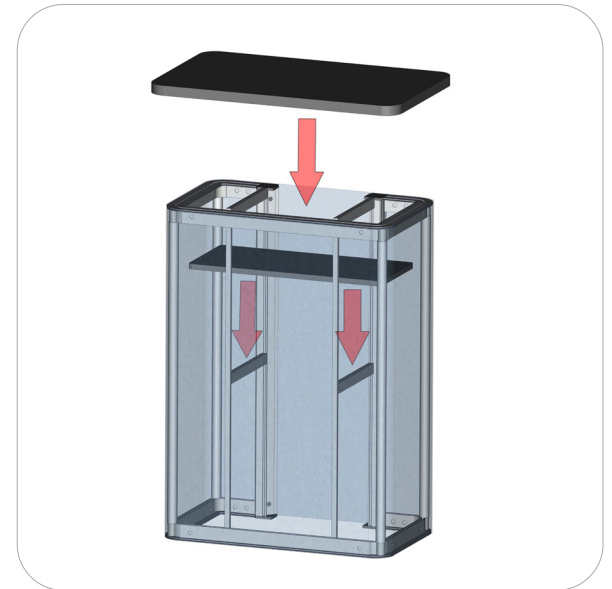
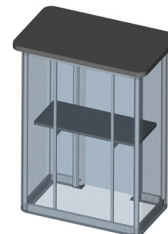

Connection Methods

Connection Method 1: PMFC2-90-CAP

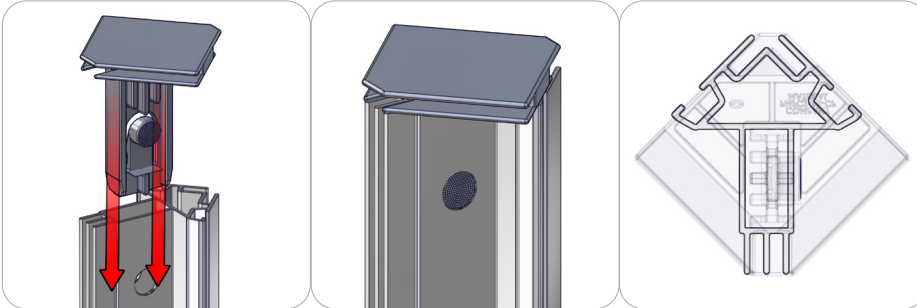

First, press button to insert the cap into the extrusion. The button will snap in place.

Connection Method 2: PMFC2 / PHFC2



First, with the cam lock disengaged, place the cam lock teeth into the extrusion channel. Second, use the allen key tool to lock it in place. Make half turns clock-wise to engage the cam lock. Do not over tighten the lock buttons.

Connection Method 3: CB10-R / PHFC2

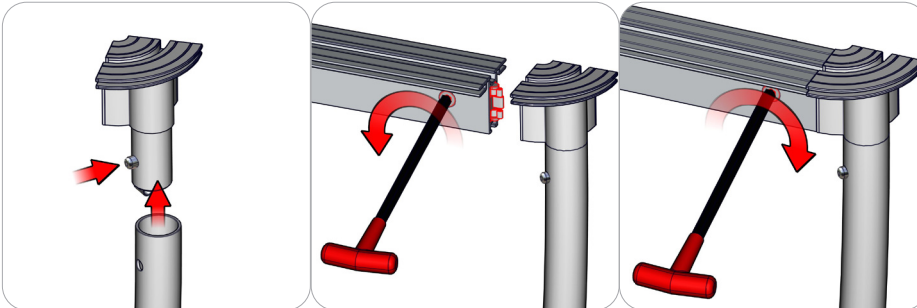

First, press and hold the snap button while you slide it into the tube. The snap button connection is secure when it protrudes through the tube hole. Second, using the allen key tool, disengage the cam lock in the extrusion end and place its teeth into the CB10-R channel. Third, with the cam lock teeth in the channel, use the allen key tool to engage the cam lock. Make a half turn to lock, do not over tighten. Repeat for opposite end.

Connection Method 4: CAM LOCK / PE

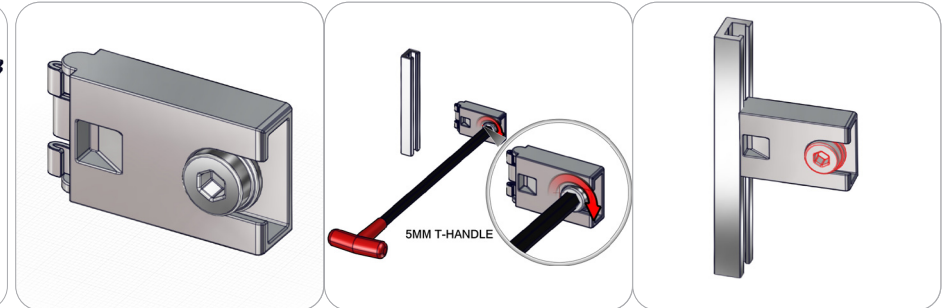

First, with the cam lock disengaged, place the cam lock teeth into the extrusion channel. Second, use the allen key tool to lock it in place. Make half turns clock-wise to engage the cam lock. Do not over tighten the lock buttons.

Connection Methods

Connection Method 5: Silicon Edge (SEG)

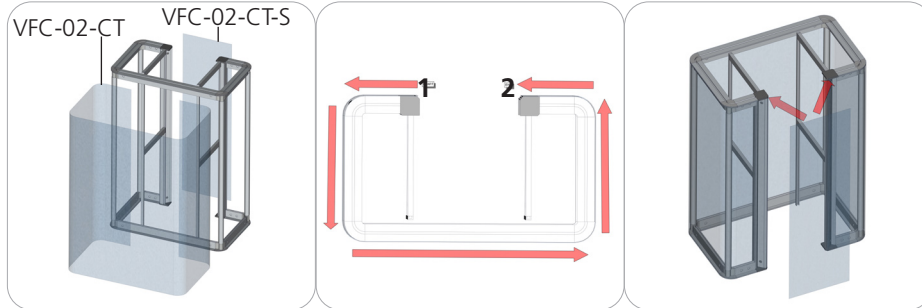

First, at START point 1, start pressing VFC-04-A-G fabric SEG from top to bottom of the counter fabric channels. Second, work the SEG across the rest of the top and bottom counter fabric channels to END point 2. At END point 2, start pressing the fabric SEG from top to bottom of the counter fabric channel. Third, apply VFC-04-B-G fabric SEG from top to bottom of the counter fabric channels.

Connection Method 6: Counter Top

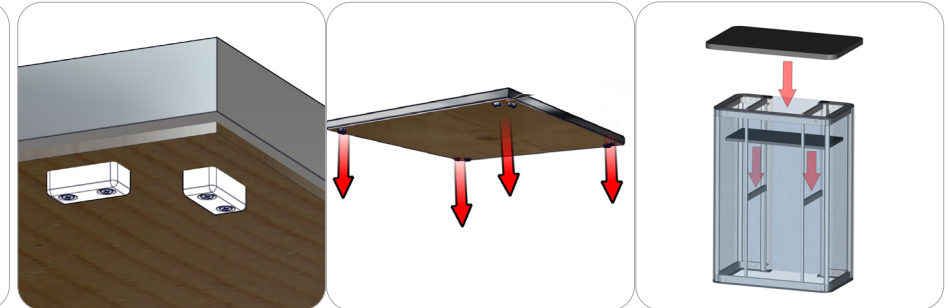

Counter top is held into place by the blocks seen about.

Monitor Bracket Instructions

Extrusion Channel Applications

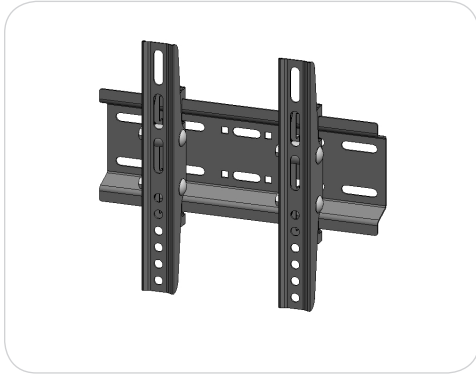

EXT-SM-MB

Vesa Pattern: 75 x 75
up to 200 x 200mm

Max weight varies per application

Assembled unit:

10" w x 8.86" h x 2" d
255mm (w) x 225mm (h) x 50mm (d)

Shipping dimensions:

14" l x 6" h x 4" d
356mm (l) x 152mm (h) x 102mm (d)

Approximate total shipping weight:

6 lbs / 3 kg

Recommended monitor sizes:

23" - 42"

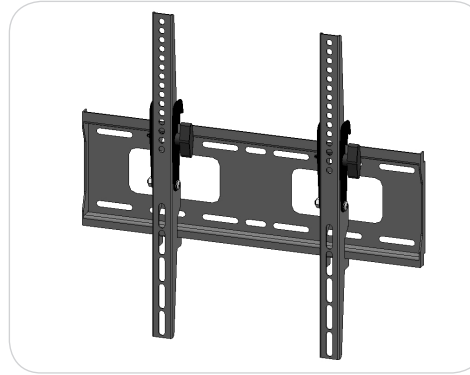

EXT-M-MB

Vesa Pattern: 200 x 200
up to 400 x 400mm

Max weight varies per application

Assembled unit:

17.6" w x 16.7" h x 1.6" d
448mm (w) x 425mm (h) x 40mm (d)

Shipping dimensions:

24" l x 4" h x 4" d
610mm (l) x 102mm (h) x 102mm (d)

Approximate total shipping weight:

8 lbs / 4 kg

Recommended monitor sizes:

32" - 55"

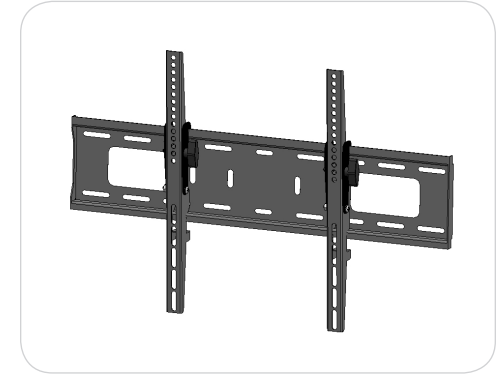

EXT-LG-MB

Vesa Pattern: 200 x 200
up to 600 x 400mm

Max weight varies per application

Assembled unit:

25.9" w x 16.7" h x 1.6" d
658mm (w) x 425mm (h) x 40mm (d)

Shipping dimensions:

28" l x 6" h x 6" d
711mm (l) x 152mm (h) x 152mm (d)

Approximate total shipping weight:

9 lbs / 5 kg

Recommended monitor sizes:

37" - 70"

Included hardware:

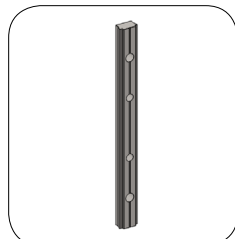

LN-100

x2



M5 x 10

LN-LCD-SCW

x2

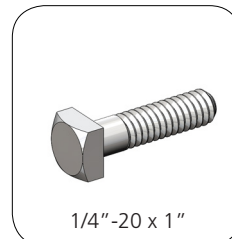

1/4"-20 x 1"

BOLT-1

x2

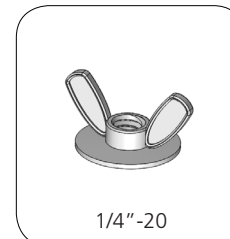

1/4"-20

Flange Wing nut

x2

Extrusion Connection

Channel Connection A

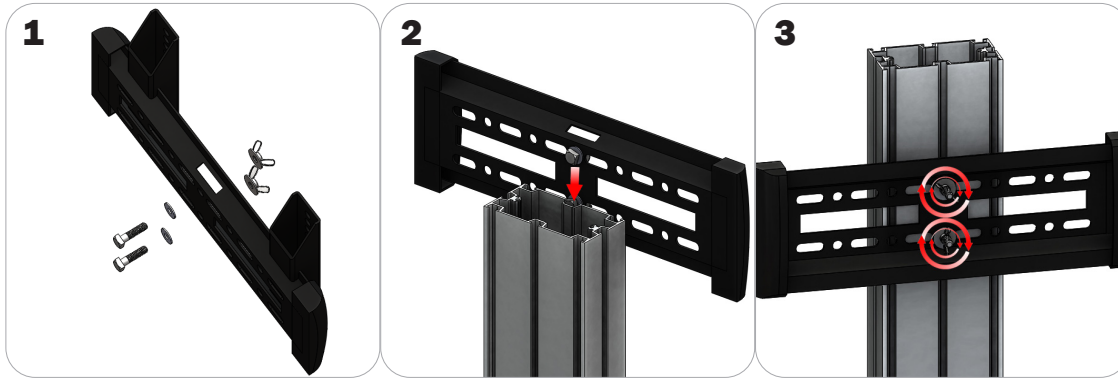

Locate all components needed to assemble the monitor mount with the channel connection A method. You will need (1) monitor bracket, (2) square head bolts, (2) washers, and (2) wing nuts.

Step 1: Insert the provided bolts through the washers and center top and bottom holes of the monitor mount. Loosely thread your wing nuts onto the end of the bolts.

Step 2: Slide the bolt heads down the extrusion channel.

Step 3: Tighten your wing nuts to lock the monitor bracket in place.

Step 4: Reference the included manufacturer monitor mount instructions for fastening your monitor to the bracket.

Channel Connection B

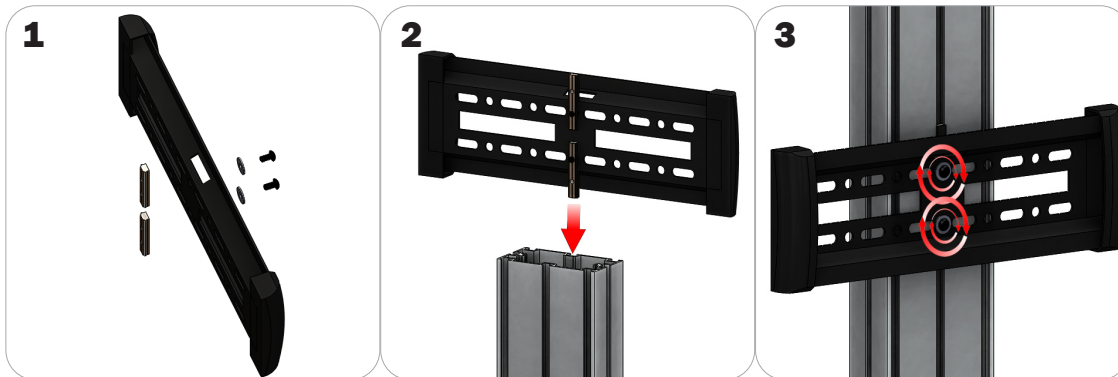

Locate all components needed to assemble the monitor mount with the channel connection B method. You will need (1) monitor bracket, (2) LN-LCD-SCW, (2) LN-100, and (2) washers.

Step 1: Loosely thread the LN-LCD-SCW screws through the washers, the center top and bottom holes of the monitor bracket, and through the LN-50 holes.

Step 2: Slide the LN-100s down the extrusion channel.

Step 3: Tighten your LN-LCD-SCW to lock the monitor bracket in place.

Step 4: Reference the included manufacturer monitor mount instructions for fastening your monitor to the bracket.

Extrusion Connection

TRI-30MM Channel Tube Connection

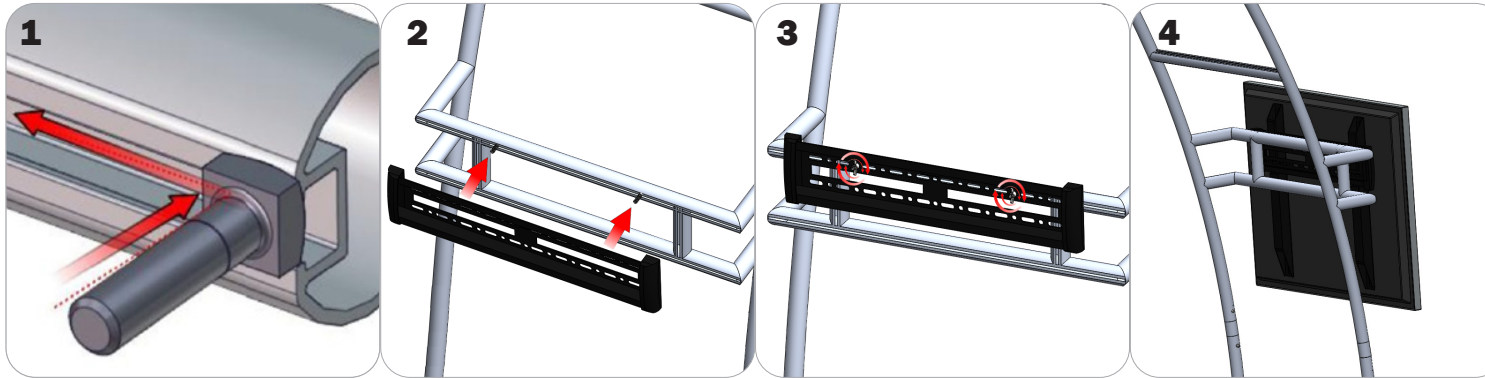

Locate all components needed to assemble the monitor mount with the TRI-30MM Channel Tube Connection method. You will need (1) monitor bracket, (2) Square Bolts, and (2) Wingnuts.

Step 1: Slip the head of the square bolts into the extrusion channel of the tube.

Step 2: Apply your monitor bracket to the protruding square bolts.

Step 3: Lock your monitor bracket to the square bolts using the provided wingnuts.

Step 4: Reference the included manufacturer monitor mount instructions for fastening your monitor to the bracket.