

Hybrid Pro 10FT Modular Backwall Kit 27

HP-K-27

Hybrid Pro™ Modular Kit 27 is a minimal, yet sophisticated modular exhibit that features a seamless fabric backwall with three shelves for small product display. Experience how less is more with this simple and sophisticated modular display.



features and benefits:

- Silver aluminum extrusion frame
- SEG push-fit fabric graphics
- Three shelves for small product display; each shelf holds max 15 lbs
- Shelf color options: Silver, Black, Mahogany, Natural

- Ships freight in a protective plastic freight case
- Lifetime hardware warranty against manufacturer defects

dimensions:

Hardware

Graphic

Assembled unit:
221.19" w x 95.45" h x 68.92" d
5619mm(w) x 2425mm(h) x 1751mm(d)

Approximate weight:
152 lbs / 69 kg

Refer to related graphic template for more information.

Visit:
<https://www.theexhibitorshandbook.com/download-graphic-templates>

Shipping

Packing case(s):
OFC2

Shipping dimensions:
OFC2
51" l x 23" h x 51" d
1296mm(l) x 585mm(h) x 1296mm(d)

Approximate total shipping weight:
222 lbs / 101 kg

additional information:

Graphic material:
Dye-sublimation zipper pillowcase fabric
Dye-sublimation SEG push-fit fabric

When included in a larger kit, a different packaging solution will be listed to accommodate all contents of the kit. Individual packaging no longer provided.

Tabletop Colors:



silver black mahogany natural

2 person assembly recommended:



This product may include the following materials for recycle:
aluminum, select wood, fabric, cardboard, paper, steel, and plastics.

We are continually improving and modifying our product range and reserve the right to vary the specifications without prior notice. All dimensions and weights quoted are approximate and we accept no responsibility for variance. E&OE. See Graphic Templates for graphic bleed specifications.

Included In Your Kit

Tools, Components, & Connectors

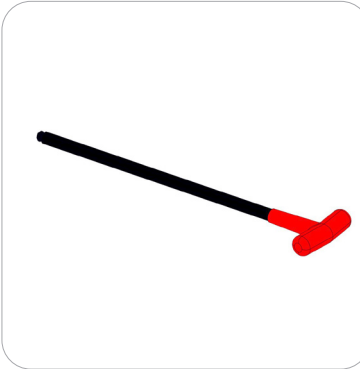

ALLEN KEY 5MM x1



CB9 x4



IB2 x5

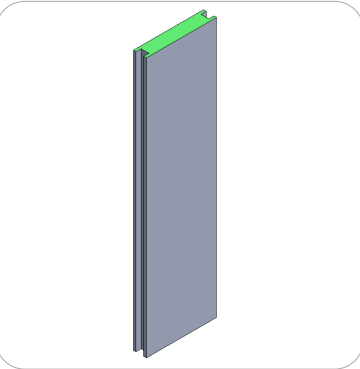

PH2-300-TG x2

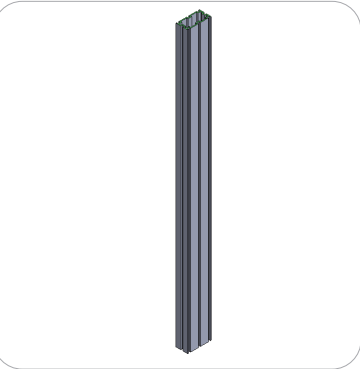

PM4S3-1200-A165 x2

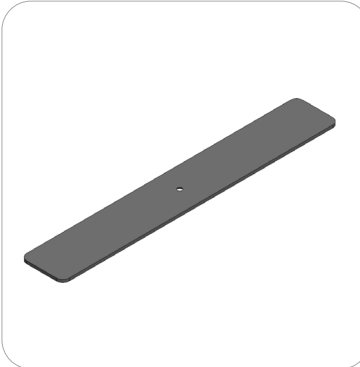

LN114-S2-650 x2



PH1-1155-L-L1 x2

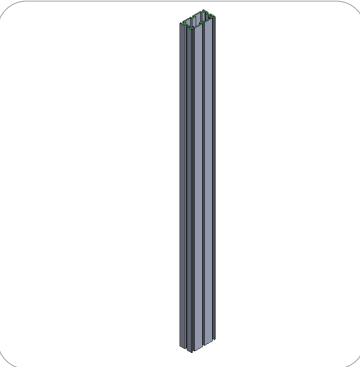

PM4S3-1200-A165-N x2

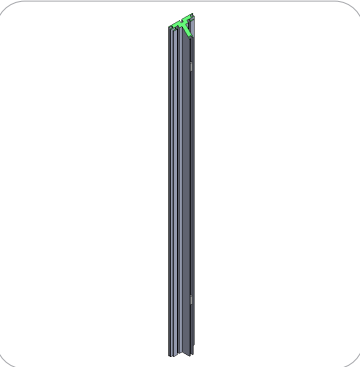

PHFC4-1200-L1-MCB9-SIDE x4



PHFC4-1200-L1-MCB9 x4

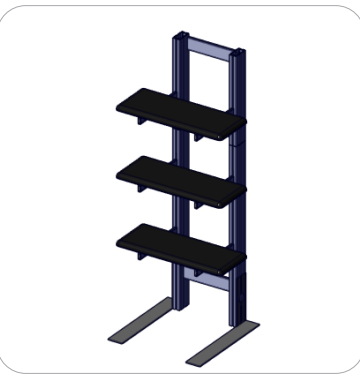

PM4S3-MK-SHELF-UNIT x1

Included In Your Kit

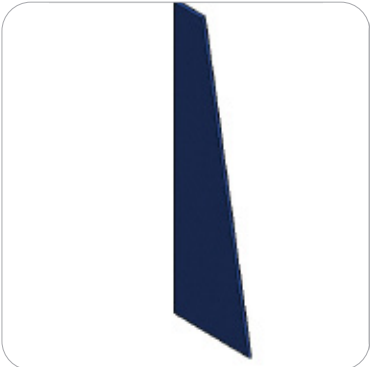

HP-27-A-G x1

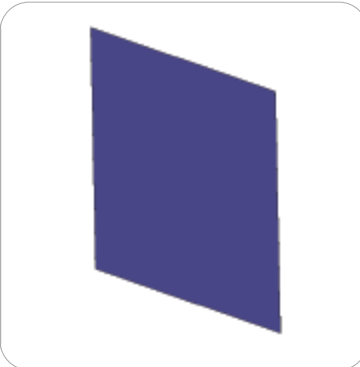

HP-27-B-G x1

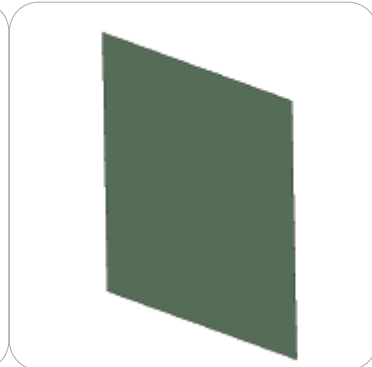

HP-27-D-G x1

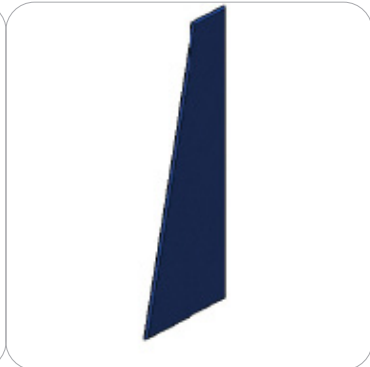

HP-27-C-G x1

Graphics

Included In Your Kit



T2 x1



T4 x1

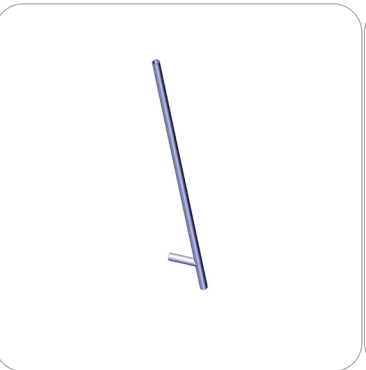

T5 x1

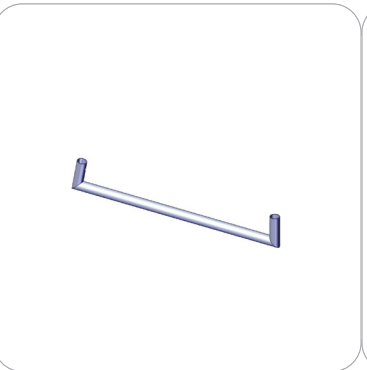

T1 x1

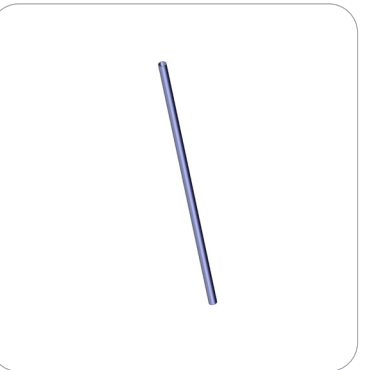

T7 x2

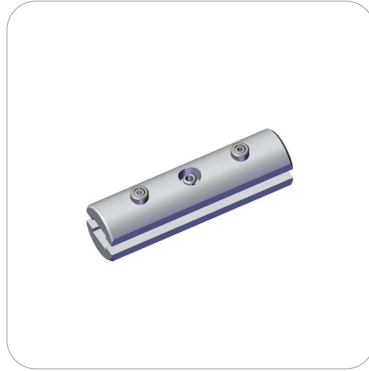

ES30 x7

Tubes HP-FS-7

Included In Your Kit

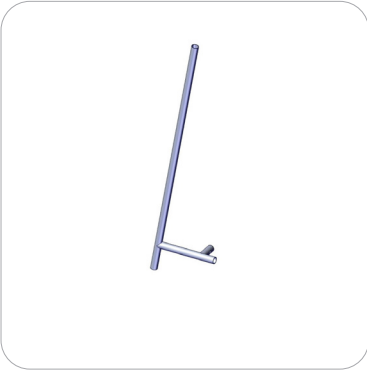

T6 x1



T3 x1

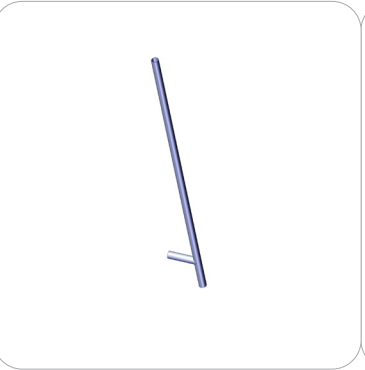

T5 x1

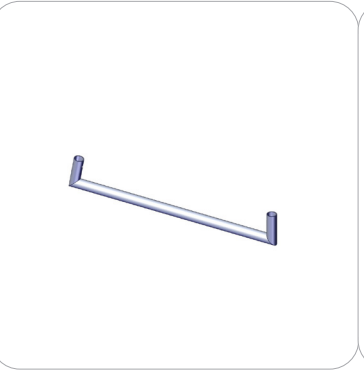

T1 x1

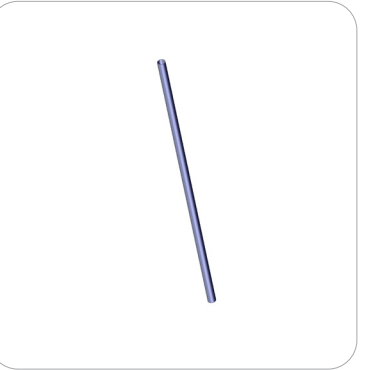

T7 x2

Tubes HP-FS-8



ES30 x7

Exploded Diagram

HP-K-27

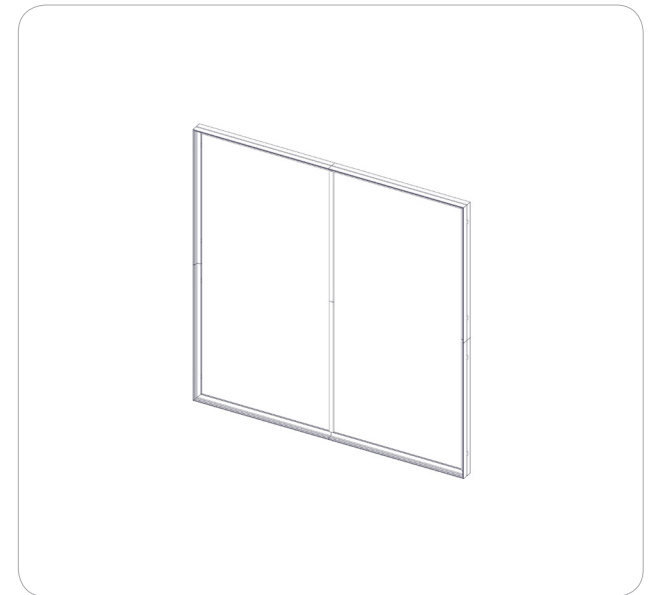
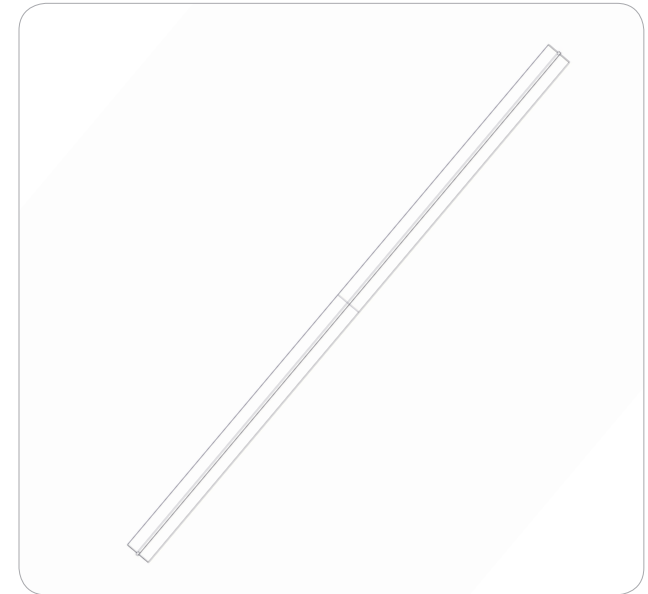
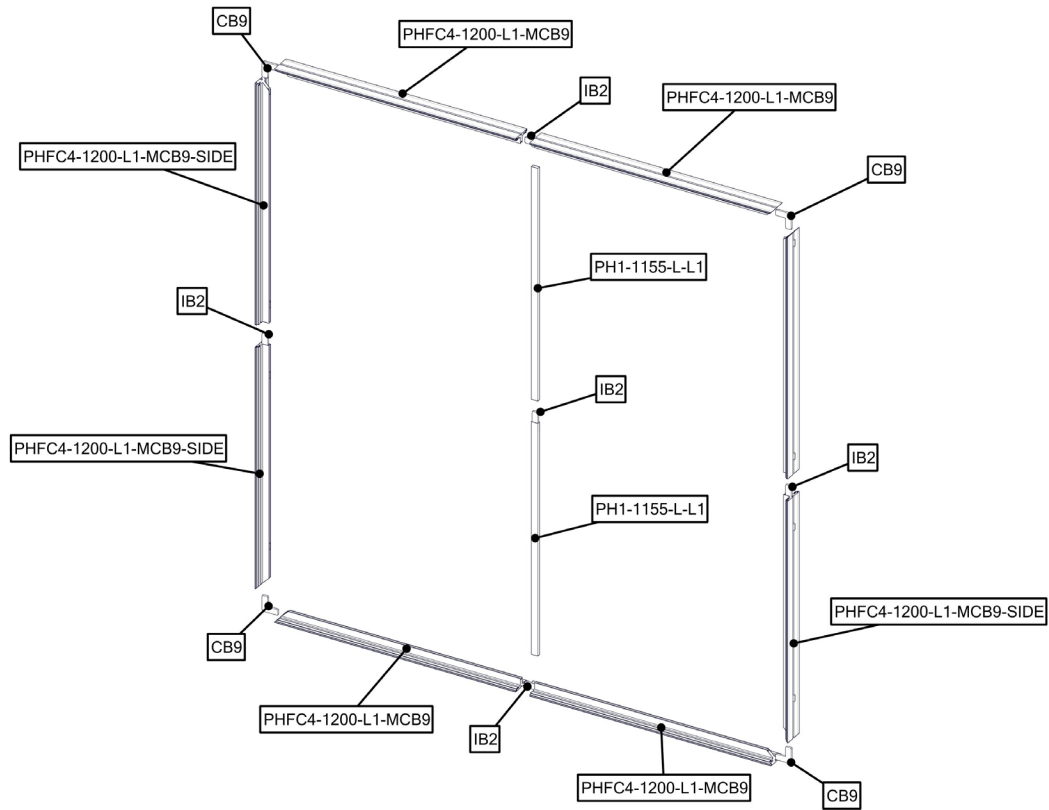

Exploded Diagram

HP-K-27

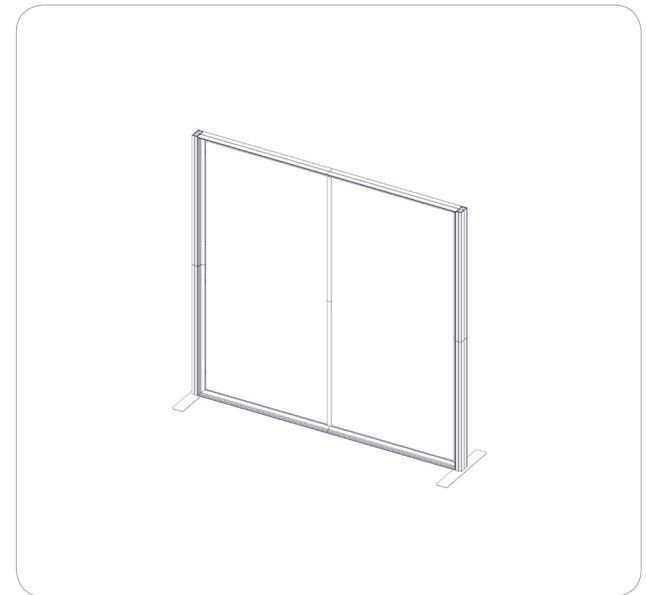
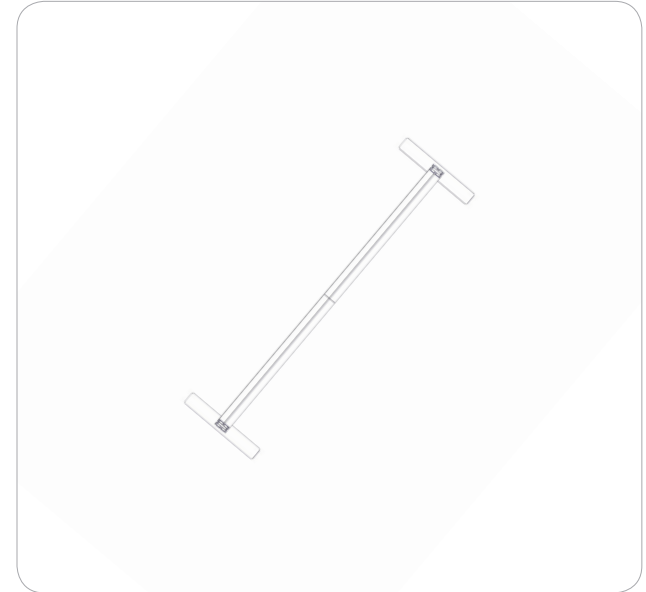
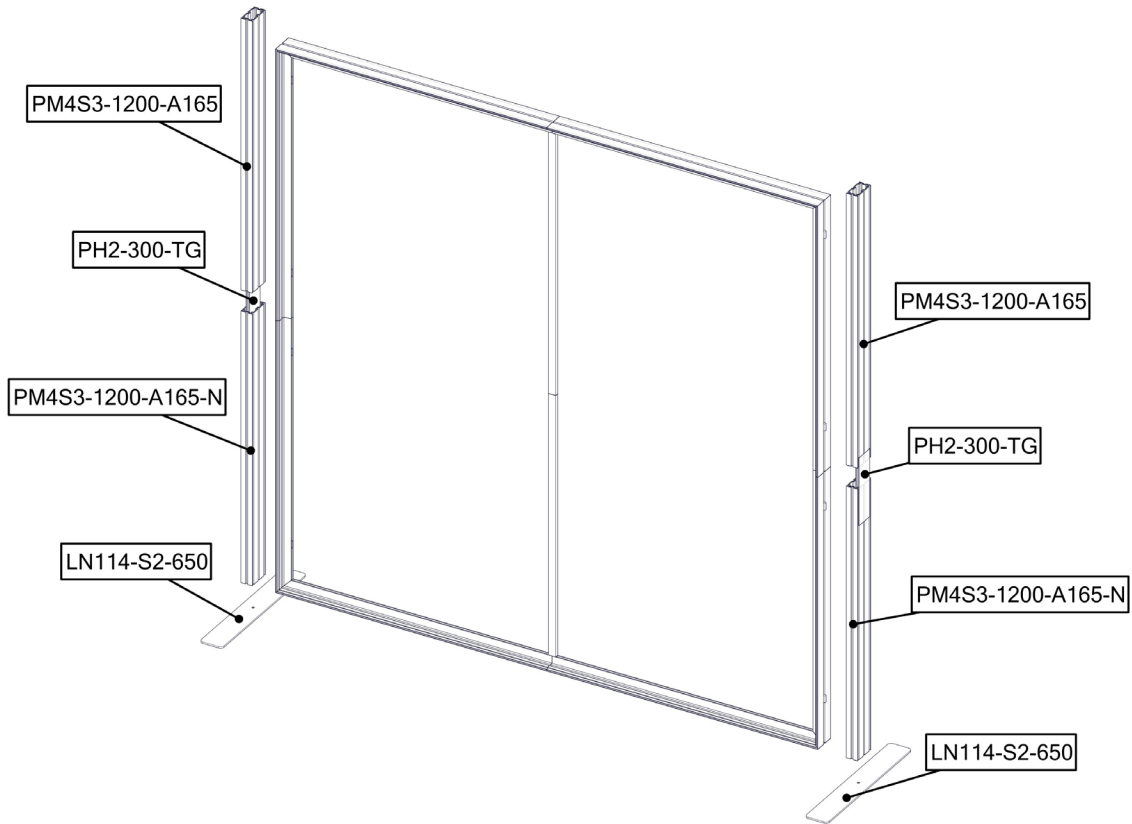

-ASSEMBLE SIDE SUPPORT COLUMNS

Exploded Diagram

HP-K-27

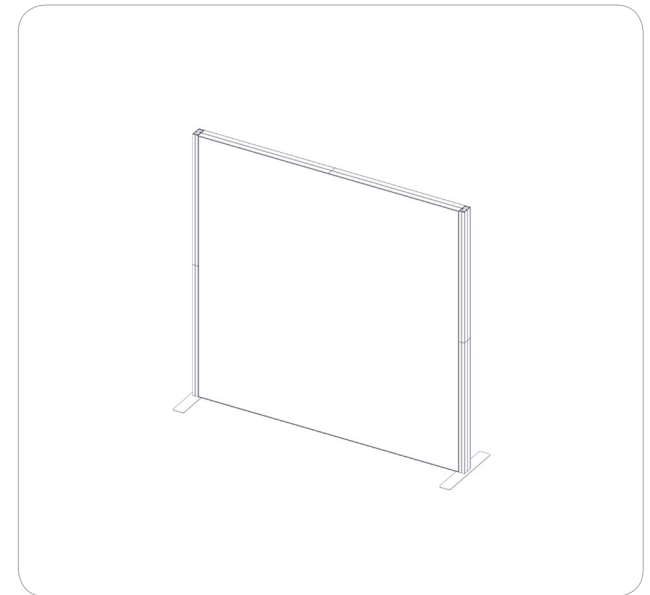
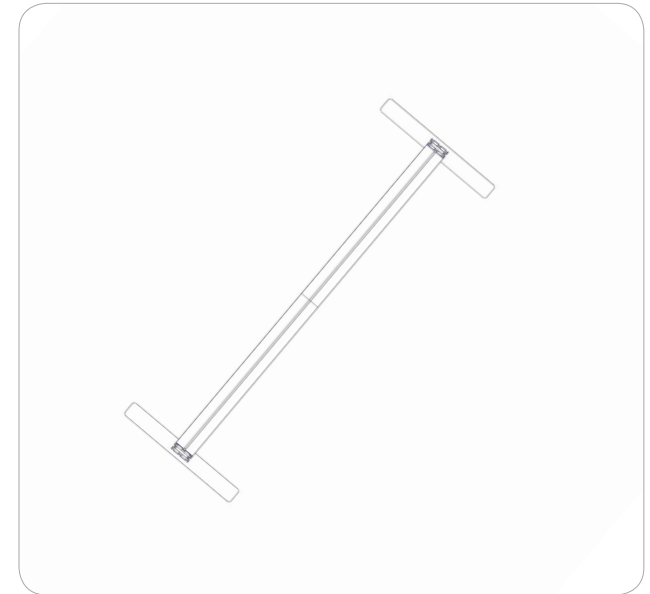
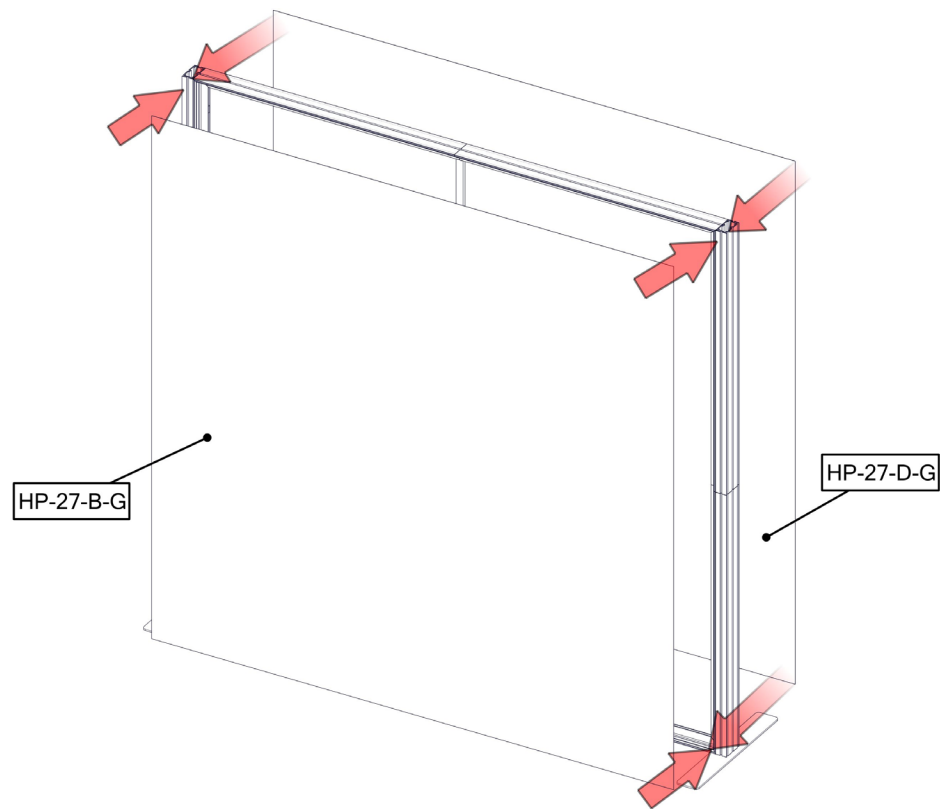

-ATTACH FRONT & REAR GRAPHICS

Exploded Diagram

HP-K-27

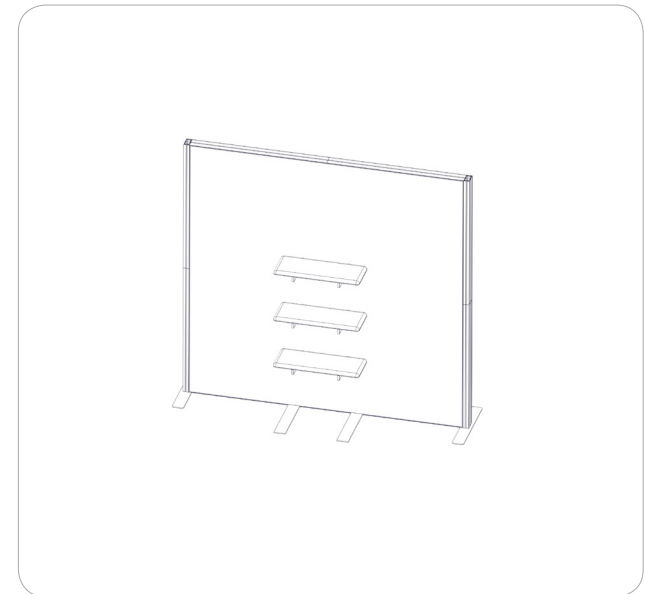
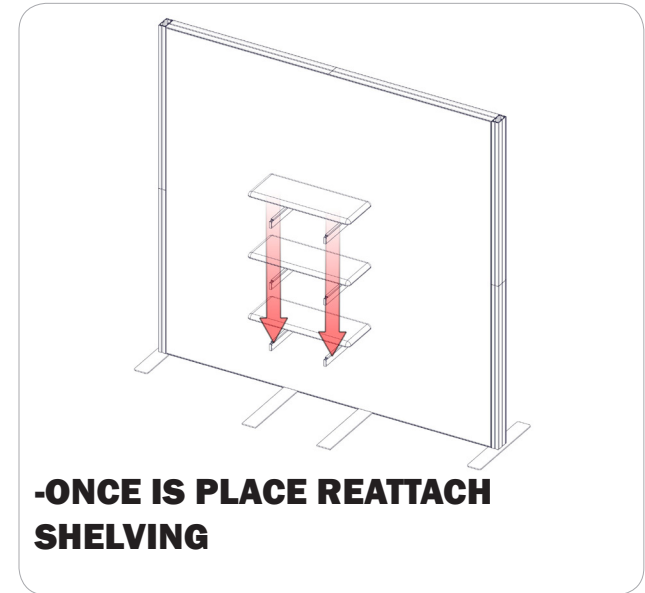

-PLACE PM4S3-MK-SHELF-UNIT

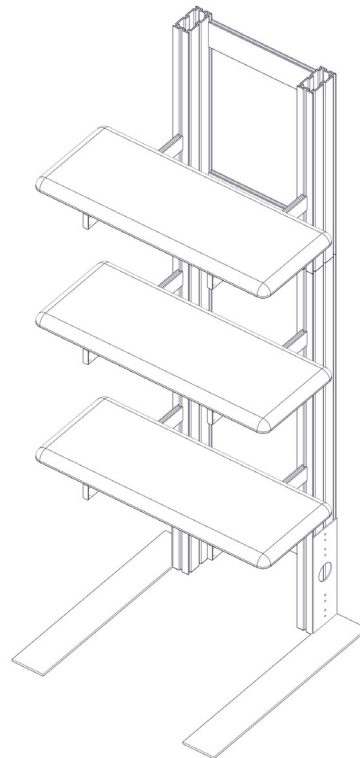

Exploded Diagram

HP-K-27

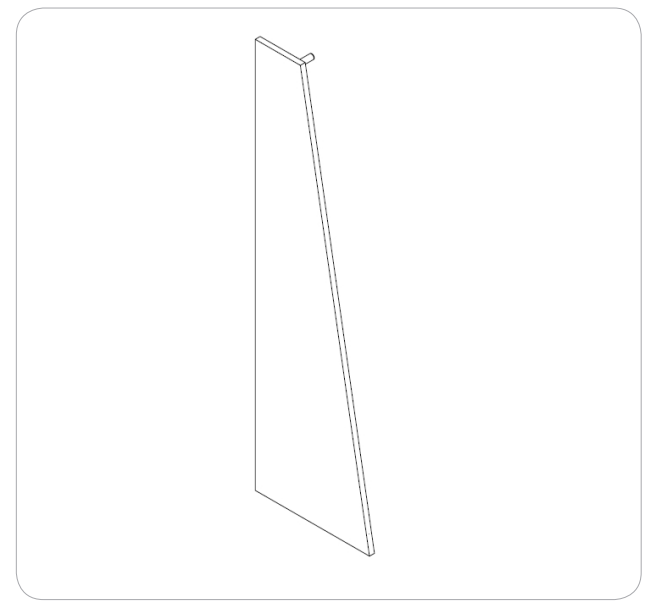
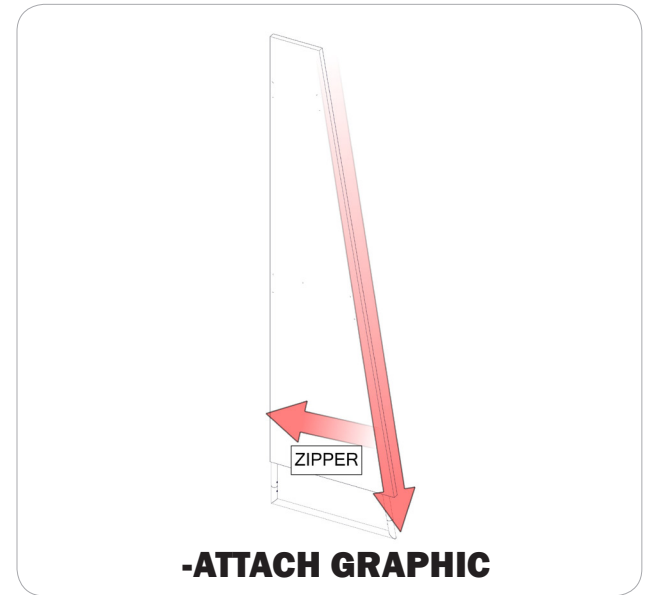
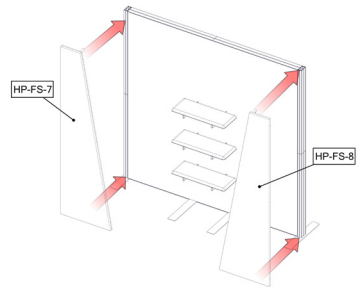
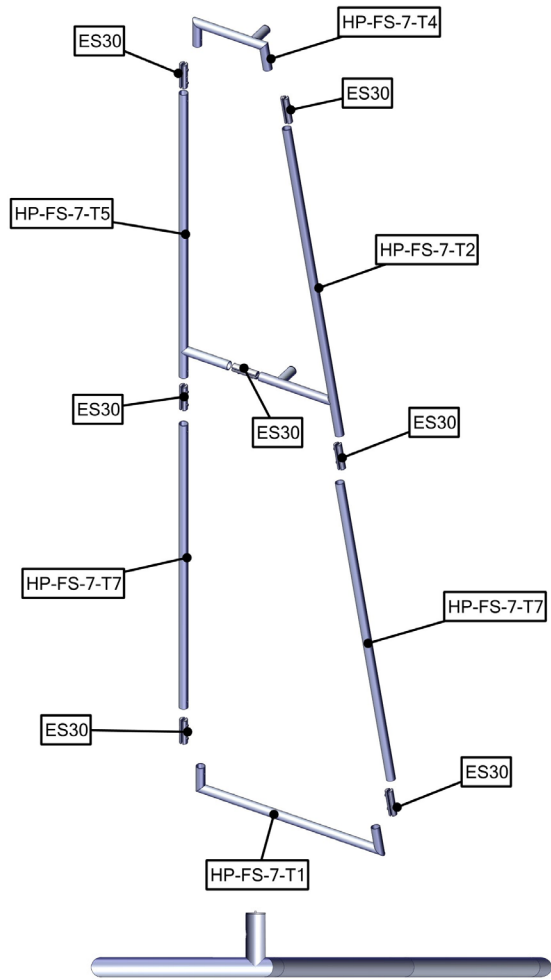

-ASSEMBLE HP-FS-7 FABRIC STRUCTURE

Exploded Diagram

HP-K-27

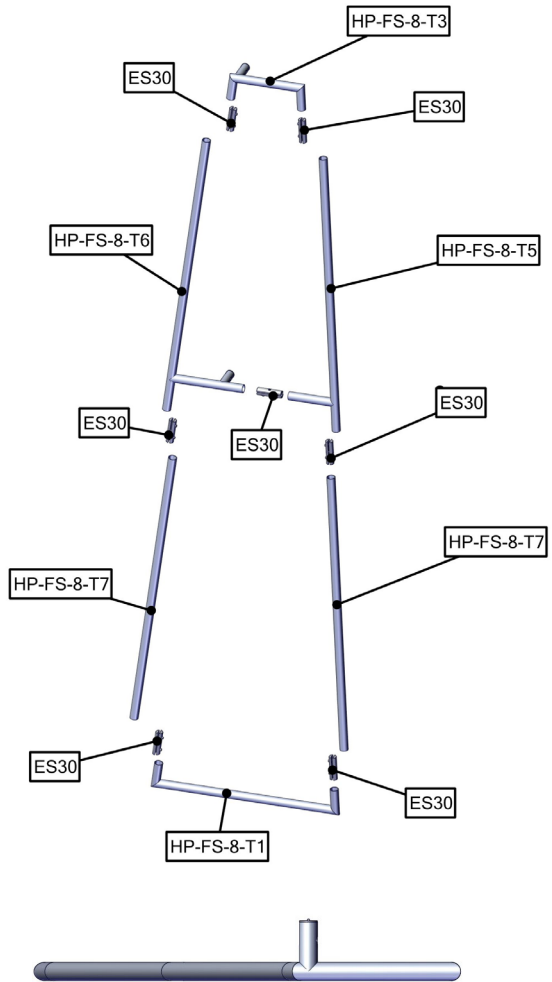

-ASSEMBLE HP-FS-8 FABRIC STRUCTURE

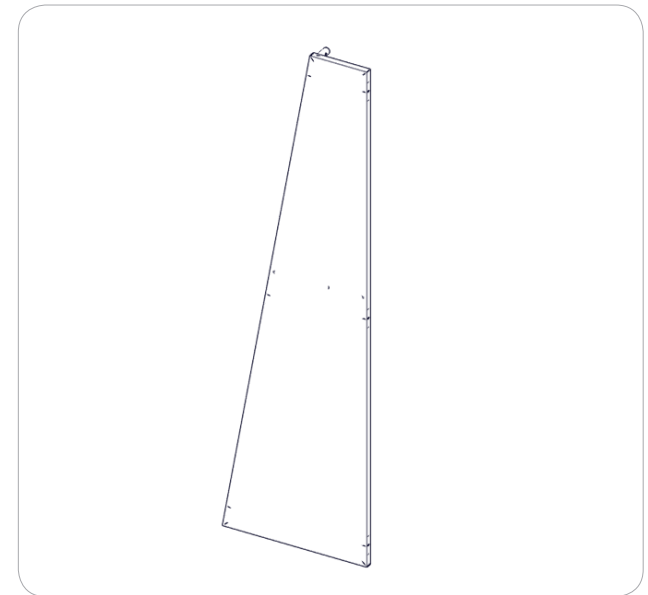
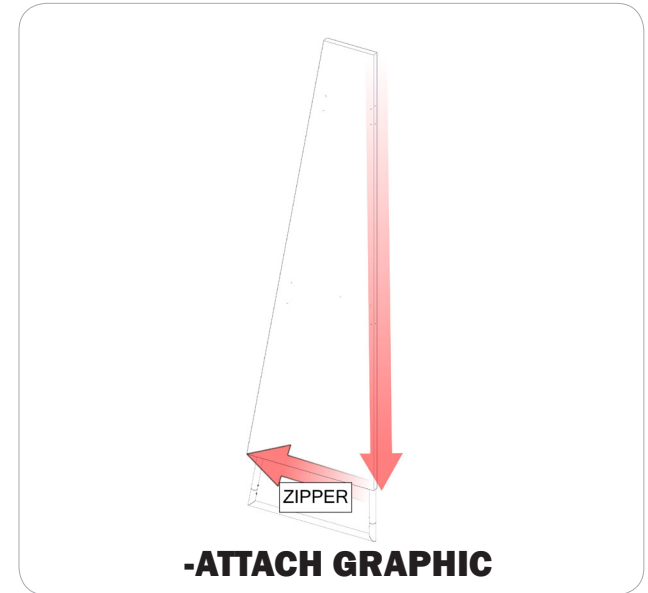
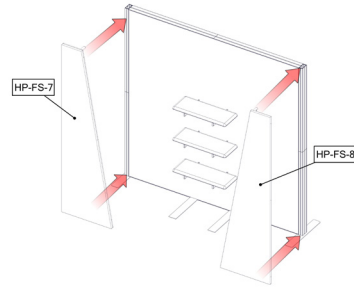

Exploded Diagram

HP-K-27

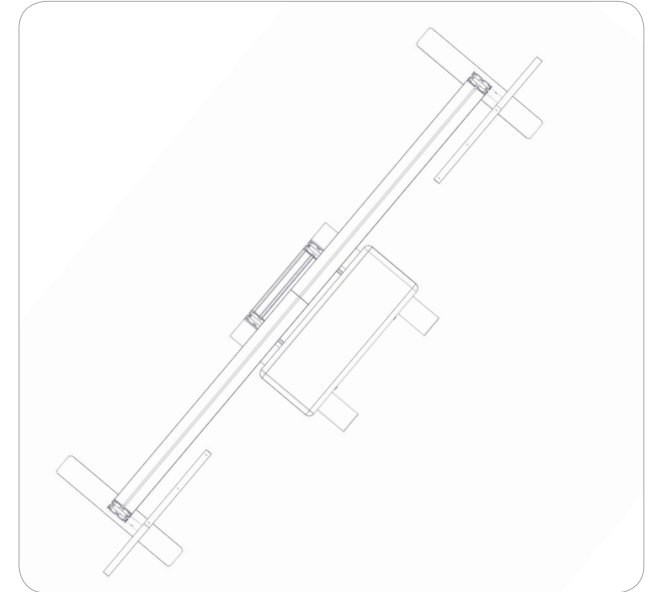
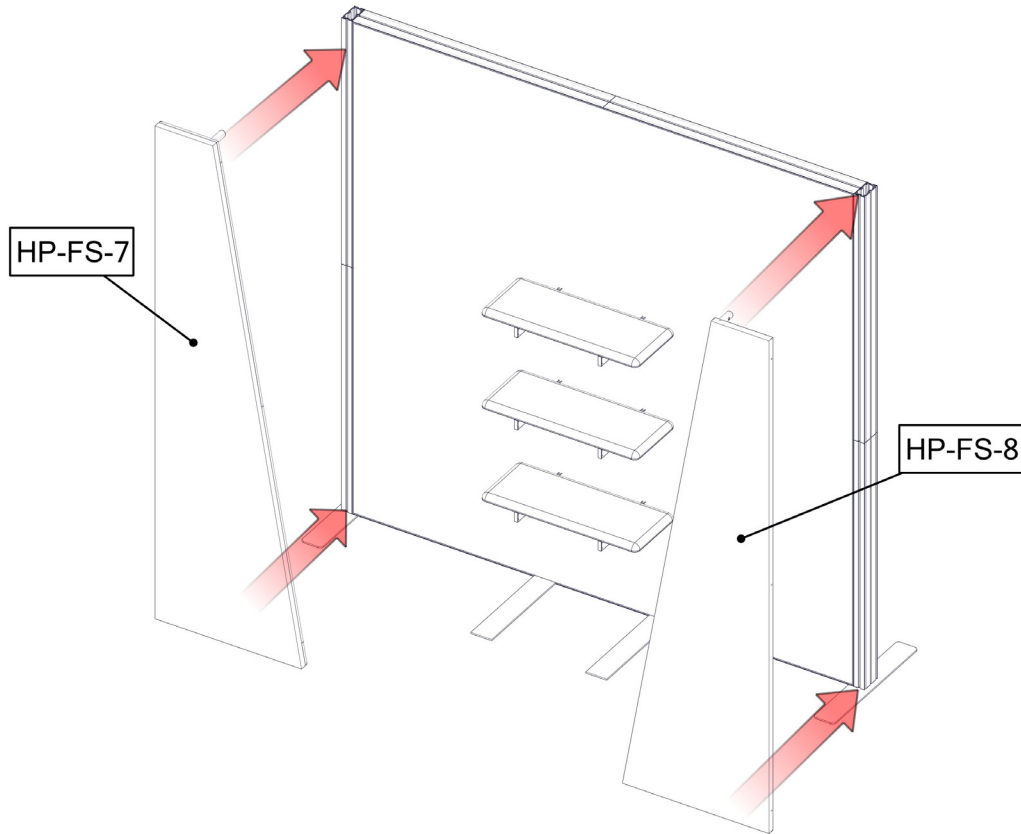

-ASSEMBLE HP-FS-7 & HP-FS-8

Suggested Kit Layout

HP-K-27

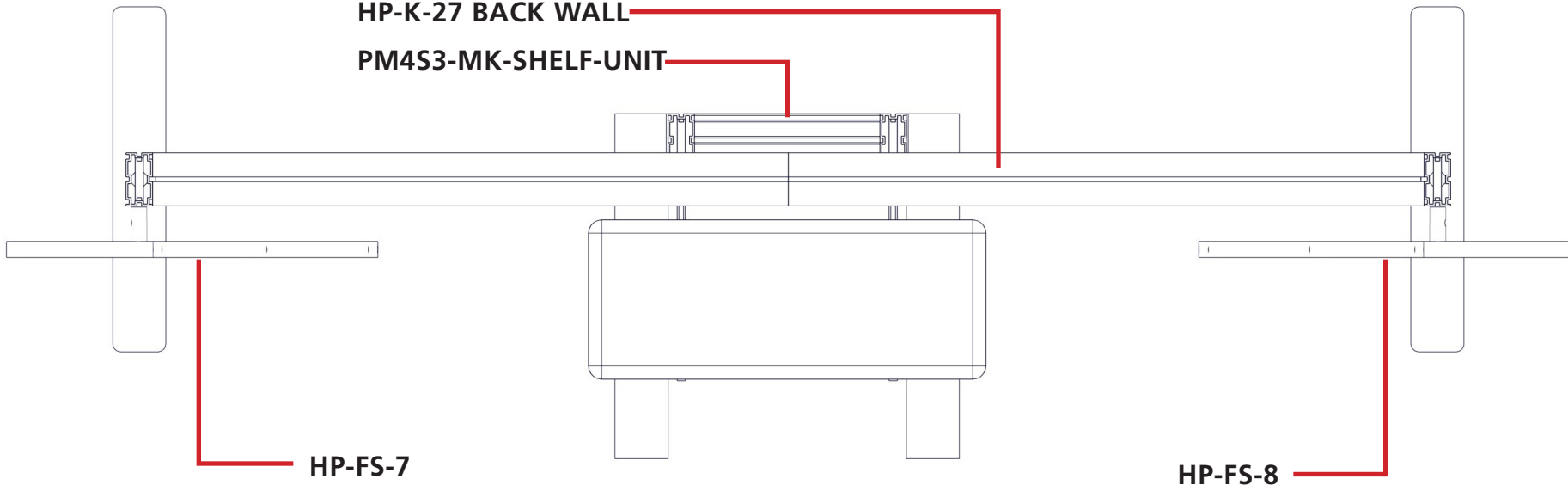

Kit Assembly

Step by Step

Step 1.

Gather the components to build the back wall. Use the Exploded View and the Labeling Diagram for part labels.

Reference Connection Method(s) 1, 2, 9, and 10 for more details.

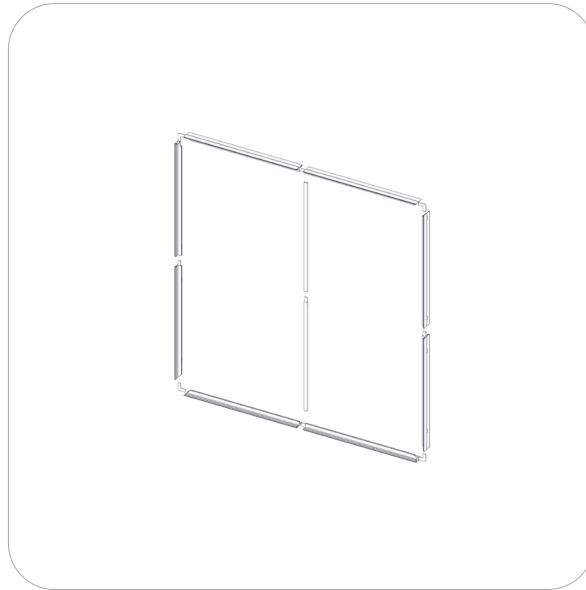

Step 2.

Gather the components to build the side supports. Use the Exploded View and the Labeling Diagram for part labels.

Reference Connection Method(s) 3 and 8 for more details.



Step 3.

Attach front & rear graphics. Use the Exploded View and the Labeling Diagram for part labels.

Reference Connection Method(s) 6 for more details.

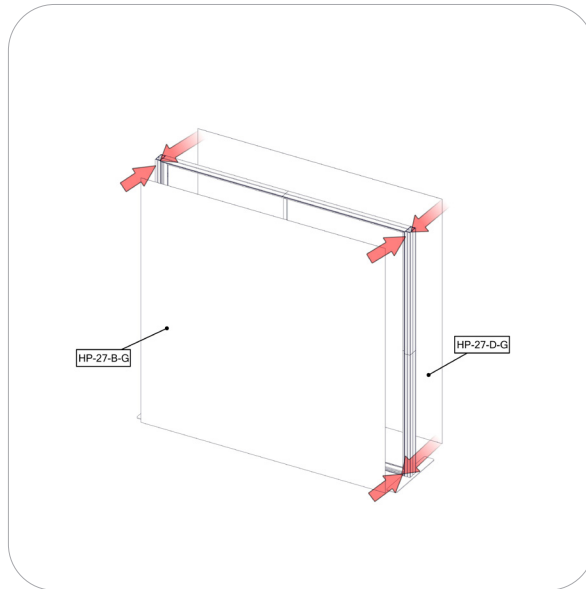

Step 4.

Assemble PM4S3-MK-SHELF-UNIT.

Reference Connection Method(s) Attach detail PDF follows this page on assemble instructions

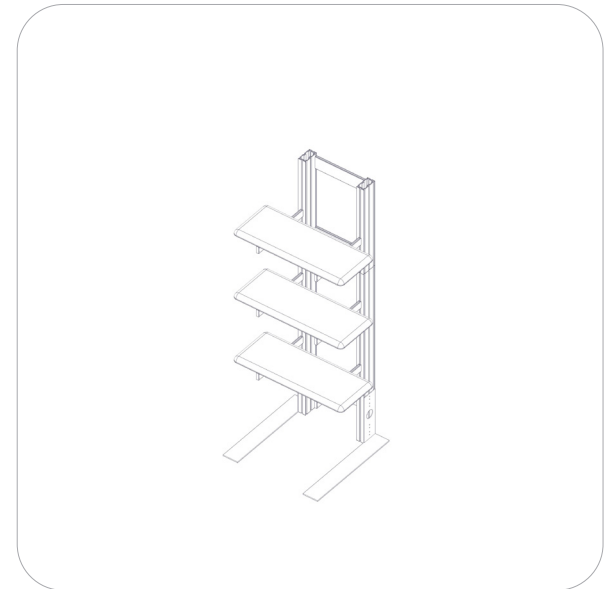

Kit Assembly

Step by Step

Step 5.

Arrange PM4S3 UNIT in desired position. Use the Exploded View and the Labeling Diagram for part labels.

Reference Connection Method(s) Placement see PDF attached for instruction.

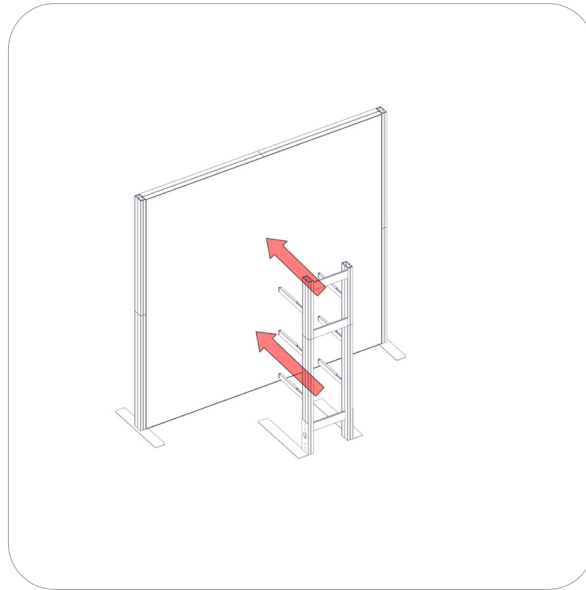
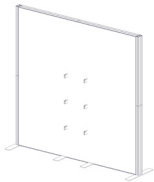

Step 6.

Re-attach Shelves to unit once in position. Use the Exploded View and the Labeling Diagram for part labels.

Reference Connection Method(s) Placement see PDF attached for instruction.

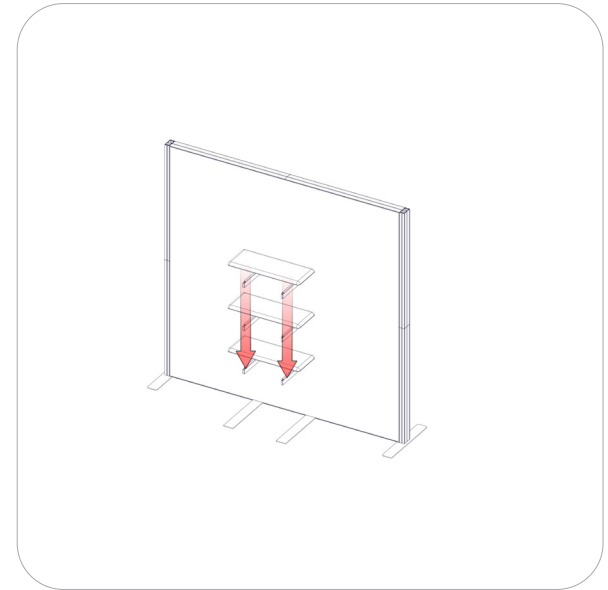
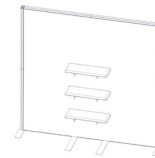

Step 7.

Gather the components to build HP-FS-7. Use the Exploded View and the Labeling Diagram for part labels.

Reference Connection Method(s) 7 for more details.



Step 8.

Gather the components to build HP-FS-8. Use the Exploded View and the Labeling Diagram for part labels.

Reference Connection Method(s) 7 for more details.

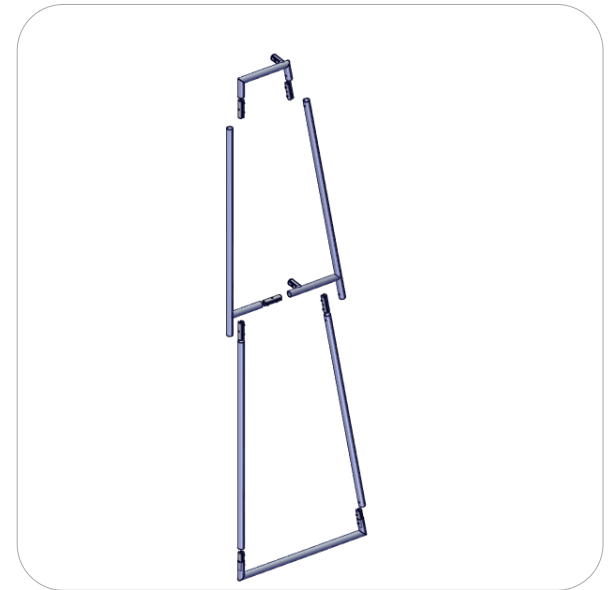

Kit Assembly

Step by Step

Step 9.

Attach graphic to HP-FS-8. Use the Exploded View and the Labeling Diagram for part labels.

Reference Connection Method(s) 9 for more details.

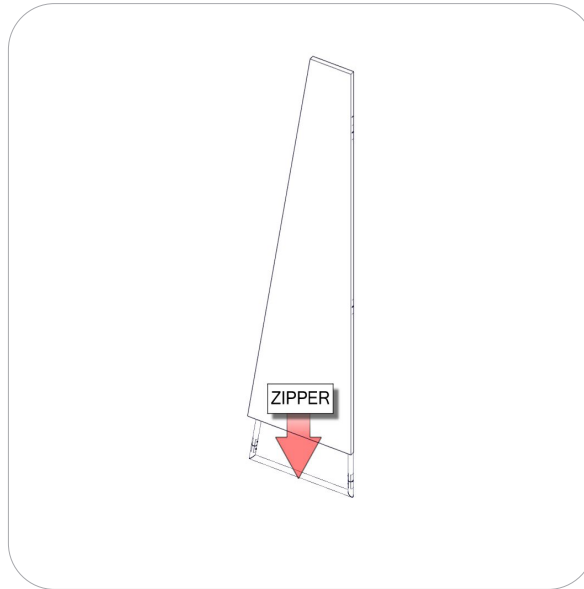

Step 10.

Attach graphic to HP-FS-7. Use the Exploded View and the Labeling Diagram for part labels.

Reference Connection Method(s) 9 for more details.

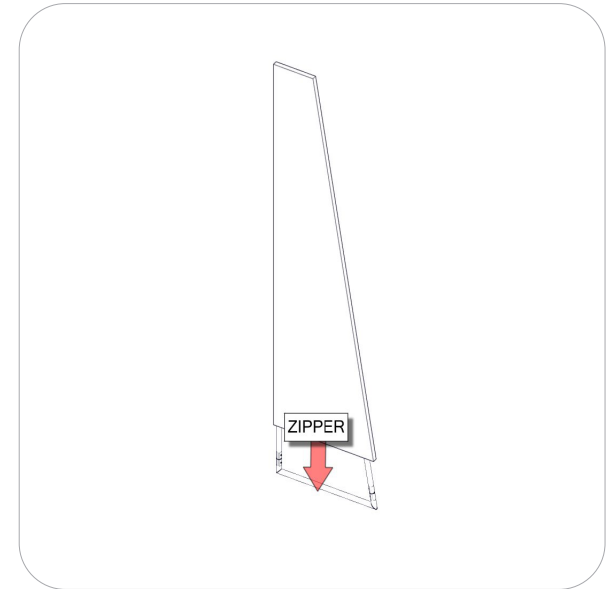

Step 11.

Attach HP-FS-8 & HP-FS-7 to frame. Use the Exploded View and the Labeling Diagram for part labels.

Reference Connection Method(s) 9 for more details.

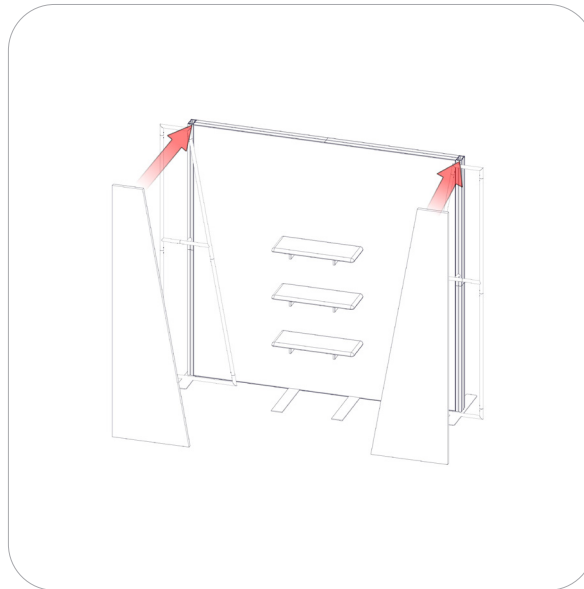
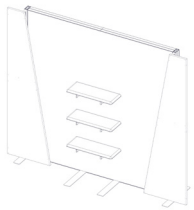

Connection Methods

Connection Method 1: CB9

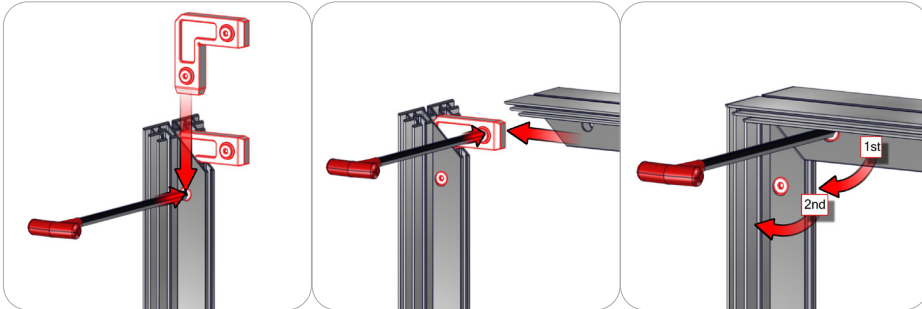

First, insert the corner connector into the extrusion while holding in the lock button with the allen key tool. Second, slide the next extrusion onto the same corner connector while holding in the lock button using the allen key tool. Third, use the allen key tool for locking the corner connector buttons in place. Use the allen key tool to make half turns clock-wise. Do not over tighten the lock buttons.

Connection Method 2: IB2

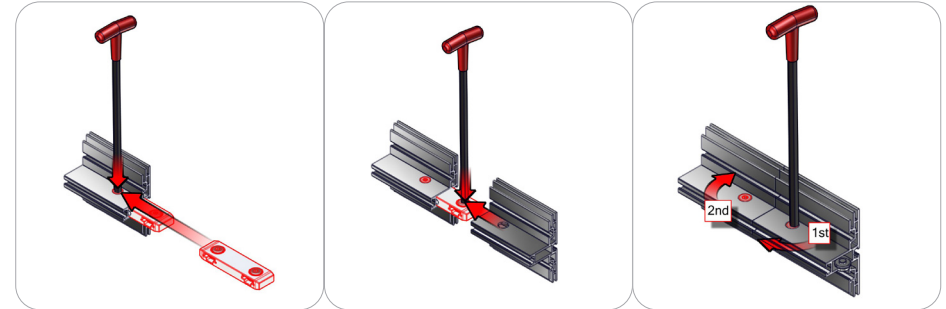

First, insert the in-line connector into the extrusion while holding in the lock button with the allen key tool. Second, slide the next extrusion onto the same in-line connector while holding in the lock button using the allen key tool. Third, use the allen key tool for locking the in-line connector buttons in place. Use the allen key tool to make half turns clock-wise. Do not over tighten the lock buttons.

Connection Method 3: PH2

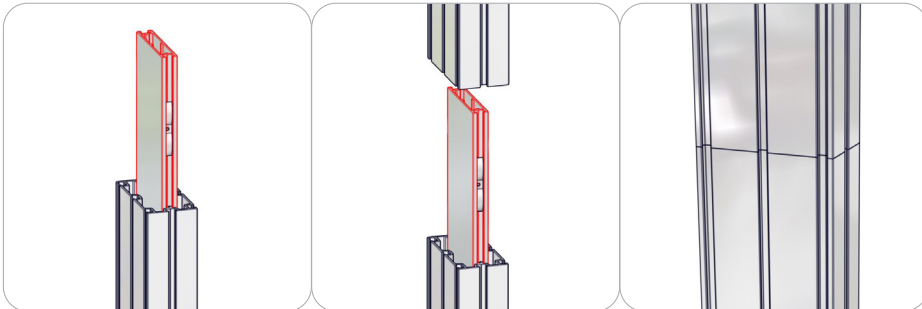

First, slide the PH2 connector into post until rest on the PH2 stop. Second, then slide the top post onto the PH2 connector.

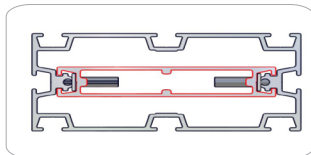

Connection Method 4: CAM LOCK

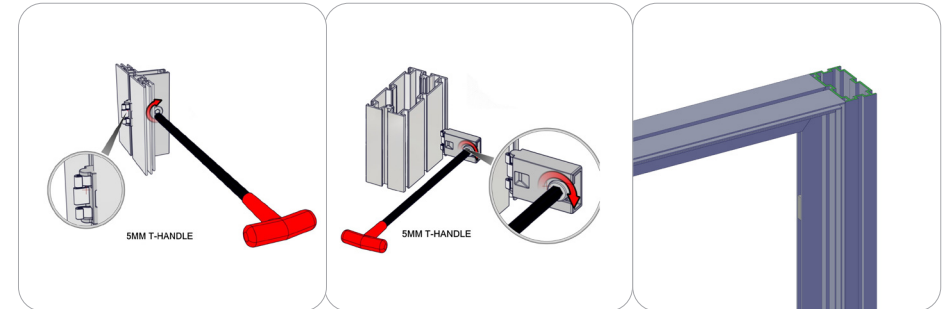

First, with the cam lock disengaged, place the cam lock teeth into the extrusion channel. Second, use the allen key tool to lock it in place. Make half turns clock-wise to engage the cam lock. Do not over tighten the lock buttons.

Connection Methods

Connection Method 5: LN114-S2-650

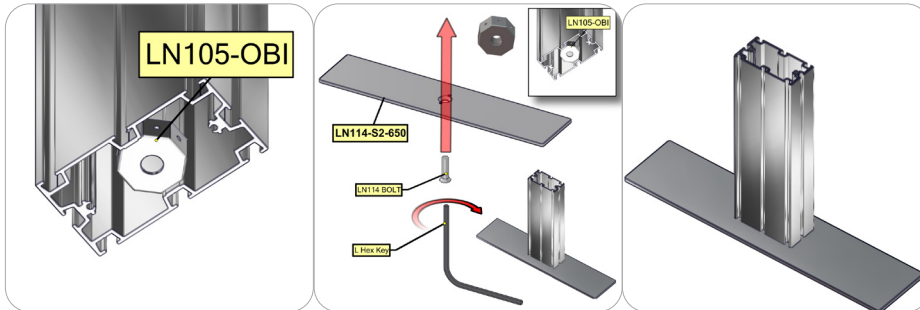

First, line up base plate screw hole with PM4S3 inside nut. Second, insert screw tighten til plate is snug or no movement. Do not over tight this can damage the extrusion or inside nut.

Connection Method 6: Graphic Application

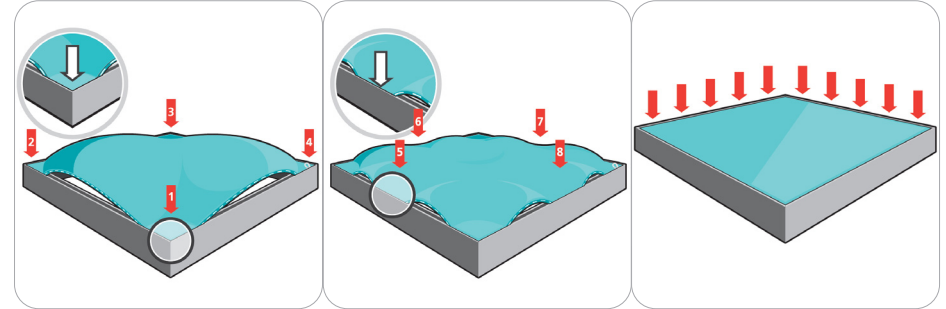

First, insert the silicone edge frame corners into the frame graphic channel (points 1 through 4). Second, insert the silicone edge frame sides into the frame graphic channel (points 5 through 8). Third, push the remaining silicone edge fabric into the frame graphic channel. Similar setup is recommended for the opaque liner. To remove these panels, simply pull the loop tag sewn near a corner.

Connection Method 7: ES30

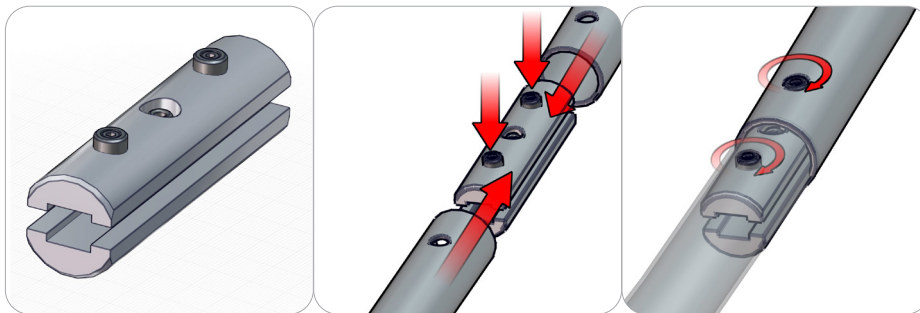

First, compress the unlocked connector and slide into the tube lock access hole. Lock both screws carefully using your allen key tool. Be sure to lock securely, but do not over tighten. For snap button connections

Connection Method 8: CAM LOCK

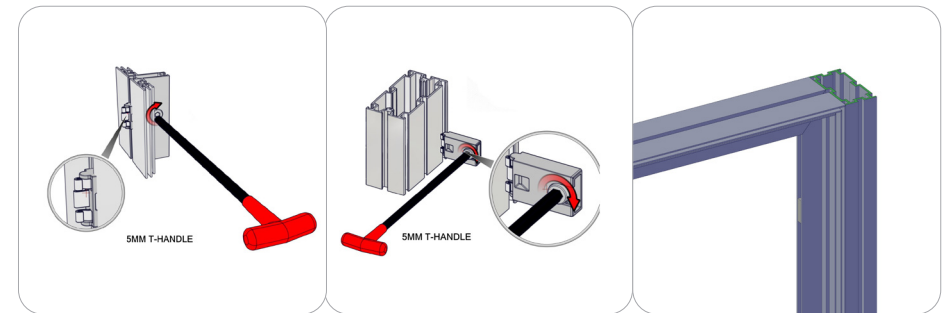

First, with the cam lock disengaged, place the cam lock teeth into the extrusion channel. Second, use the allen key tool to lock it in place. Make half turns clock-wise to engage the cam lock. Do not over tighten the lock buttons.

Connection Methods

Connection Method 9: PH1

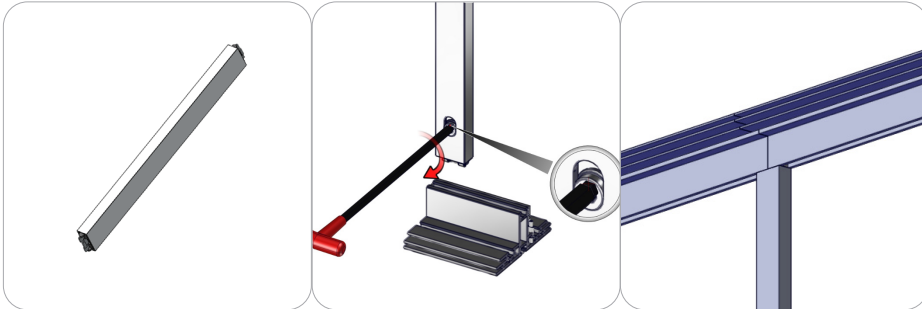

First, with the cam lock disengaged, place the cam lock teeth into the extrusion channel. Second, use the allen key tool to lock it in place. Make half turns clock-wise to engage the cam lock. Do not over tighten the lock buttons.

Connection Method 10: IB2/PH1 Application

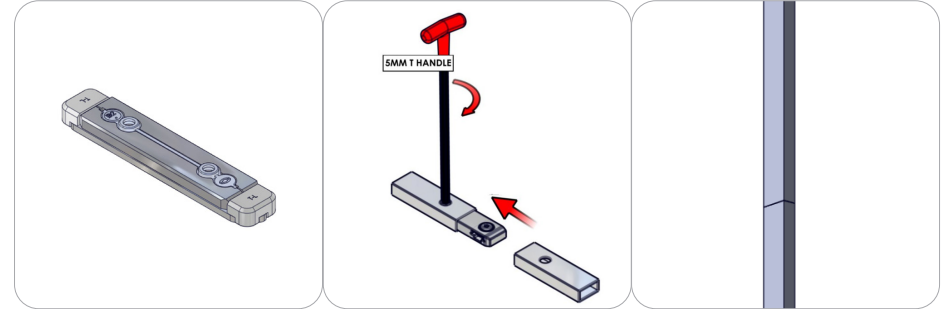

First, insert the silicone edge frame corners into the frame graphic channel (points 1 through 4). Second, insert the silicone edge frame sides into the frame graphic channel (points 5 through 8). Third, push the remaining silicone edge fabric into the frame graphic channel. Similar setup is recommended for the opaque liner. To remove these panels, simply pull the loop tag sewn near a corner.

Connection Method 11: ADT-CAM-SM

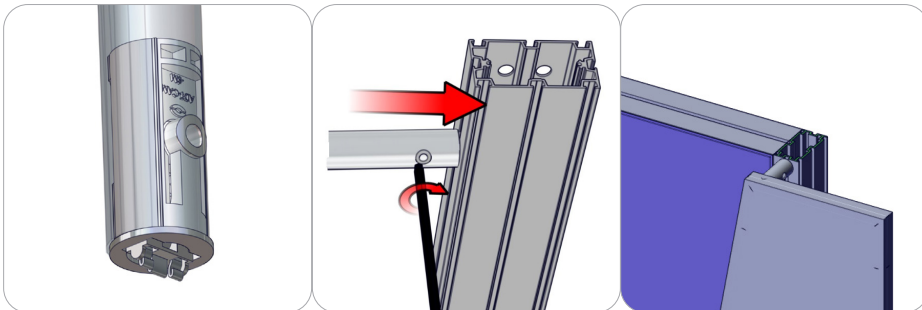

ADT-CAM-SM is already embedded inside tube. First, with the cam lock disengaged, place the cam lock teeth into the extrusion channel. Second, use the allen key tool to lock it in place. Make half turns clock-wise to engage the cam lock. Do not over tighten the lock buttons.

Freestanding Monitor Kiosk

PM4S3-MK-M
PM4S3-MK-L

PM4S3-MK-M-MSHELF
PM4S3-MK-L-MSHELF

PM4S3-MK-SHELF-UNIT

The Freestanding Monitor Kiosk is a superior multimedia display that can be used for multiple applications, as well as in trade show exhibits and for events. Kiosks include monitor mounts to support a medium or large size TV, and a corresponding medium or large shelf may be added. Monitor mounts support TV's up to 40 lbs and 32" - 70" in size, and can be adjusted to the perfect height; an included shelf can hold up to 15 lbs. The Shelf Unit is a great addition that proudly displays small products. Install the Freestanding line behind a fabric backwall for a truly impressive display.

Freestanding Monitor Kiosk



PM4S3-MK-M
PM4S3-MK-L

Freestanding Monitor Kiosk with Shelf



PM4S3-MK-M-MSHELF
PM4S3-MK-L-MSHELF

Freestanding Shelf Unit



PM4S3-MK-SHELF-UNIT

features and benefits:

- Premium aluminum extrusion frames with cam lock and tension glide assembly
- Easy to store and ship
- Quick to set up
- Weighted feet for added stability
- Kits may include: a medium or large monitor mount, shelf, or combination
- Choice of medium or large monitor mount options. (Freestanding Monitor Kiosk with Shelf or Freestanding Shelf)
- Lifetime limited hardware warranty against manufacturer defects

dimensions:

Hardware

Assembled unit (no shelf):
25.59" w x 70.98" h x 25.59" d
650mm(w) x 1803mm(h) x 650mm(d)

Assembled unit (with shelf):
29.53" w x 70.98" h x 25.59" d
751mm(w) x 1803mm(h) x 650mm(d)

Approximate weight:
(excludes cases & monitor mount)

40 lbs / 19 kg

Add 10 lbs / 5 kg for each shelf

Shipping

Packing case(s):
1 OCE Case

Shipping dimensions:
OCE: Expandable case length (l) may vary
40" - 66" l x 18" h x 18" d
1016mm-1677mm(l) x 458mm(h) x 458mm(d)

Approximate total shipping weight:

Monitor Kiosk:
(Case & monitor mount)

Medium
83 lbs / 38 kg

Large
85 lbs / 39 kg

additional information:

-Medium monitor mount can hold 37-70" monitor/ max weight 40 lbs

-Large monitor mount can hold 40"-65" monitor/ max weight 40 lbs

-Monitor not included

-Shelf can hold suggested max weight: 15 lbs

-If shipping with backwall kit cases may vary

Monitor Kiosk with Shelf:
(Case, monitor mount, & shelf)

Medium
93 lbs / 43 kg

Large
95 lbs / 44 kg

Shelf Unit:
(Case & shelves)
116 lbs / 53 kg

We are continually improving and modifying our product range and reserve the right to vary the specifications without prior notice. All dimensions and weights quoted are approximate and we accept no responsibility for variance. E&OE. See Graphic Templates for graphic bleed specifications.

Included In Your Freestanding Monitor Kiosk

Tools, Components, Connectors & Extrusions



5MM ALLEN-T x1

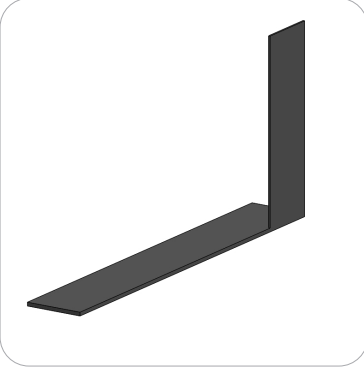

PM4S3-MM-FOOT-L x1



PM4S3-MM-FOOT-R x1



LN100 x6

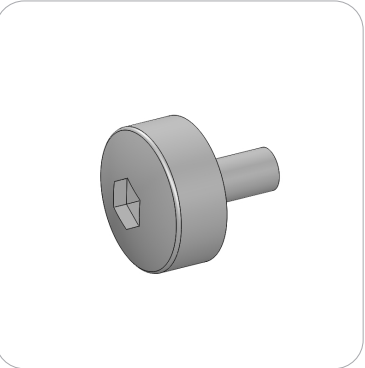

M5 THUMBSCREW x8

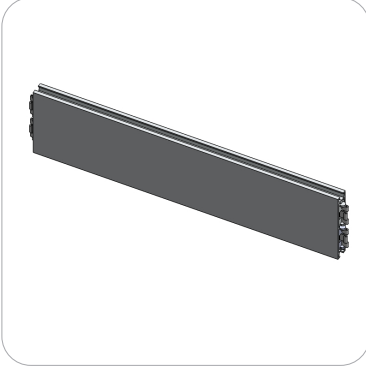

PH2-350-L-L x3

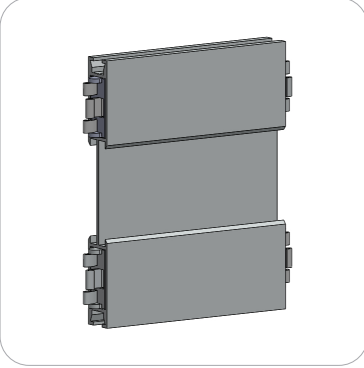

PH5-100-L-L x2

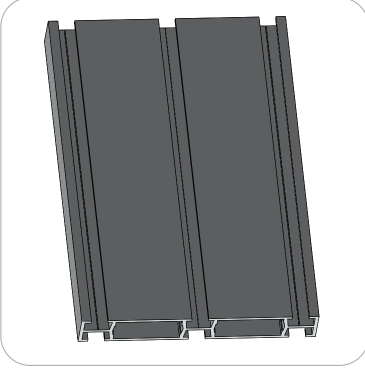

PM4S4-150 x2

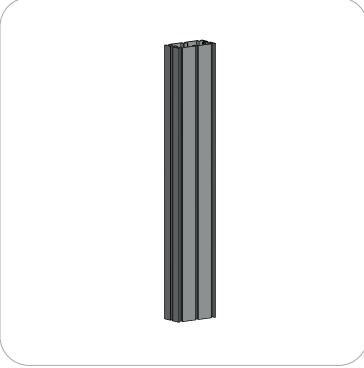

PM4S3-600-A165-A165 x2



PM4S3-1200-A165-A165 x2

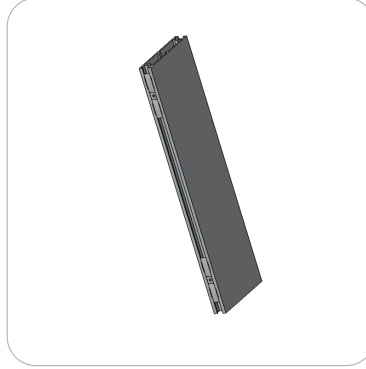

PH2-300-TG x2



EXT-M-MB (or) EXT-LG-MB x1
Fastening Hardware Included



CBE-50 x2



Included In Your Freestanding Monitor Kiosk with Shelf

Tools, Components, Connectors & Extrusions



5MM ALLEN-T x1

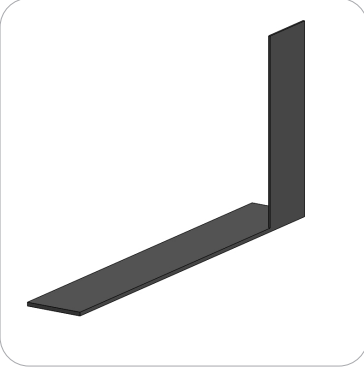

PM4S3-MM-FOOT-L x1



PM4S3-MM-FOOT-R x1



LN100 x6

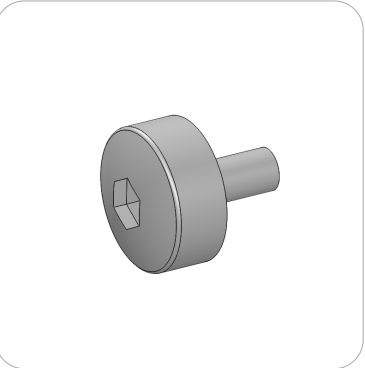

M5 THUMBSCREW x8



PH2-350-L-L x3

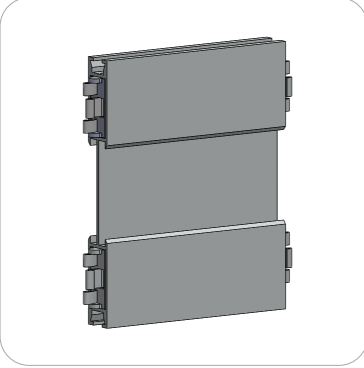

PH5-100-L-L x2

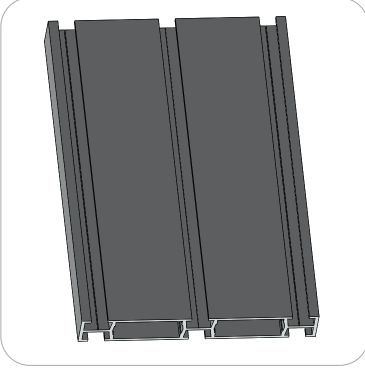

PM4S4-150 x2

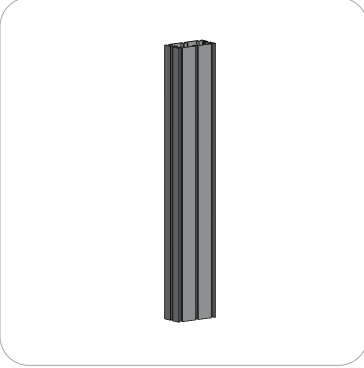

PM4S3-600-A165-A165 x2



PM4S3-1200-A165-A165 x2

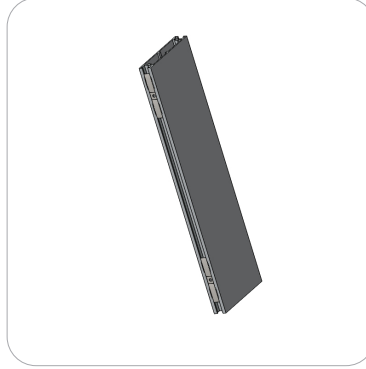

PH2-300-TG x2



EXT-M-MB (or) EXT-LG-MB x1
Fastening Hardware Included



CBE-50 x4



Included In Your Freestanding Monitor Kiosk with Shelf

Components, Connectors & Extrusions

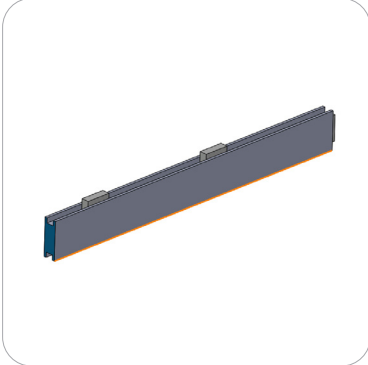

PH-400-L-SIDE-MK x2

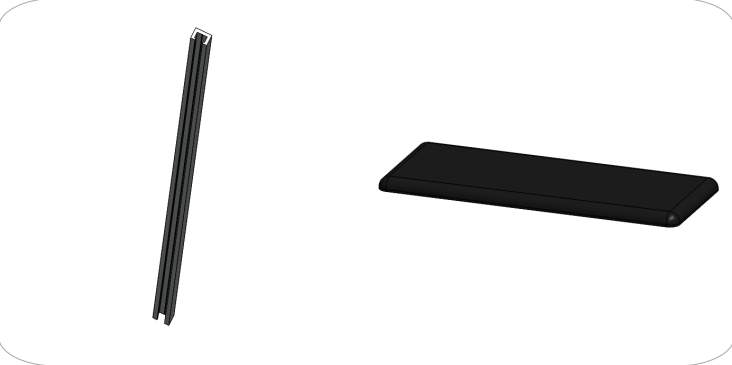

PE-1200 x2
*will ship preattached to shelf



CT21-MK-SHELF x1



LN605-EN x2



Included In Your Freestanding Shelf

Tools, Components, Connectors & Extrusions



5MM ALLEN-T x1

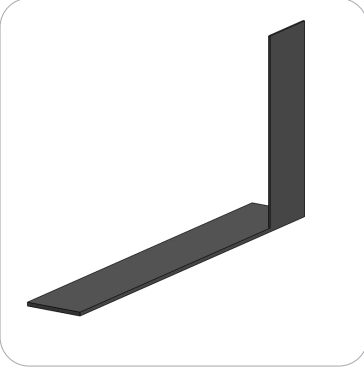

PM4S3-MM-FOOT-L x1



PM4S3-MM-FOOT-R x1



LN100 x6

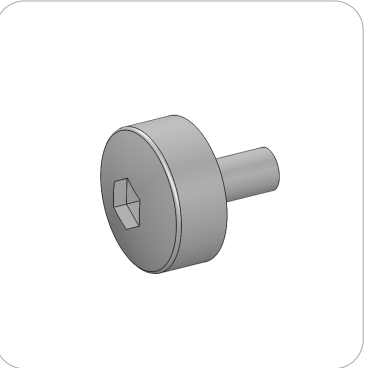

M5 THUMBSCREW x8



PH2-350-L-L x3

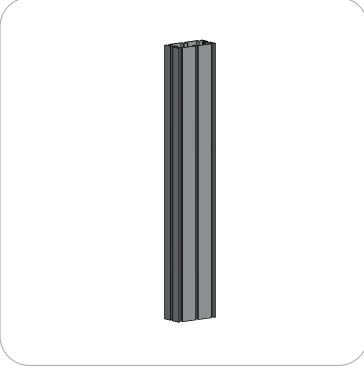

PM4S3-600-A165-A165 x2



PM4S3-1200-A165-A165 x2



PH2-300-TG x2

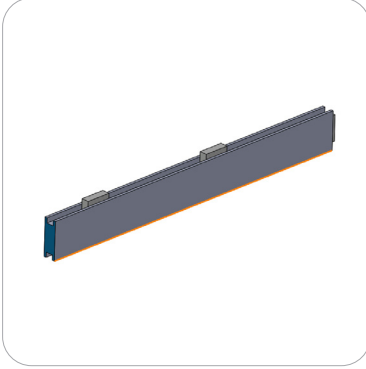

PH-400-L-SIDE-MK x6



PE-1200 x6
*will ship preattached to shelf



CT21-MK-SHELF x3



LN605-EN x6



Exploded View

PM4S3-MK-M PM4S3-MK-L

Please note:
This is the kiosk frame build for
either medium or large kit.

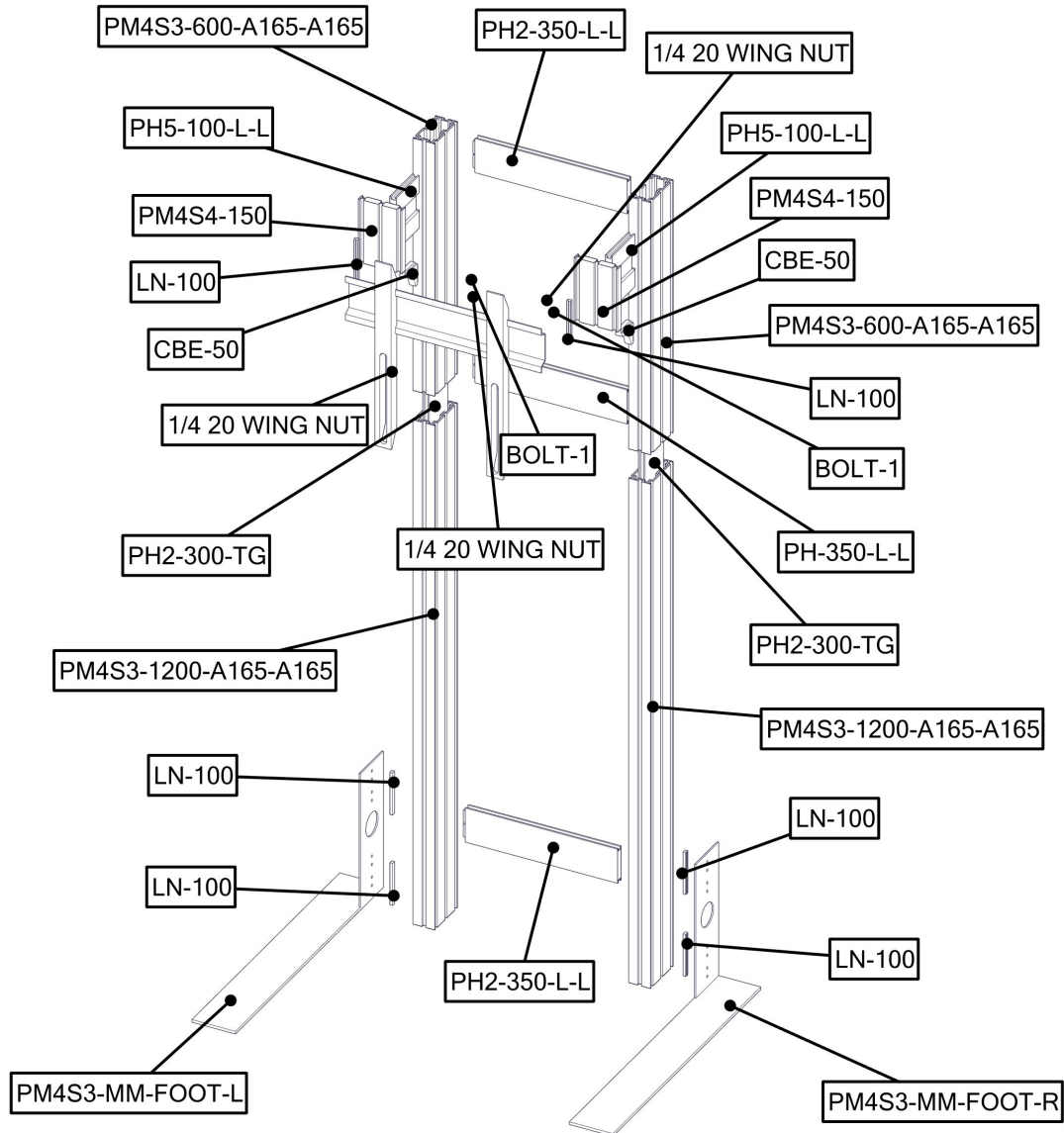

Exploded View

PM4S3-MK-M-MSHELF PM4S3-MK-L-MSHELF

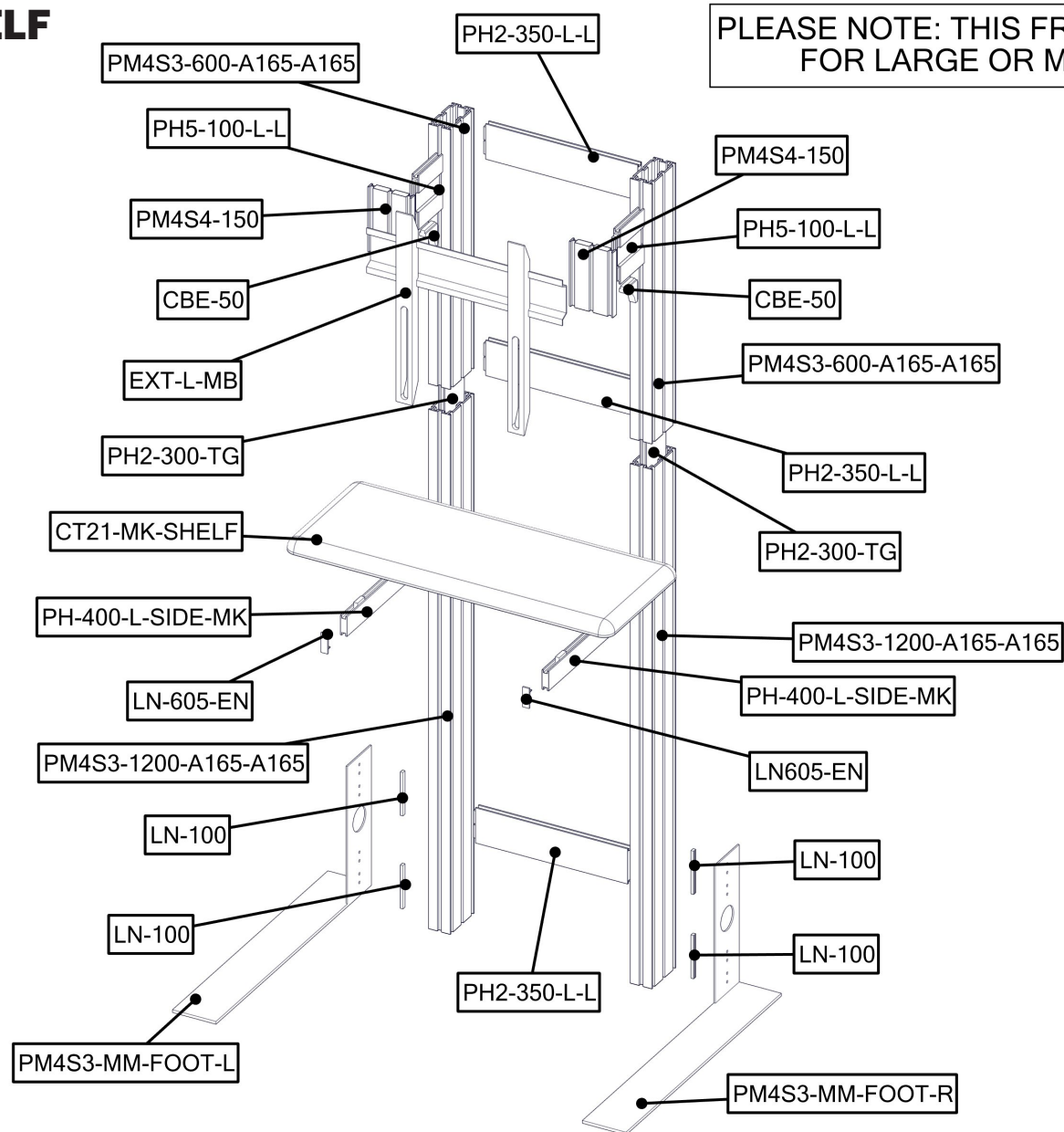

Exploded View

PM4S3-MK-SHELF-UNIT

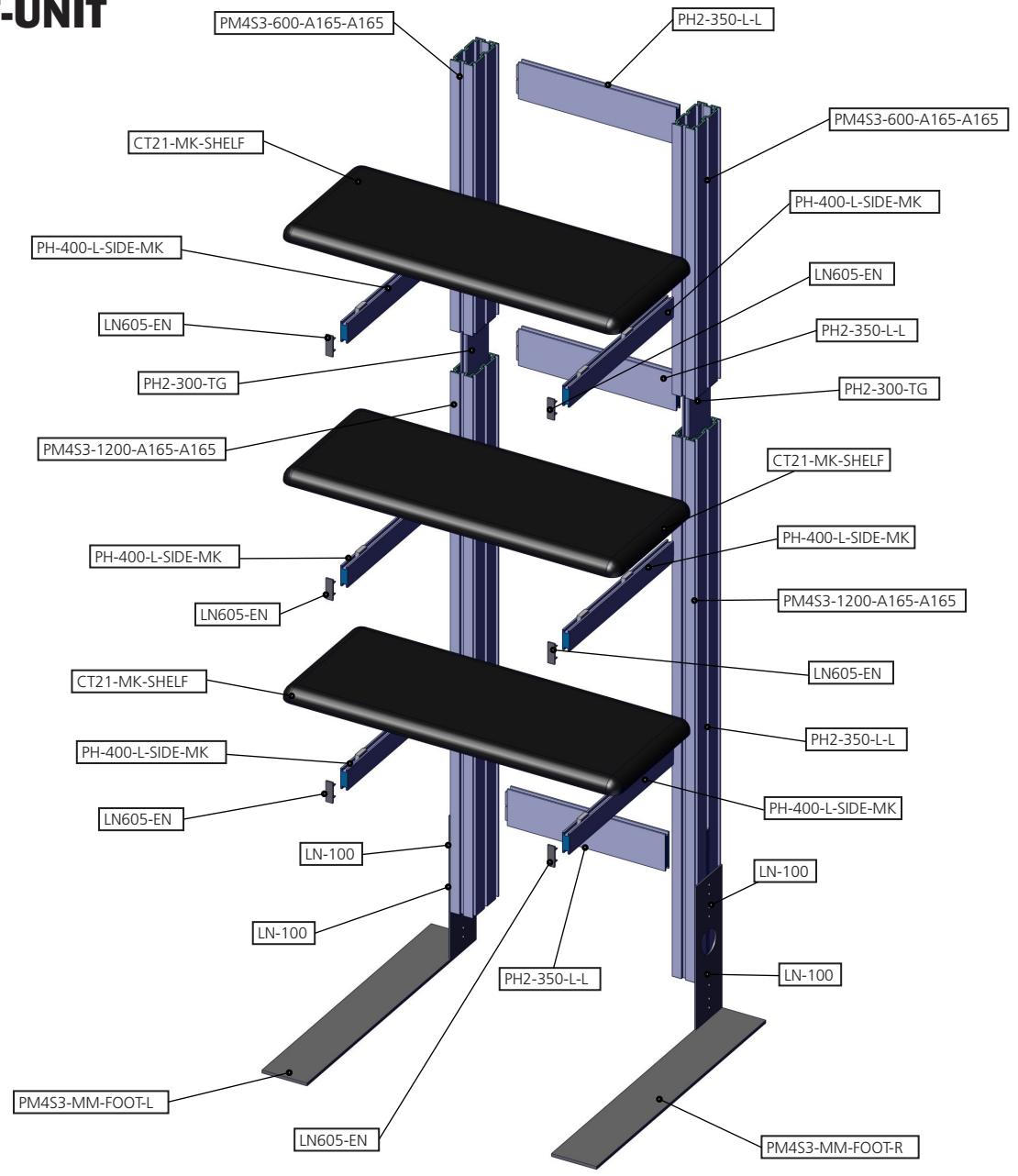

Kit Assembly

Step by Step

Step 1.

Reference the image to the right. Locate the coded extrusions. Slide the PH2-300-TG connector into one end of the PM4S3-1200-A165-A165 so that it goes as deep as the internal pins. Connect the PM4S3-600-A165-A165 by sliding it over the PH2-300-TG. Repeat for this step for the second vertical.

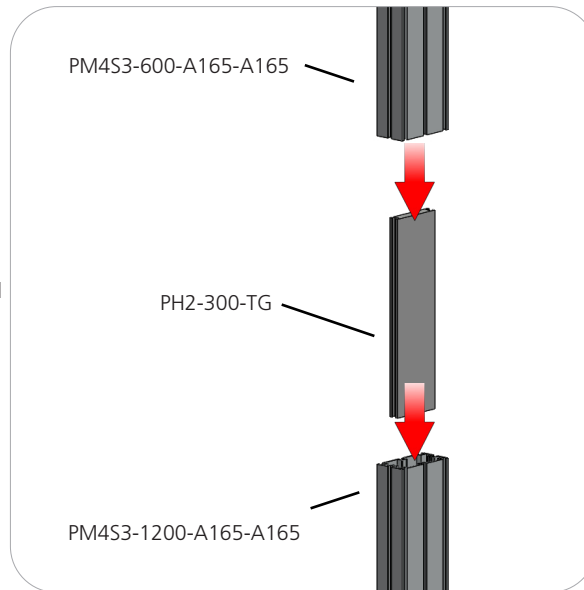

Step 2.

Collect your extrusions and handtool. Using the provided handtool, lock the extrusions into the back channel of the three channel PM4S3 faces as shown in the image below. Be sure the locks face toward the back of the assembly and do not over tighten.

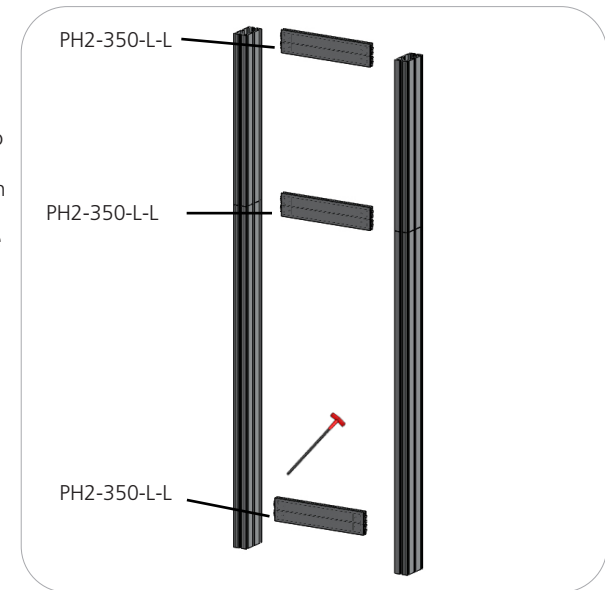
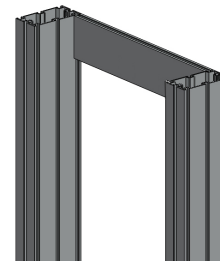

Step 3.

Locate the M5 thumbscrews, LN100s, and the PM4S3-MM stabilizing bases. Slide the LN100s into the middle channel of the PM4S3. Hand screw the M5 thumbscrews through the base holes and into the LN100 holes. Use the handtool to securely fasten the M5 Thumbscrews. Do not over tighten.

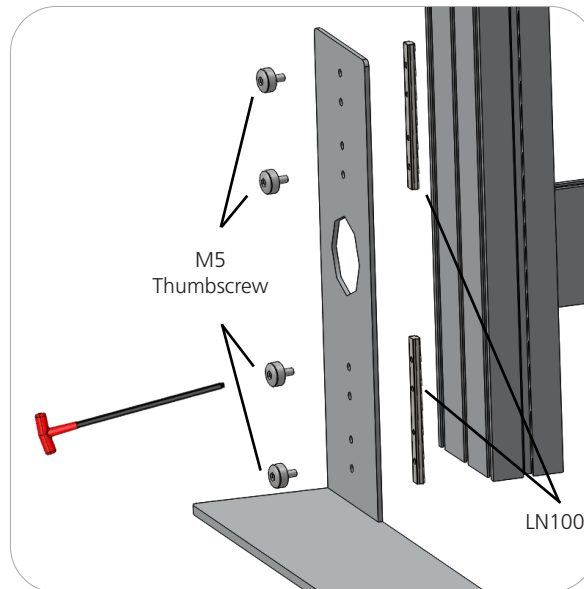

STOP

Orbus recommends that you move your kiosk(s) in place before continuing on with the rest of assembly.

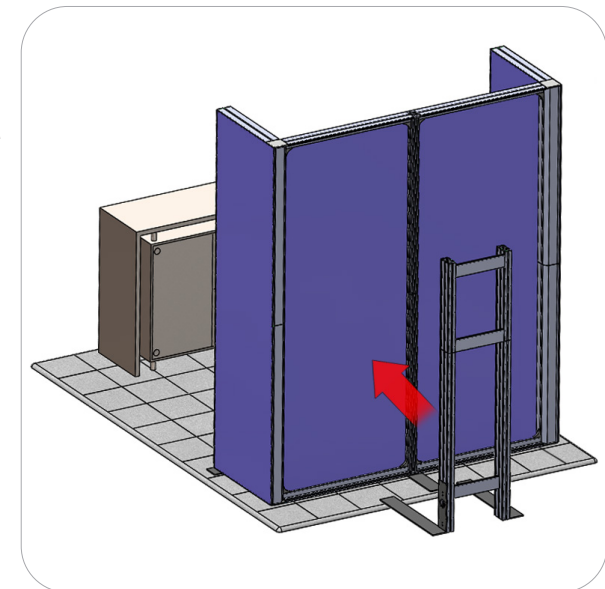

Kit Assembly

Step by Step - Monitor Mount

Step 4.

This step is for kiosks with monitor mounts. Skip to step 7 for shelf kiosks.

Measure from the ground to the center of the hole in your main kit's graphic. Lock the center of your PH5-100-L-L into the PM4S3 stacks at the dimension height of the graphic hole, ADD CBE-50 for support under PH5. Do not over tighten.

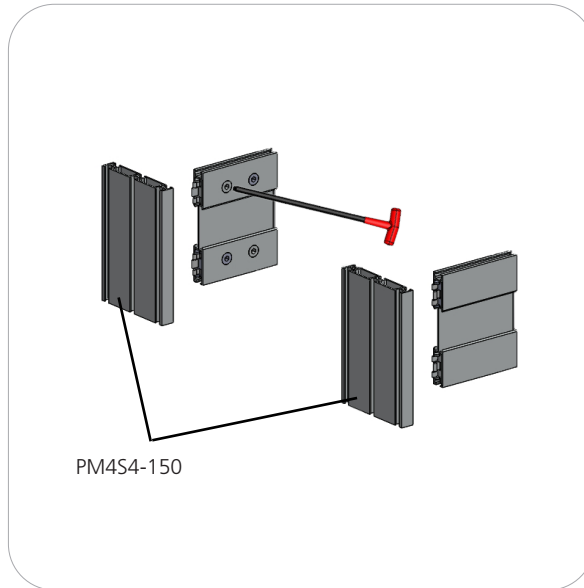
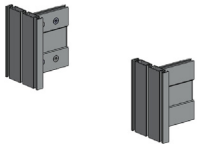

Step 5.

NOTE: Your main backwall assembly must be completed with graphics before completing this step of the monitor kit.

Lock your PM4S4-150 to the ends of the PH5-100-L-L. Do not over tighten.

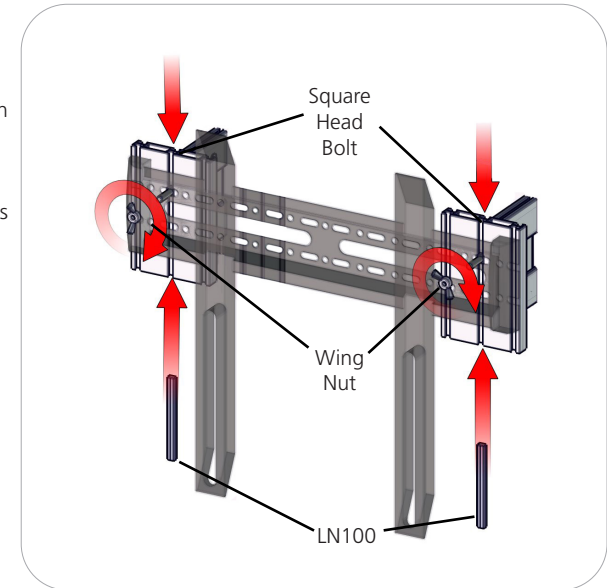
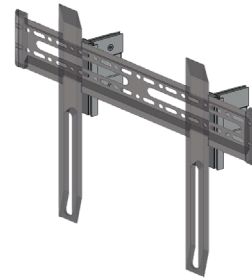

Step 6.

Set your monitor stand so that the extrusion arms fit through the graphic hole. Use the provided fastening hardware to complete your monitor stand. Slide the LN100 into the bottom center channel of the PM4S4-150. Next, slide the Square Head Bolt into the top center channel of the PM4S4-150. Apply the monitor bracket and spacer washer before fastening with the wingnut. Monitor mount may vary depending on size. Monitor not included.

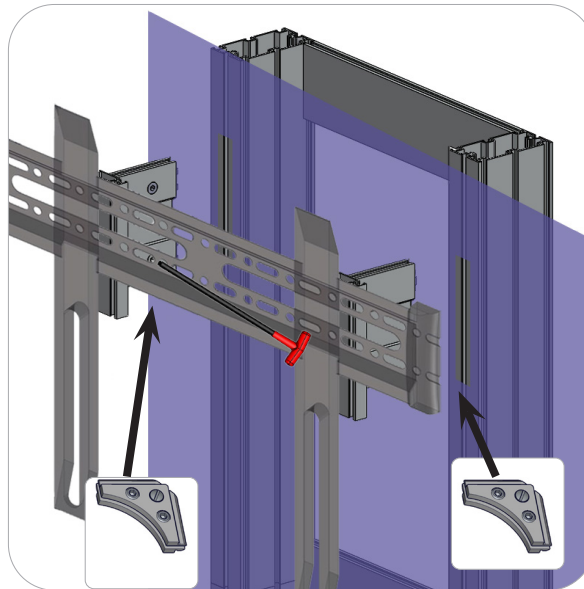

**ATTACH CBE-50 UNDER
PH5 FOR SUPPORT**

Kit Assembly

Step by Step - Shelf

Step 7.

Insert the LN605-EN end caps. Lock the CT21-MK-SHELF to the PH-400-L-SIDE-MK. Do not over tighten.

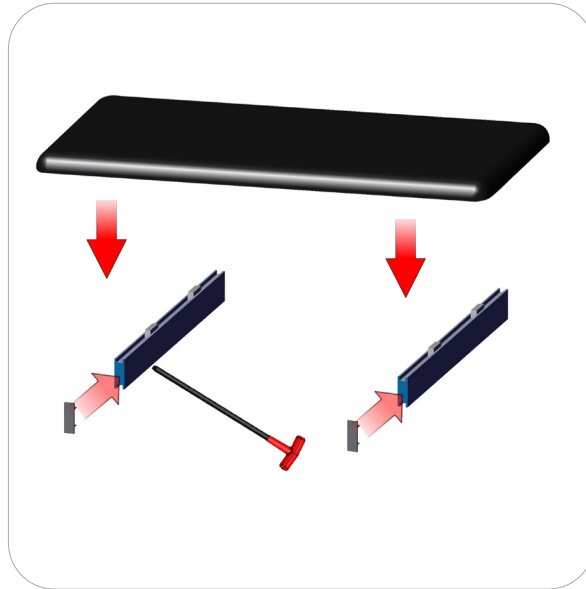

Step 8.

Lock your PH-400-L-SIDE-MK into the PM453 stacks at the desired dimension height. Do not over tighten.

Refer to the attached supplemental sheet for details on shelf height(s).

Setup is complete.

Repeat steps 7 and 8 twice more for Shelf Unit.



Freestanding Display Shelf

PM4S3-MK-SHELF

Freestanding display shelves are easily attached to your assembled kiosk for displaying promotional materials. This shelf can be added to a Freestanding Monitor Kiosk order.

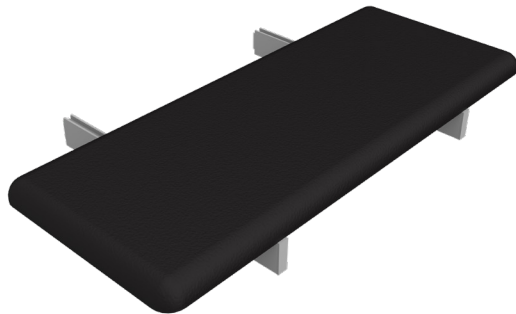

features and benefits:

- Premium aluminum extrusion frames with cam lock and tension glide assembly
- Easy to store and ship
- Quick to set up
- Lifetime limited hardware warranty against manufacturer defects
- Great for display opportunities

dimensions:

Hardware

Assembled unit:
Medium or Large

29.53" w x 6.35" h x 15.87" d
751mm(w) x 162mm(h) x 404mm(d)

Approximate weight (shelf):
10 lbs / 5 kg

Shipping

Ships in box

Shipping dimensions:
Special order - 30" (l) x 16" (h) x 4" (d)
762mm(l) x 407mm(h) x 102mm(d)

Approximate total shipping weight:
12 lbs / 6 kg

additional information:

-Shelf can hold suggested max weight 15 lbs

-If shipping with backwall kit cases may vary

We are continually improving and modifying our product range and reserve the right to vary the specifications without prior notice. All dimensions and weights quoted are approximate and we accept no responsibility for variance. E&OE. See Graphic Templates for graphic bleed specifications.

Included In Your Freestanding Display Shelf

Components, Connectors & Extrusions

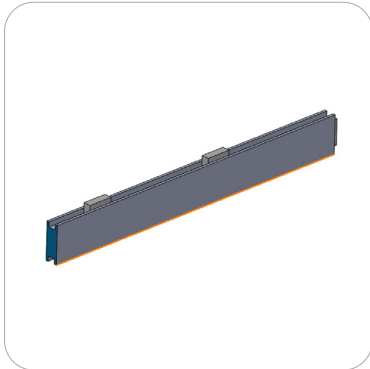

PH-400-L-SIDE-MK x2



PE-1200 x2
*will ship preattached to shelf



CT21-MK-SHELF x1



LN605-EN x2

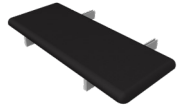

Exploded View

PM4S3-MK-SHELF

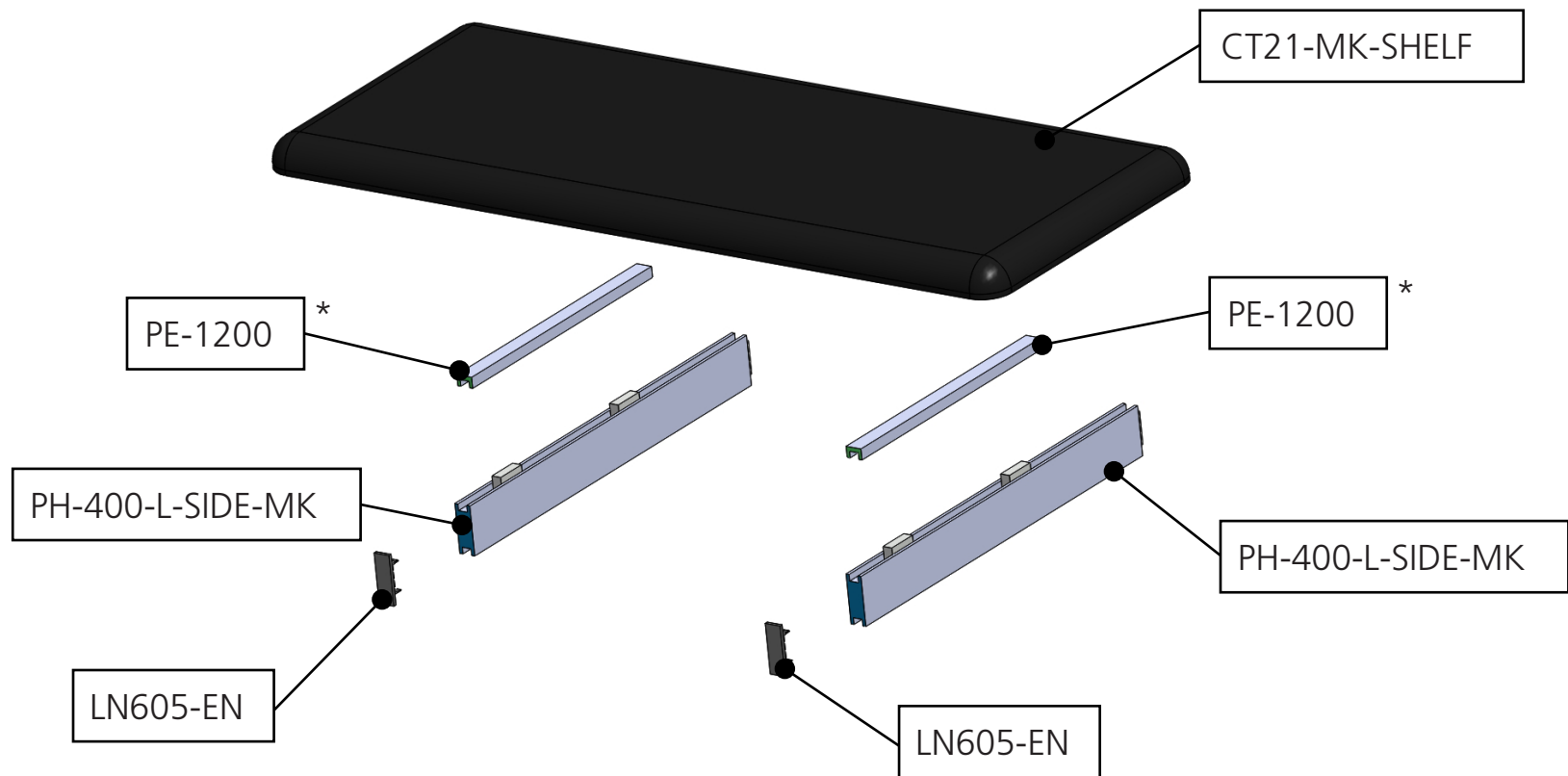

*Note: PE will ship preattached to shelf

Kit Assembly

Step by Step - Shelf

Step 8.

Insert the LN605-EN end caps. Lock the CT21-MK-SHELF to the PH-400-L-SIDE-MK. Do not over tighten.

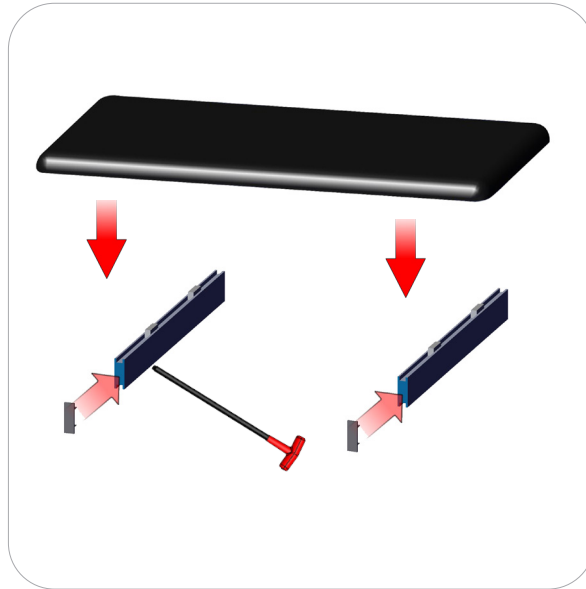

Step 7.

Lock your PH-400-L-SIDE-MK into the PM453 stacks at the desired dimension height. Do not over tighten.

Refer to the attached supplemental sheet for details on shelf height(s).

Setup is complete.

Repeat steps 7 and 8 twice more for Shelf Unit.



Location of vinly adhesive tape
Tape color-**CLEAR**

Indicator shown in green to show detail

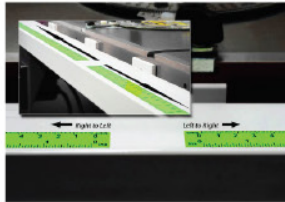

TORQUATA
Self-Adhesive Measuring
Tape

Note: tape comes preattached to extrusion,
0" starts from the bottom (at the floor)

