

Hybrid Pro 20ft Modular Backwall Kit 22

HP-K-22

Hybrid Pro™ Modular Kit 22 is a dynamic modular exhibit that features an 8' tall backwall, two sidewalls, six shelves for small product display and three monitor mounts that holds a medium sized monitor. Push-fit SEG fabric graphics that are easy to apply to the backwall and the interior and exterior facing side walls.



Hybrid pro counters are optional
not included at base price

features and benefits:

- Silver aluminum extrusion frames (3)
- SEG push-fit fabric graphics (5)
- Shelf color options: Silver, Black, Mahogany, Natural
- Medium monitor bracket holds 32-55" LCD*, max weight: 80 lbs

- Ships freight in a roto-molded protective shipping case
- Lifetime hardware warranty against manufacturer defects

dimensions:

Hardware

Assembled unit:
234.69" w x 95.45" h x 37.94" d
5961.13mm(w) x 2424.43mm(h) x
983.68mm(d)

Approximate weight:
348 lbs / 157.85kg

Graphic

Refer to related graphic template for more information.

Visit:
www.exhibitors-handbook.com/graphic-templates

Shipping

Packing case(s):
NCRATE

Shipping dimensions:
NCRATE
60" l x 57" h x 48" d
1524Mm(l) x 1448mm(h) x 1220mm(d)

Approximate total shipping weight: 573 lbs /
260 kg

additional information:

Graphic material:
Dye-sublimation SEG push-fit fabric

When included in a larger kit, a different packaging solution will be listed to accommodate all contents of the kit. Individual packaging no longer provided.

Tabletop Colors:

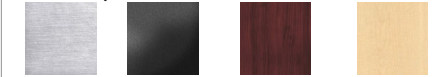

silver black mahogany natural

3person assembly recommended:



We are continually improving and modifying our product range and reserve the right to vary the specifications without prior notice. All dimensions and weights quoted are approximate and we accept no responsibility for variance. E&OE. See Graphic Templates for graphic bleed specifications.

FABRIC, VINYL & UV GRAPHIC CARE GUIDELINES



GENERAL HANDLING FABRIC GRAPHICS

- Your fabric graphics should always be handled in a clean, dry area with clean hands. When possible, use white fabric gloves.
- Be sure fabric is clean and dry before packing.
- Machine washing and/or drying is not recommended for all fabrics. Refer to chart below for which fabrics are washable.

EMERGENCY STAIN TREATMENT (FABRIC)

- For dry stains, like loose dirt or pencil marks, try initially using masking tape or Magic Eraser (dry-not moistened).
 - Masking tape or MagicEraser (dry) can be quite effective at lifting dry, surface dirt. Try 'pulling' as much of stain away as you can. Avoid rubbing stain into fabric.
- Introduce water or liquid cleaner for stains not responsive to masking tape or dry Magic Eraser.
 - When using liquids to treat stains, if at all possible, treat the stain with fabric off of the frame.
 - Place a clean dry cloth behind stain (to absorb stain while being treated). Moisten another cloth initially with just water (distilled water is optimal, if available).
 - Gently blot stain with moistened cloth (or small area of moistened Magic Eraser), while trying to push stain through to the back, using the dry cloth to absorb.
 - Repeat using care to keep the wet area as small as possible.
- Grandma's Secret Spot Remover can be an effective stain remover. Mix several drops in a small cup with clean water. Repeat above technique, taking care to keep wet area as small as possible and using dry cloth on back of stain to absorb.

MACHINE WASHING FABRIC GRAPHICS

- Cold water/delicate cycle/tumble dry low or air dry. For stretch fabrics do not use dryer, let hang dry.
- Use caution on dryer time with graphics containing liners. Its best to put tension fabric on frame when fabric is still damp and let it air dry. Always be sure that the aluminum frame is clean when mounting the damp graphic.
- Fabric stretch graphics that are washed and machine dried may shrink up to 3/4" per every 50" of fabric in the direction of the stretch and shrink up to 1/4" in the non stretch direction.

STORING & PACKING BACKLIT GRAPHICS

- To avoid cracks in the ink or having to steam graphics, Backlit fabrics should be loosely folded with bubble wrap or stored around a tube.
- Avoid folding the graphic tightly to store in a small bag or box.

GENERAL HANDLING VINYL & UV GRAPHICS

- Vinyl banners and rigid graphics should always be handled in a clean, dry area with clean hands. When possible, use white fabric gloves.
- Be sure vinyl/ UV is clean and dry before packing. Always follow material handling and packing instructions included.
- All vinyl materials should be rolled with graphics facing in to protect the graphic printed side. Roll on a tube if available.
- Avoid folding materials to reduce the risk of crease lines and chipped inks. If a graphic must be folded, try to fold loosely and as few times as possible.

EMERGENCY STAIN TREATMENT (UV)

- For drier stains, like loose dirt, pencil marks or adhesive, try initially using masking tape. Masking tape can be quite effective at lifting dry, surface dirt. Try 'pulling' as much of stain away as you can and avoid rubbing the stain into the material.
- When using Solvent to clean a stain be sure to avoid any image. Solvent is aggressive and will take the image off. Soapy water should be used at a ratio of 1 part Dawn® /10 parts water.
- While using Windex® avoid scrubbing harshly. Too much pressure can fade the graphic print.

GENERAL HANDLING OF ROLLABLE PVC PANELS

All mural panels, truss panels and detachables should be rolled with graphics facing out to protect the graphic printed side. Mural panels should be stored in the original plastic sleeves that are provided with the panels.

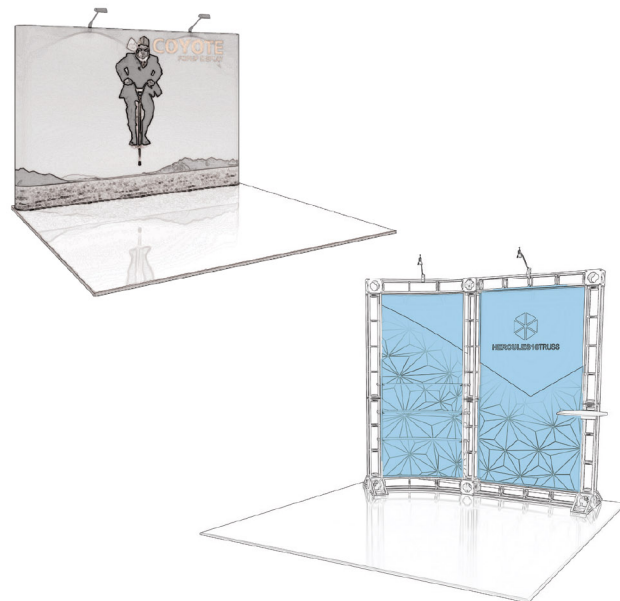

FABRIC, VINYL & UV GRAPHIC CARE GUIDELINES



STEAMING FABRIC GRAPHICS

- For optimal results, steam wrinkles when fabric is tensioned and installed securely on the frame.
- Fill steamer with clean drinking water or distilled water. Avoid using water containing hard minerals.
- Hold steamer upright and hold close to fabric. Avoid touching fabric with steamer.
- Do not tip steamer as water drips may cause water marks to form on graphic.

NON BACKLIT FABRIC

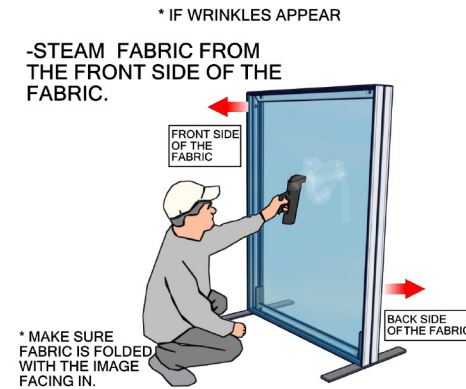

BACKLIT FABRIC

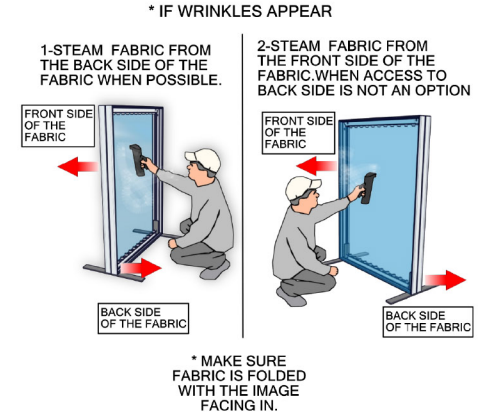

HANDLING REFERENCE CHART

FABRIC	WASHING MACHINE	DRY CLEAN	SPOT CLEAN	STEAMING/ IRON	MAGIC ERASER
RESILIENCE	NO	NO	NO	NO	YES (ONLY ON WHITE)
OXFORD	YES	YES	YES	YES	YES
POWER STRETCH	YES	YES	YES	YES	YES
DISPLAY POLYESTER	YES	YES	YES	YES	YES
DISPLAY POLY CONVERTIBLES TABLE THROWS	YES (MUST VELCRO THE TABS)	YES (MUST VELCRO THE TABS)	YES	YES	YES
OUTDOOR FLAG	YES	N/A	YES	YES	YES
CANVAS OUTDOOR	NO	NO	YES	STEAM ONLY	YES
CANVAS LIGHTBOX	NO	NO	NO	STEAM ONLY	YES
AGILITY	YES	YES	YES	(ONLY W/ 100% TENSION)	YES
SUPER STRETCH	YES	YES	YES	(ONLY W/ 100% TENSION)	YES
TRIPLE WHITE	YES	YES	NO	YES	NO
SOFT KNIT	YES	YES	YES	YES	YES
SHEER	YES	YES	YES	YES	YES

VINYL & ROLLABLE	SOLVENT	SOAPY WATER (DAWN®)	WINDEX®
FLATMAXX	ONLY ON WHITE	YES	NO
SCRIM 130Z/180Z	ONLY ON WHITE	YES	NO
VINYL 200Z	ONLY ON WHITE	YES	NO
MELINEX	NO	YES	NO
MURAL PANELS	NO	YES	YES
UV RIDGED	NO	YES	YES



Setup notes

1. Redesign of this exhibit without approval by manufacture may result in dangerous and unsafe structures. Manufacture disclaims any responsibility for redesigned exhibits it does not approve in writing.

2. Parts and components such as panels and extrusions are manufactured to metric sizing. Where ever possible sizes have been noted in feet and inches as well as in metric. Below is the imperial to metric sizing table as a reference. 'Nominal' refers to approximate sizes.

IMPERIAL TO METRIC SIZES

8' Nominal = 94 1/2" or 2400mm Actual
4' Nominal = 47 1/4" or 1200mm Actual
3' Nominal = 35 7/16" or 900mm Actual
2' Nominal = 23 5/8" or 600mm Actual
1' Nominal = 11 13/16" or 300mm Actual

TOP DOWN LAYOUT



Included In Your Kit

Tools, Components, & Connectors



HEX KEY SET x1

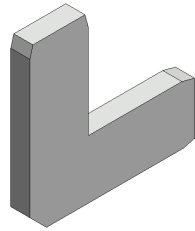

CB9 x4

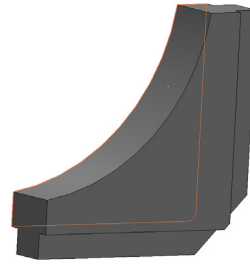

CBE-50 x32

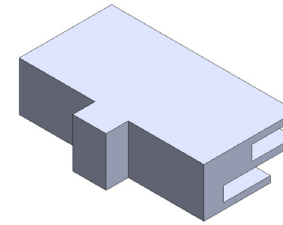

FC-50-SPCR x20

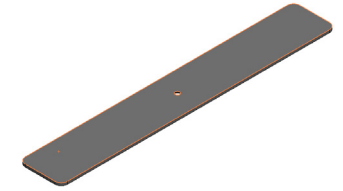

LN114-S2-650 x5

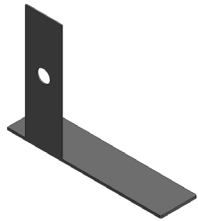

SW-FOOT-650-LN x2



PH4-300-TG x5

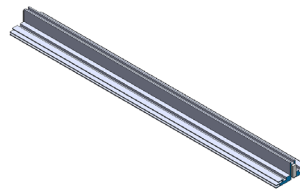

PHFC4-600-L-MCB9-x2

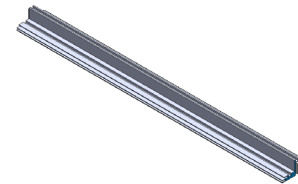

PHFC4-900-L-L x12



PHFC4-1200-L-MCB9x4

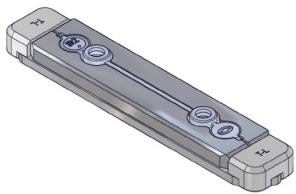

IB2-x2

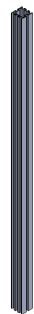

PM2S2-1200-A165-Nx10



PM4DSC-600x2



PMFC4-90-1193-A315x4

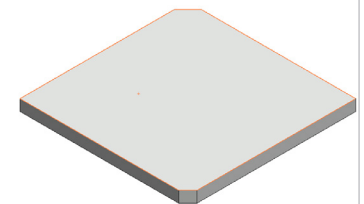

PMFC4-90-CAP x4

Code	#	Description
A4	10	PM2S2-1200 EXTRUSION-WITH NUT INSERT-WITH STOP AT 165MM
A1	12	PHFC4-900 EXTRUSION-WITH CAM LOCKS-WITH CAM LOCKS
A5	5	300MM PH4 EXTRUSION WITH TENSION GLIDES
A2	4	1193MM LENGTH OF PMF4-90 EXTRUSION-WITH STOP AT 315MM
A3	2	PM4DSC-600 - 600MM 4-WAY INTERNAL CONNECTION EXTRUSION W/ 8 TENSION GLIDE

ASSEMBLE MAIN FRAME

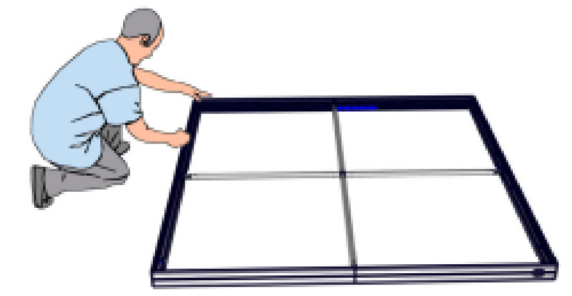
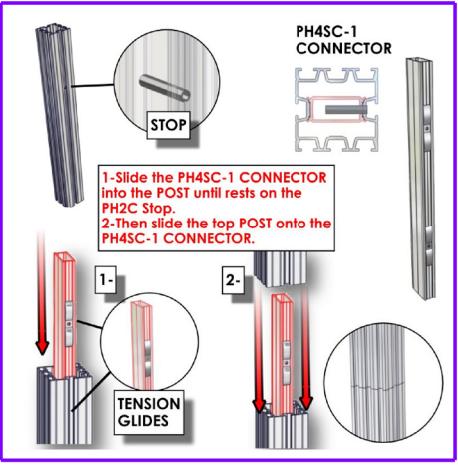
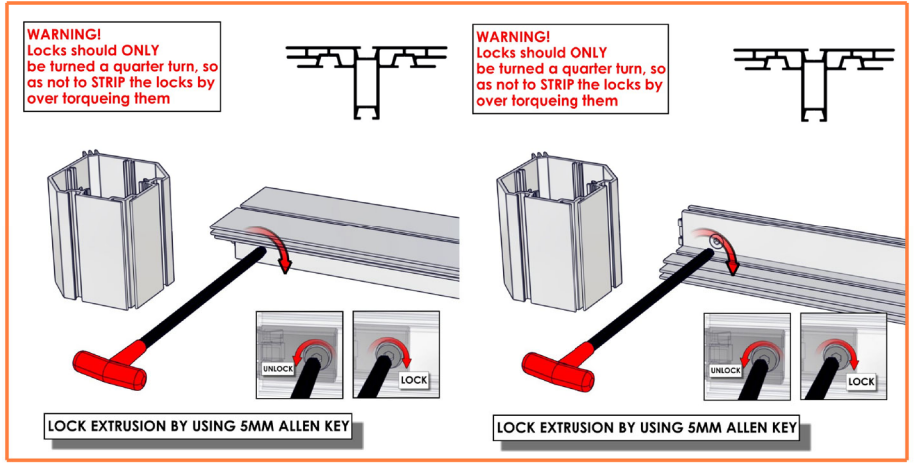

- BUILD FRAMES ON FLAT GROUND
- GATHER ALL PARTS NEEDED
- LAY THEM OUT IN PLACE BEFORE BUILDING

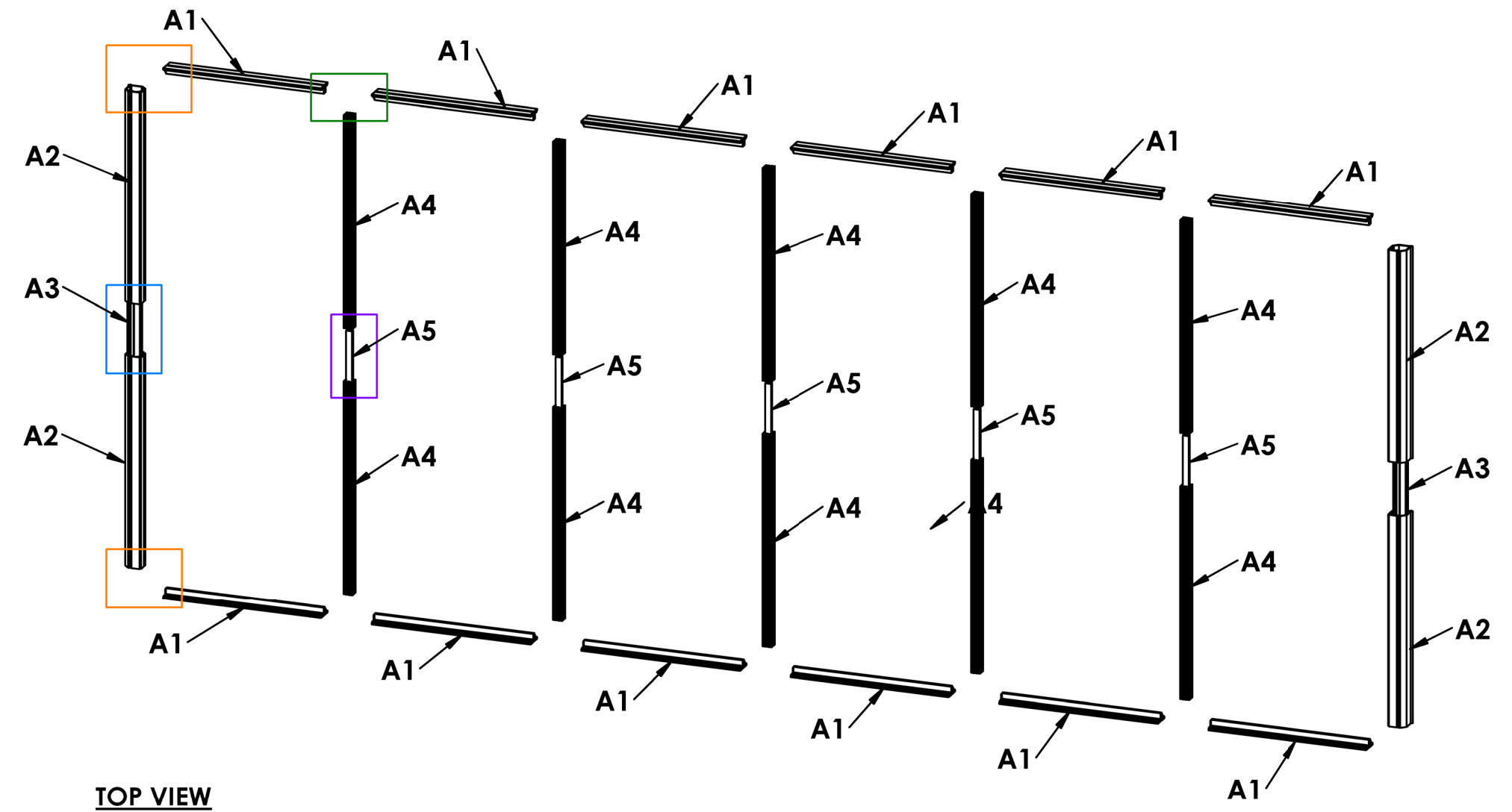
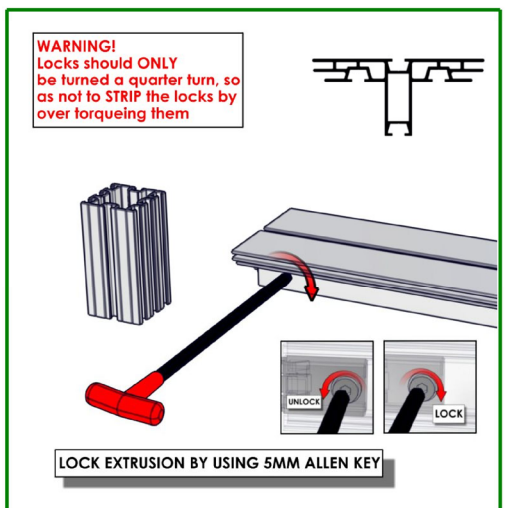
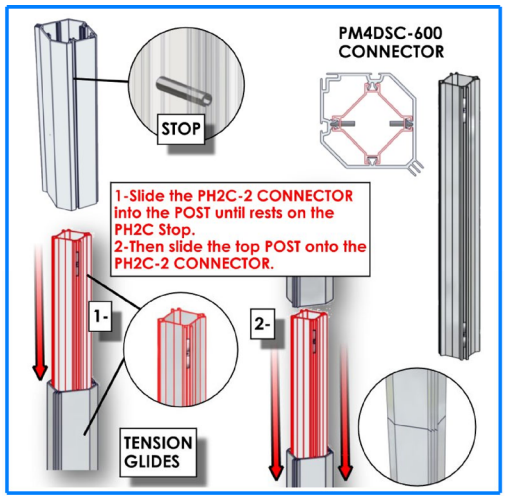

TOP VIEW



Code	#	Description
LN114-S2-650	5	FOOT PLATE , 650MM LENGTH

ATTACH BASE PLATES

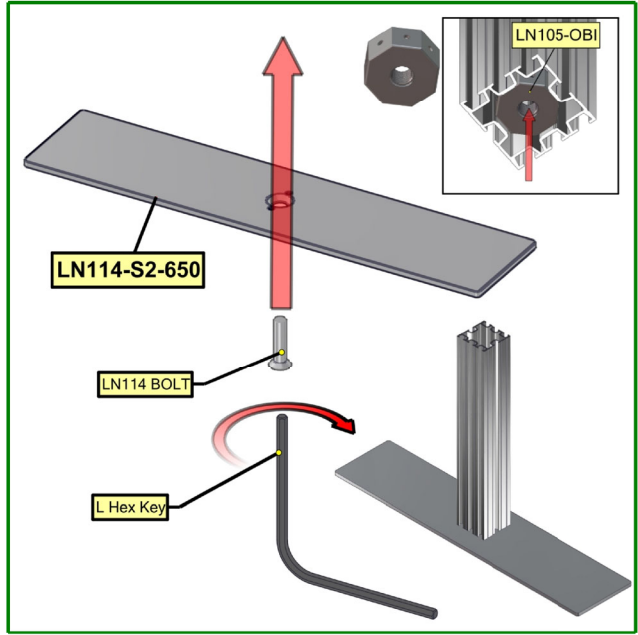

**HAVE TWO OR MORE PEOPLE HELP
STAND THIS UP AFTER FEET ARE INSTALLED**

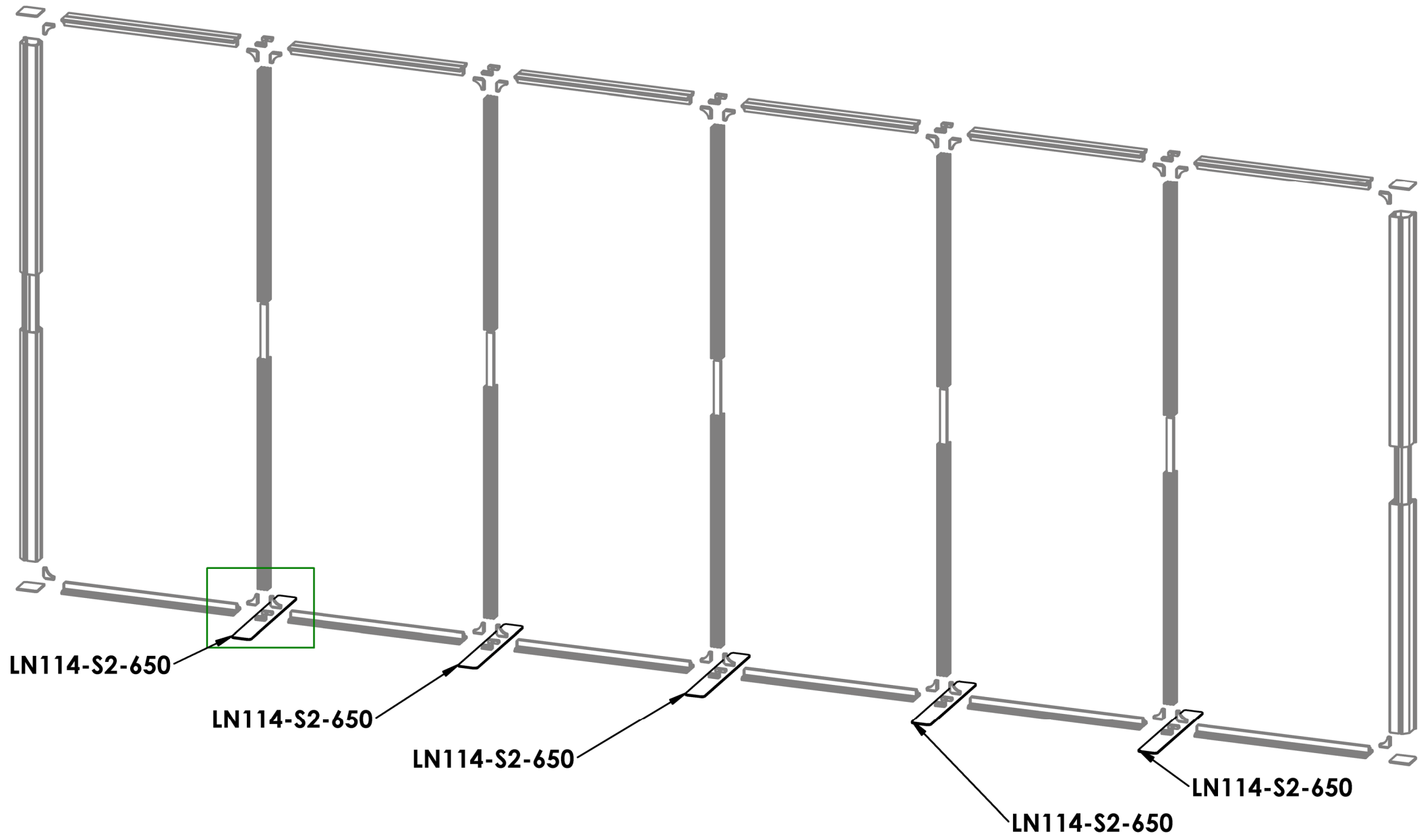
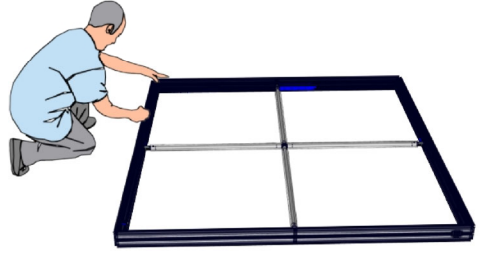

TOP VIEW

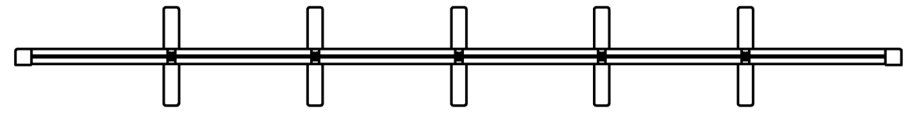

Code	#	Description
A7	2	PHFC4-600 EXTRUSION-WITH CAM LOCKS-WITH MITRE CUT FOR CB9
CB9	2	90 degree joiner
A6	2	PHFC4-1200 EXTRUSION-WITH IB2 LOCK HOLE-WITH MITRE CUT FOR CB9
CUS-SW-FOOT-650-LN	1	SMART WALL FOOT , CUT DOWN TO 425MM
IB2	1	JOINER BAR(NEW DESIGN)
CBE-50	4	CORNER PRESSURE FIT CONNECTOR

ASSEMBLE RIGHT SIDE WALL

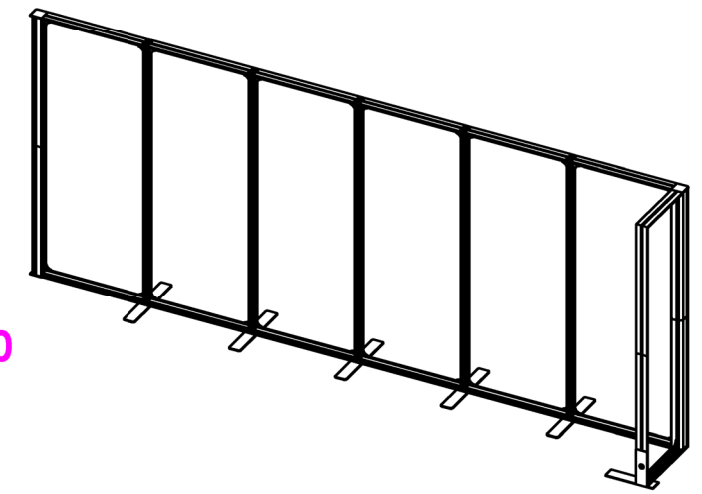
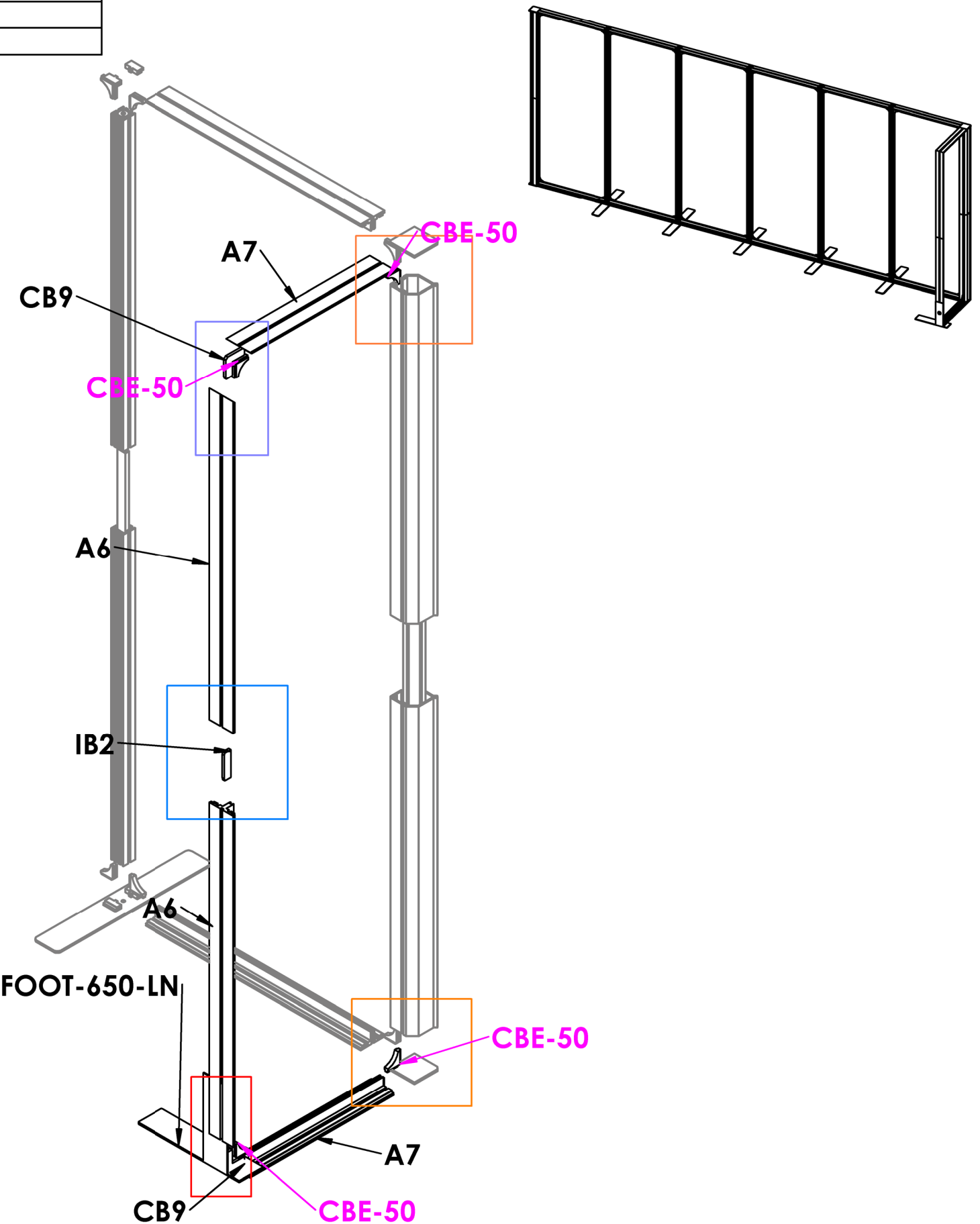
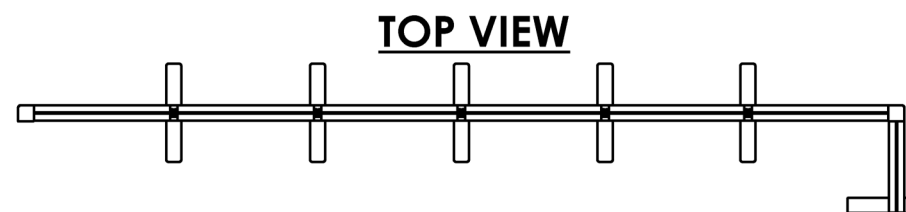
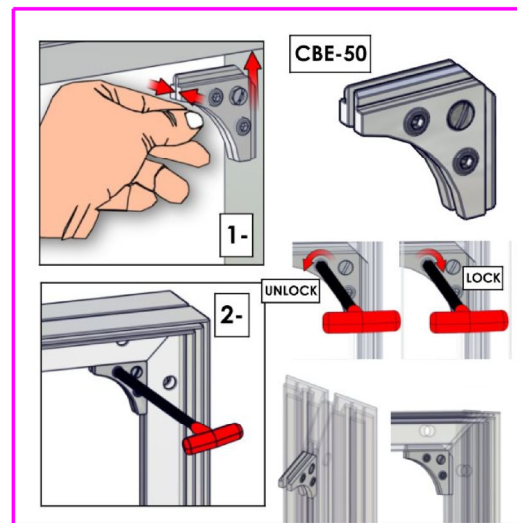
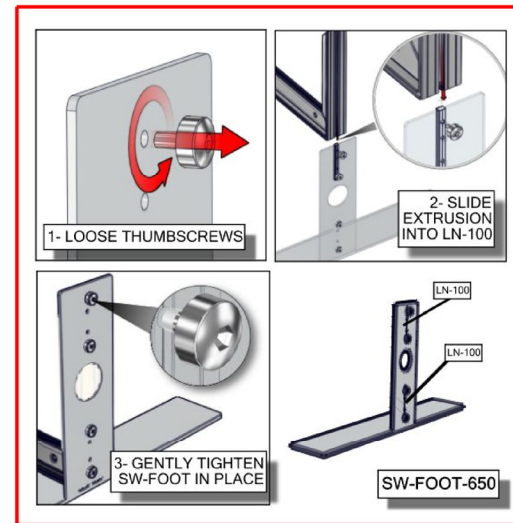
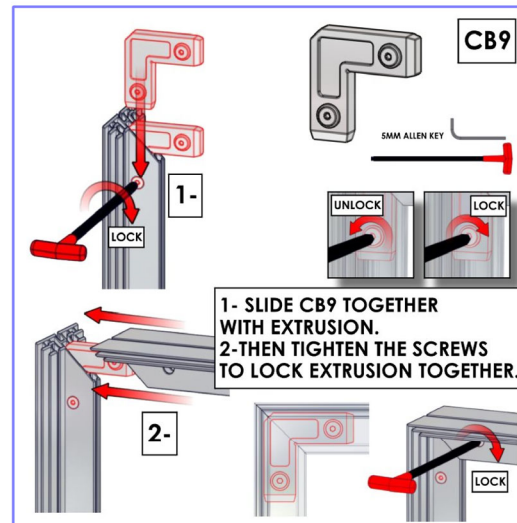
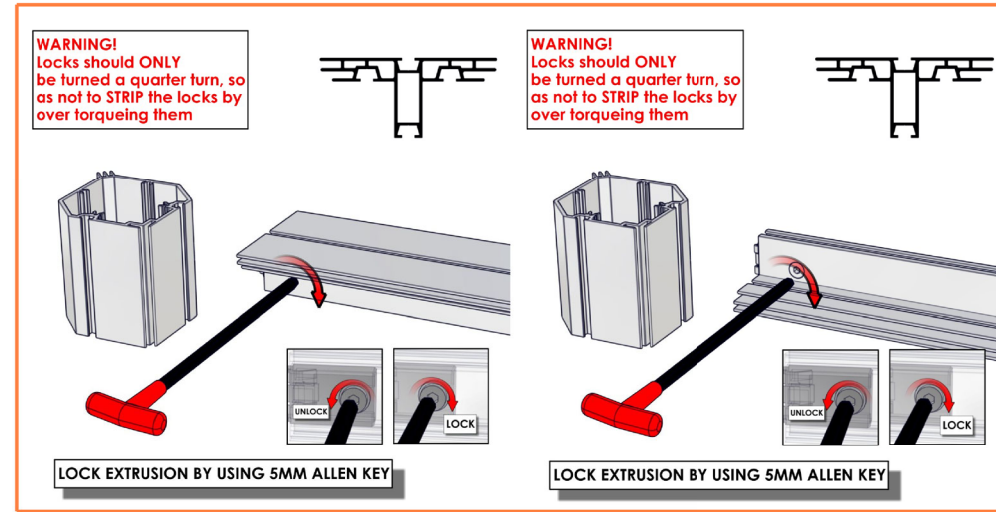
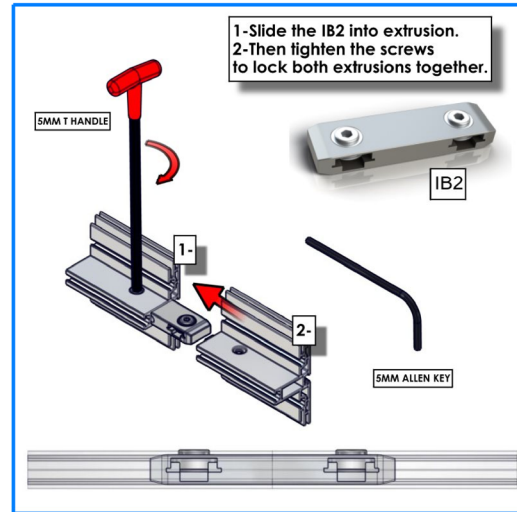

Code	#	Description
A6	2	PHFC4-1200 EXTRUSION-WITH IB2 LOCK HOLE-WITH MITRE CUT FOR CB9
A7	2	PHFC4-600 EXTRUSION-WITH CAM LOCKS-WITH MITRE CUT FOR CB9
IB2	1	JOINER BAR(NEW DESIGN)
CB9	2	90 degree joiner
CBE-50	4	CORNER PRESSURE FIT CONNECTOR
CUS-SW-FOOT-650-LN	1	SMART WALL FOOT , CUT DOWN TO 425MM

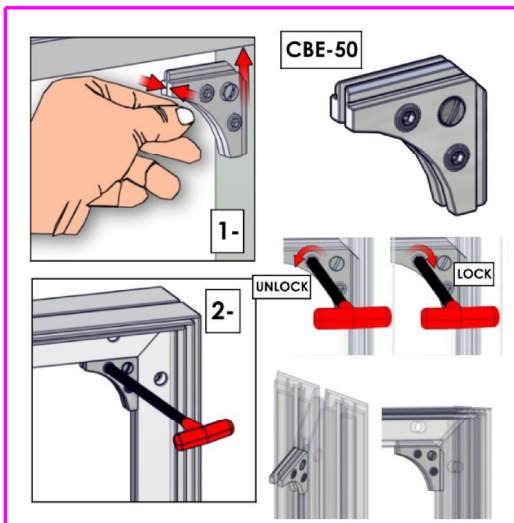
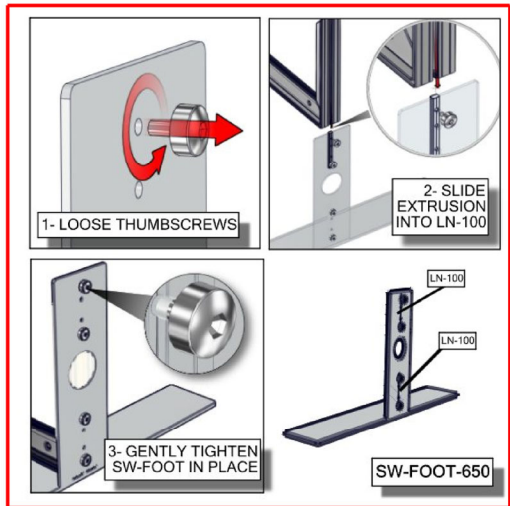
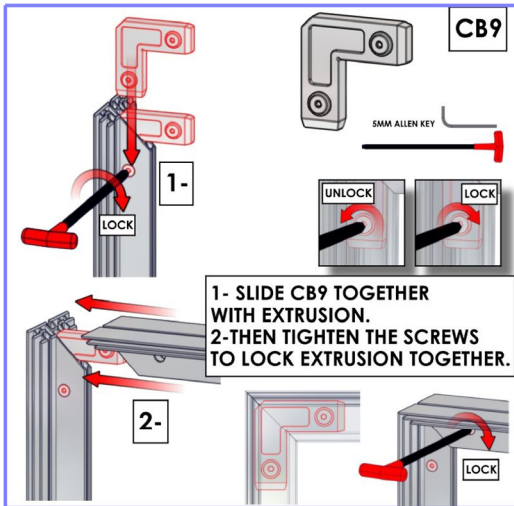
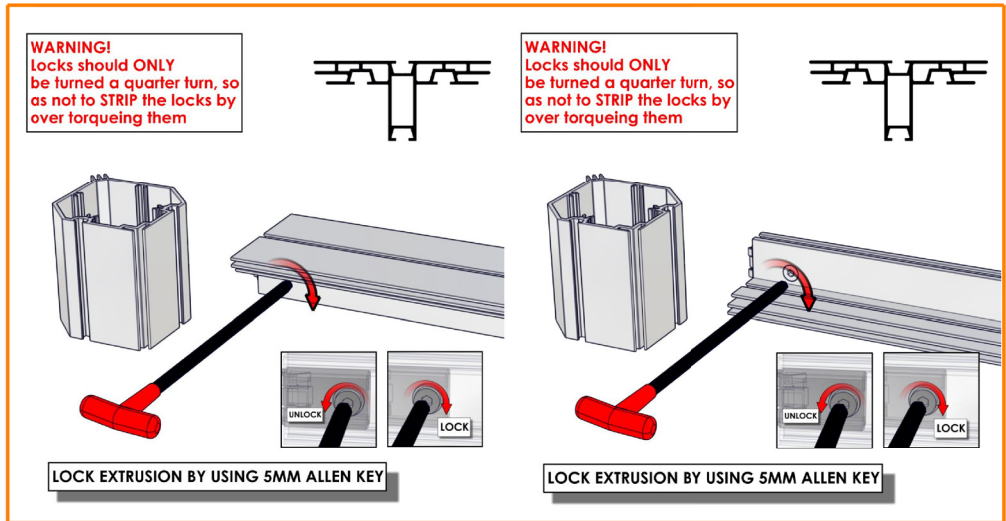
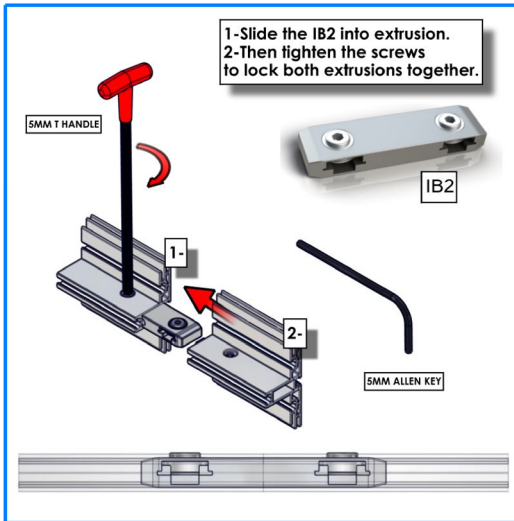

ASSEMBLE LEFT SIDE WALL

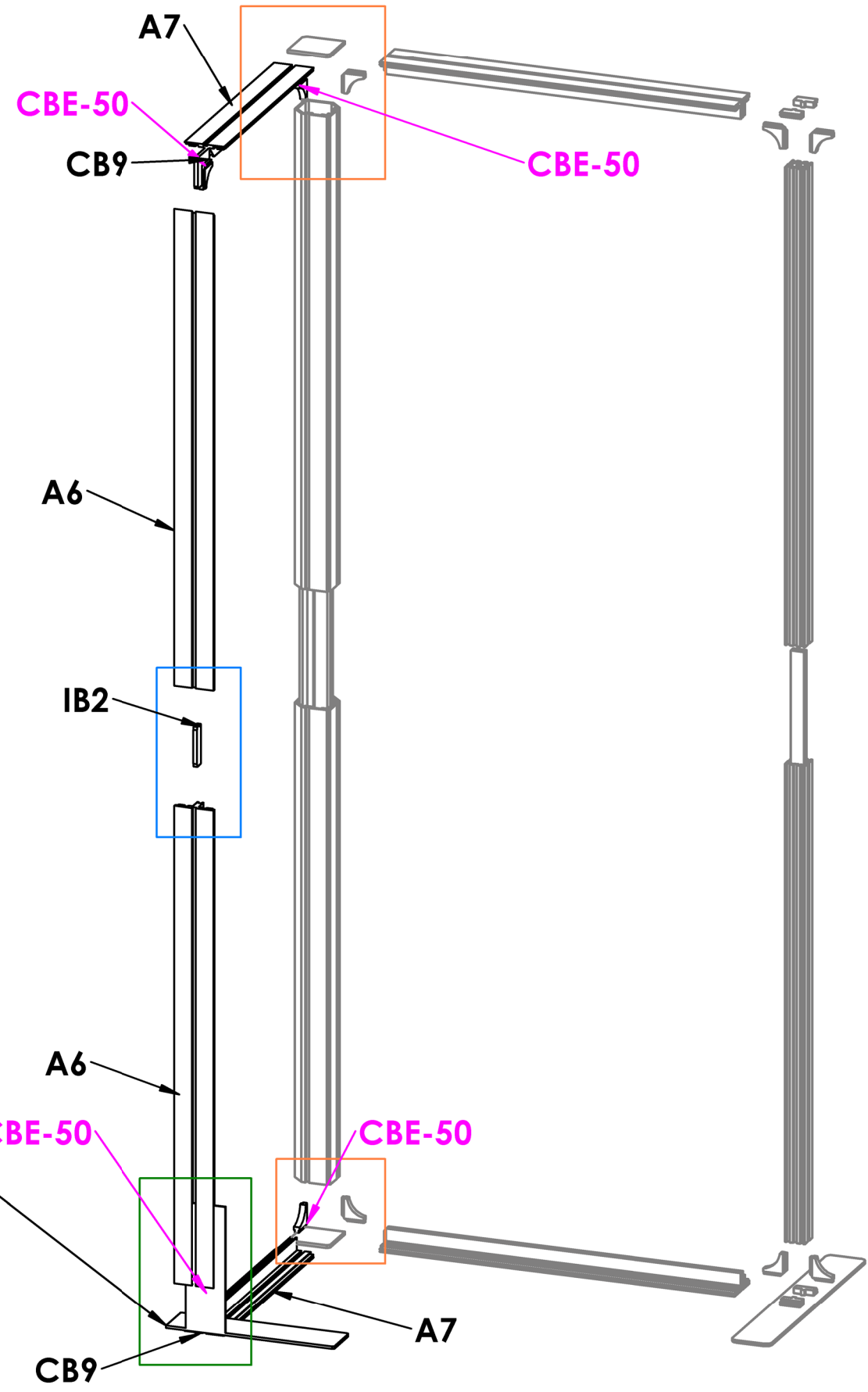

TOP VIEW

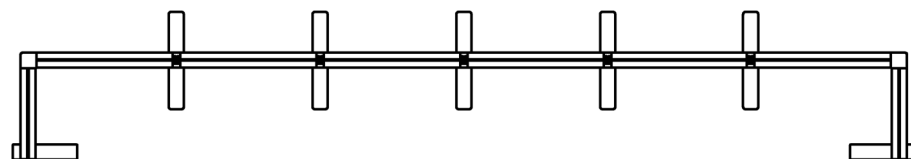

Code	#	Description
HP-K-22-LN-D2	1	LINER(D2) 230.67 w X 94.37 h finished size Opaque liner, with FCE-2 silicone beading sewn to back perimeter, corner pull sewn in bottom right corner
HP-K-22-G-A1	1	GRAPHIC(A1) 27.68 w X 94.37 h finished size Dye-sub print on 8oz. Power Stretch, with FCE-2 silicone beading sewn to back perimeter, corner pull sewn in bottom right corner
HP-K-22-G-B1	1	GRAPHIC(B1) 23.62 w X 94.37 h finished size Dye-sub print on 8oz. Power Stretch, with FCE-2 silicone beading sewn to back perimeter, corner pull sewn in bottom right corner
HP-K-22-G-C1	1	GRAPHIC(C1) 222.56 w X 94.37 h finished size Dye-sub print on 8oz. Power Stretch, with FCE-2 silicone beading sewn to back perimeter, corner pull sewn in bottom right corner
HP-K-22-G-D1	1	GRAPHIC(D1) 23.62 w X 94.37 h finished size Dye-sub print on 8oz. Power Stretch, with FCE-2 silicone beading sewn to back perimeter, corner pull sewn in bottom right corner
HP-K-22-G-E1	1	GRAPHIC(E1) 27.68 w X 94.37 h finished size Dye-sub print on 8oz. Power Stretch, with FCE-2 silicone beading sewn to back perimeter, corner pull sewn in bottom right corner

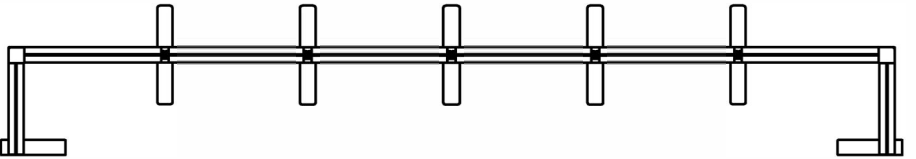
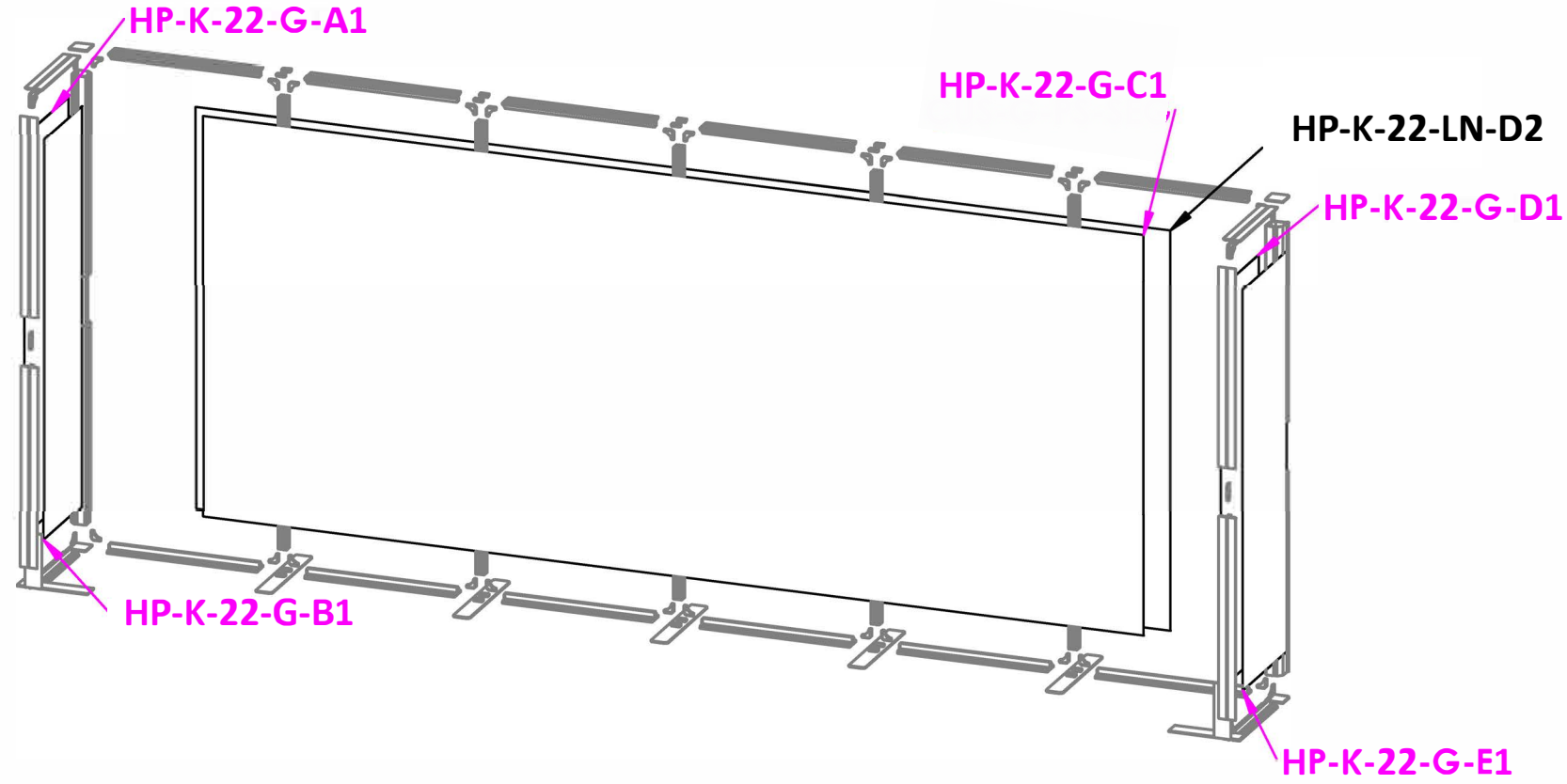
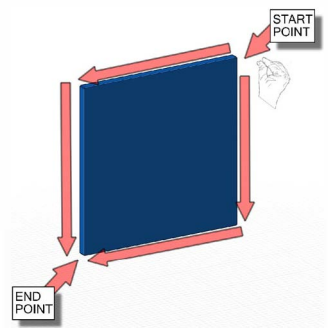
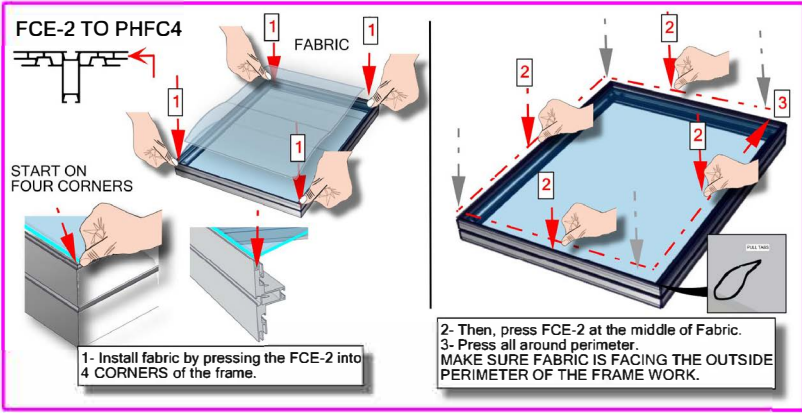
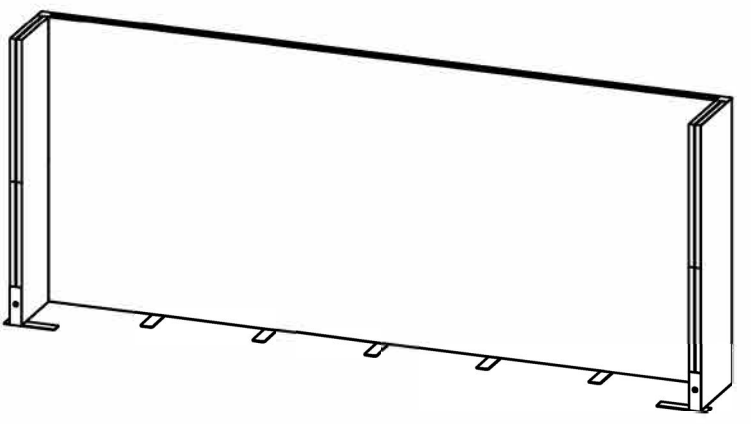

Freestanding Monitor Kiosk

PM4S3-MK-M
PM4S3-MK-L

PM4S3-MK-M-MSHELF
PM4S3-MK-L-MSHELF

PM4S3-MK-SHELF-UNIT

The Freestanding Monitor Kiosk is a superior multimedia display that can be used for multiple applications, as well as in trade show exhibits and for events. Kiosks include monitor mounts to support a medium or large size TV, and a corresponding medium or large shelf may be added. Monitor mounts support TV's up to 40 lbs and 32" - 65" in size, and can be adjusted to the perfect height; an included shelf can hold up to 15 lbs. The Shelf Unit is a great addition that proudly displays small products. Install the Freestanding line behind a fabric backwall for a truly impressive display.



Freestanding Monitor Kiosk

Freestanding Monitor Kiosk with Shelf

Freestanding Shelf Unit

features and benefits:

- Premium aluminum extrusion frames with cam lock and tension glide assembly
- Easy to store and ship
- Quick to set up
- Weighted feet for added stability
- Kits may include: a medium or large monitor mount, shelf, or combination
- Choice of medium or large shelf for display opportunities (Freestanding Monitor Kiosk with Shelf or Freestanding Shelf)
- Lifetime limited hardware warranty against manufacturer defects

dimensions:

Hardware

Assembled unit (no shelf):
25.59" w x 70.98" h x 25.59" d
650mm(w) x 1803mm(h) x 650mm(d)

Assembled unit (with shelf):
29.53" w x 70.98" h x 25.59" d
751mm(w) x 1803mm(h) x 650mm(d)

Approximate weight:
(excludes cases & monitor mount)

40 lbs / 19 kgs

Add 10 lbs / 5 kgs for each shelf

Shipping

Packing case(s):
1 OCE Case

Shipping dimensions:
OCE: Expandable case length (l) may vary
40" - 66" l x 18" h x 18" d
1016mm-1677mm(l) x 458mm(h) x 458mm(d)

Approximate total shipping weight:
Monitor Kiosk:
(Case & monitor mount)
Medium
83 lbs / 38 kgs
Large
85 lbs / 39 kgs

additional information:

-Medium monitor mount can hold 32-55" monitor/ max weight 40lbs

-Large monitor mount can hold 40"-65" monitor/ max weight 40lbs

-Monitor not included

-Shelf can hold suggested max weight: 15 lbs

-If shipping with backwall kit cases may vary

Monitor Kiosk with Shelf:
(Case, monitor mount, & shelf)

Medium
93 lbs / 43 kgs
Large
95 lbs / 44 kgs

Shelf Unit:
(Case & shelves)
116 lbs / 53 kgs

We are continually improving and modifying our product range and reserve the right to vary the specifications without prior notice. All dimensions and weights quoted are approximate and we accept no responsibility for variance. E&OE. See Graphic Templates for graphic bleed specifications.

Included In Your Freestanding Shelf

Tools, Components, Connectors & Extrusions



5MM ALLEN-T x1

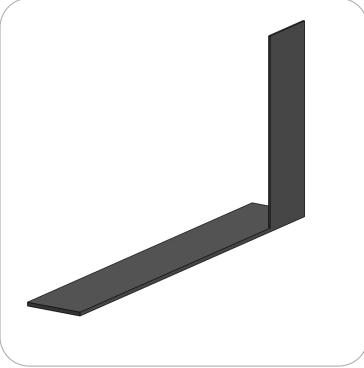

PM4S3-MM-FOOT-L x1



PM4S3-MM-FOOT-R x1



LN100 x6

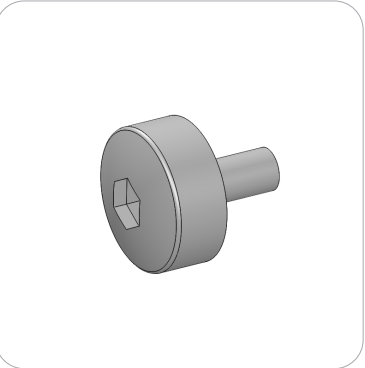

M5 THUMBSCREW x8



PH2-350-L-L x3

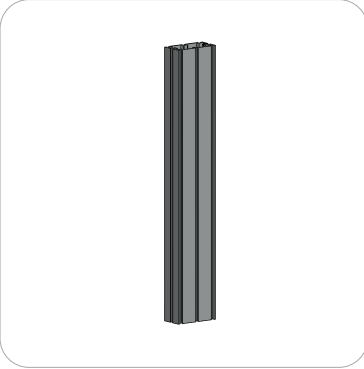

PM4S3-600-A165-A165 x2



PM4S3-1200-A165-A165 x2



PH2-300-TG x2

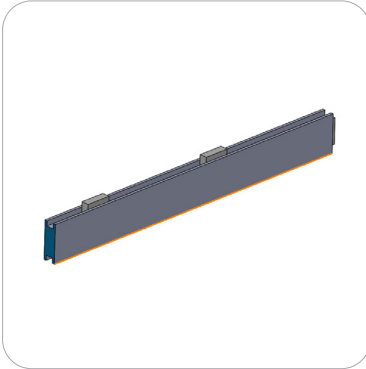

PH-400-L-SIDE-MK x6

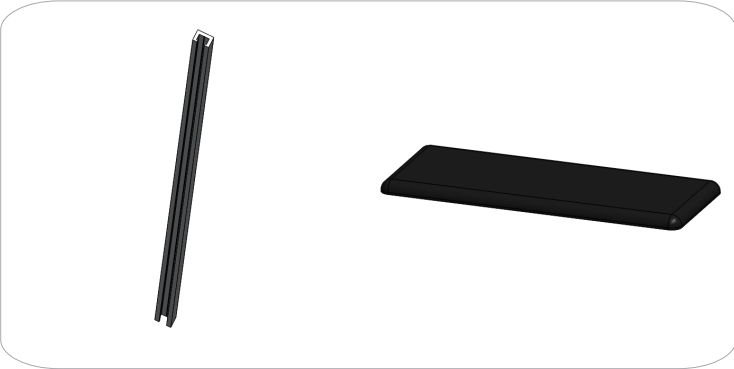

PE-1200 x6
*will ship preattached to shelf



CT21-MK-SHELF x3



LN605-EN x6



Exploded View

PM4S3-MK-SHELF-UNIT

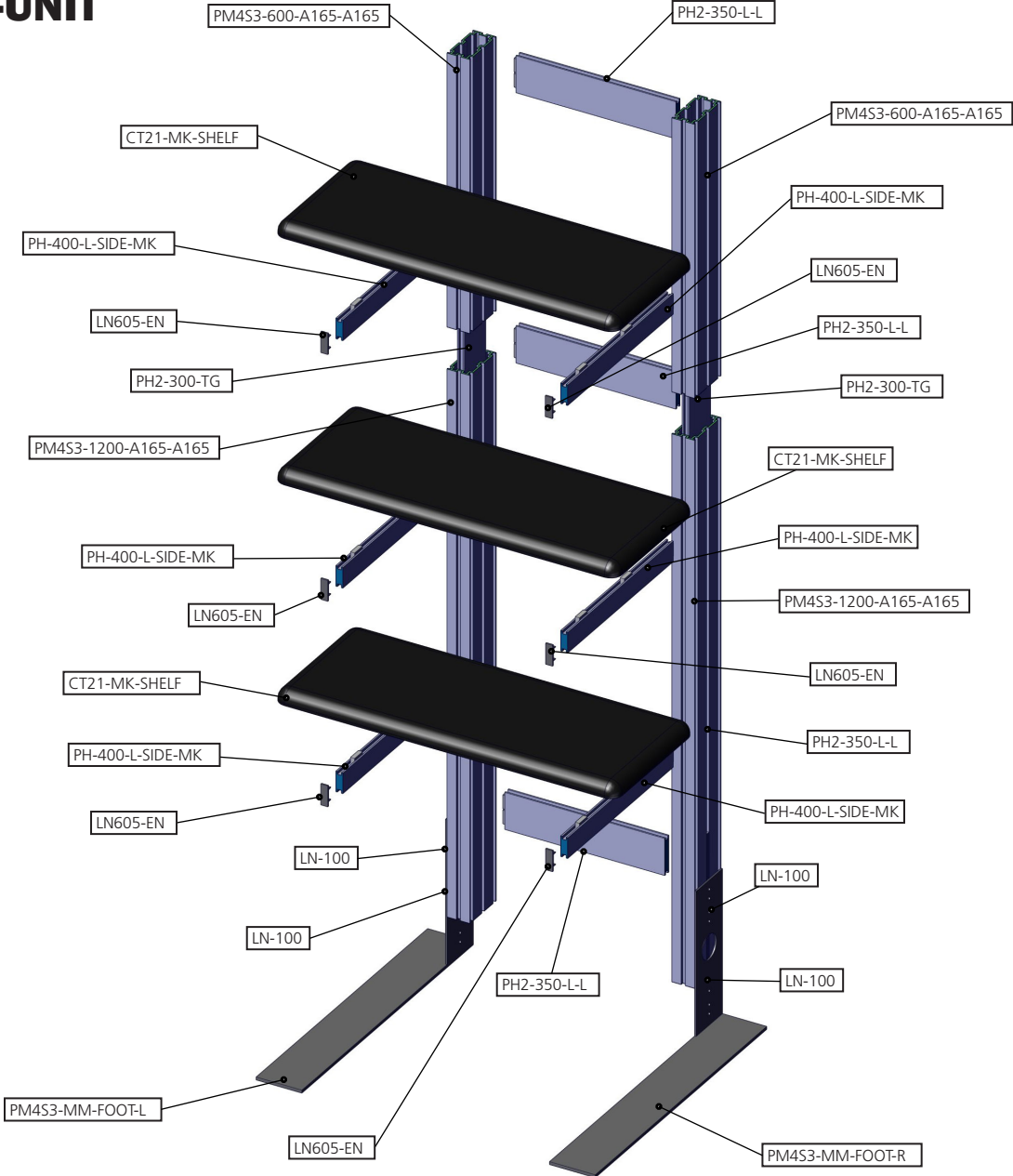

Kit Assembly

Step by Step

Step 1.

Reference the image to the right. Locate the coded extrusions. Slide the PH2-300-TG connector into one end of the PM4S3-1200-A165-A165 so that it goes as deep as the internal pins. Connect the PM4S3-600-A165-A165 by sliding it over the PH2-300-TG. Repeat for this step for the second vertical.

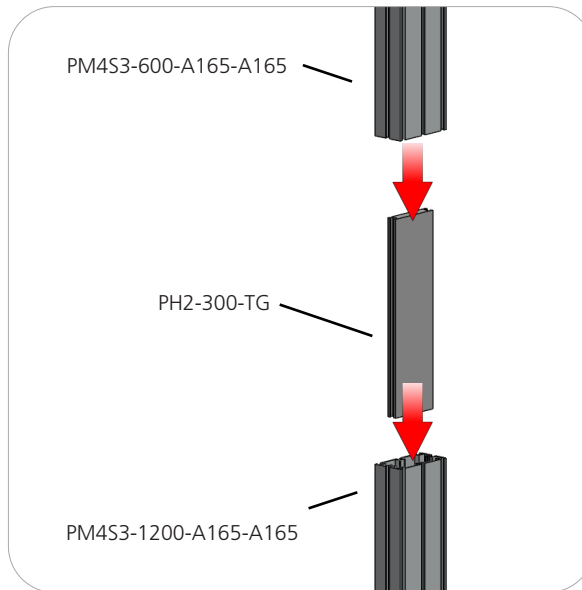

Step 2.

Collect your extrusions and handtool. Using the provided handtool, lock the extrusions into the back channel of the three channel PM4S3 faces as shown in the image below. Be sure the locks face toward the back of the assembly and do not over tighten.

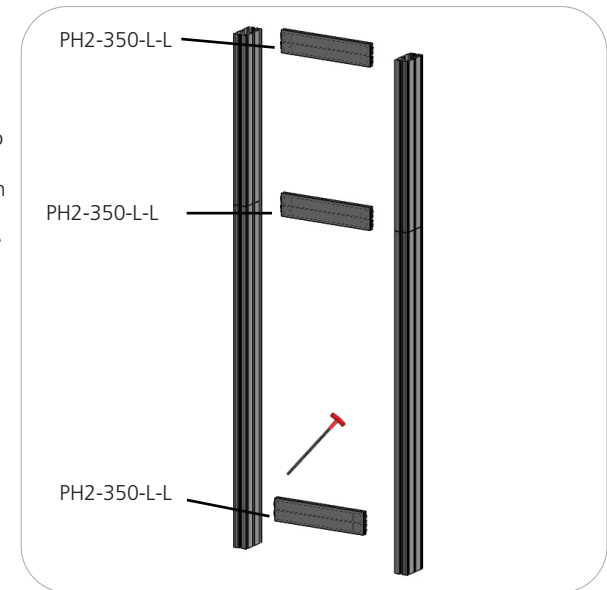
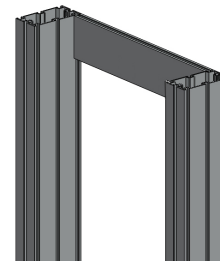

Step 3.

Locate the M5 thumbscrews, LN100s, and the PM4S3-MM stabilizing bases. Slide the LN100s into the middle channel of the PM4S3. Hand screw the M5 thumbscrews through the base holes and into the LN100 holes. Use the handtool to securely fasten the M5 Thumbscrews. Do not over tighten.

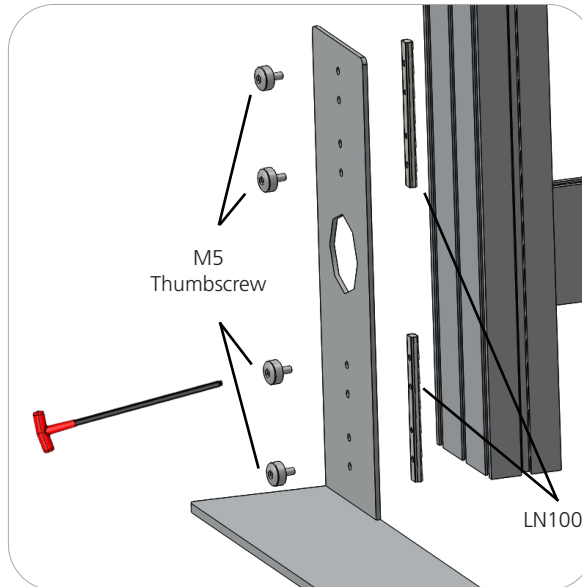

STOP

Orbus recommends that you move your kiosk(s) in place before continuing on with the rest of assembly.

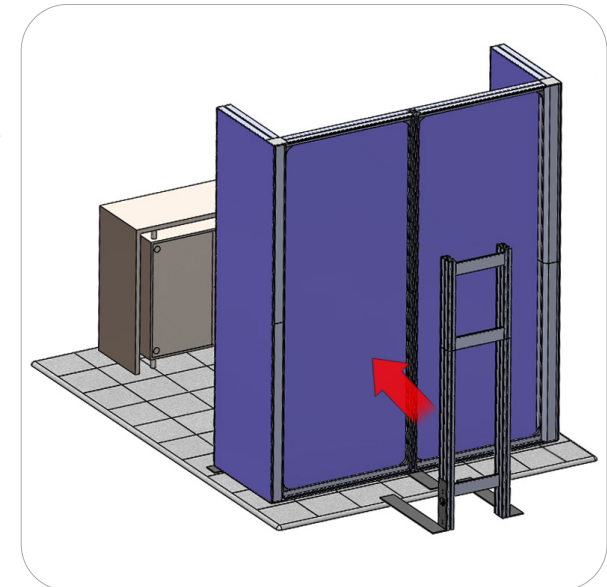

Kit Assembly

Step by Step - Monitor Mount

Step 4.

This step is for kiosks with monitor mounts. Skip to step 7 for shelf kiosks.

Measure from the ground to the center of the hole in your main kit's graphic. Lock the center of your PH5-100-L-L into the PM4S3 stacks at the dimension height of the graphic hole. Do not over tighten.

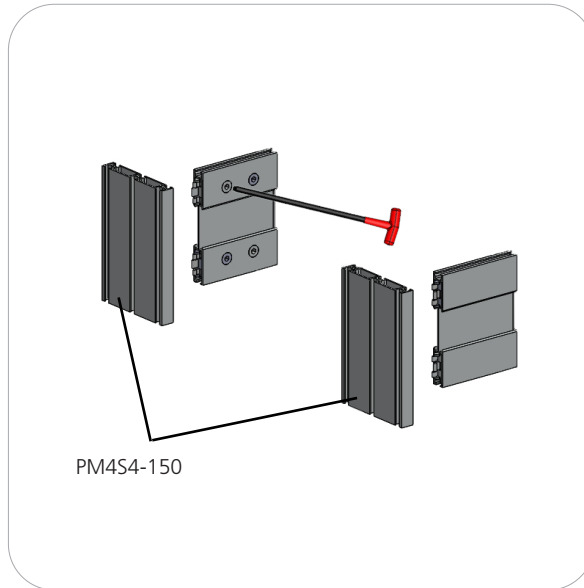
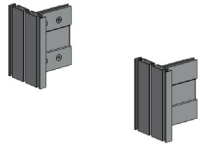

Step 5.

NOTE: Your main backwall assembly must be completed with graphics before completing this step of the monitor kit.

Lock your PM4S4-150 to the ends of the PH5-100-L-L. Do not over tighten.

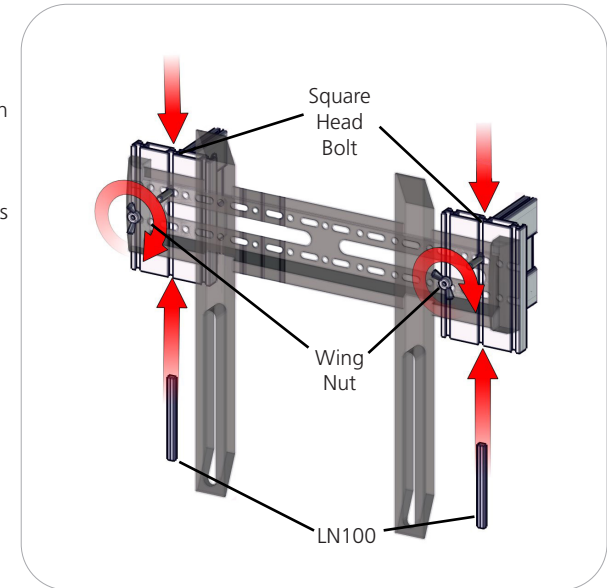

Step 6.

Set your monitor stand so that the extrusion arms fit through the graphic hole. Use the provided fastening hardware to complete your monitor stand. Slide the LN100 into the bottom center channel of the PM4S4-150. Next, slide the Square Head Bolt into the top center channel of the PM4S4-150. Apply the monitor bracket and spacer washer before fastening with the wingnut. Monitor mount may vary depending on size. Monitor not included.

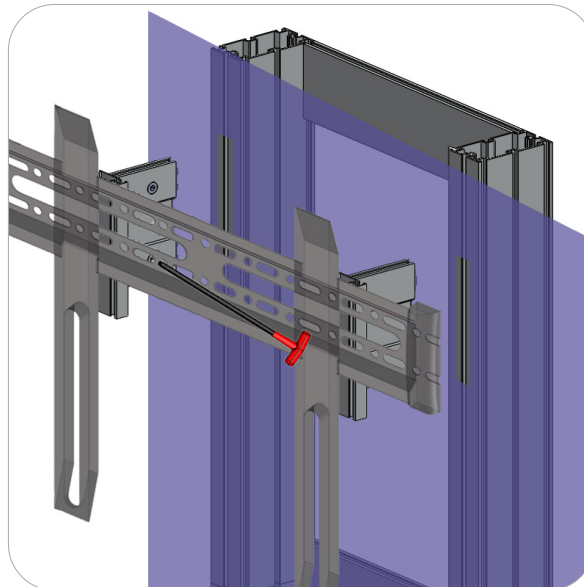

Kit Assembly

Step by Step - Shelf

Step 7.

Insert the LN605-EN end caps. Lock the CT21-MK-SHELF to the PH-400-L-SIDE-MK. Do not over tighten.

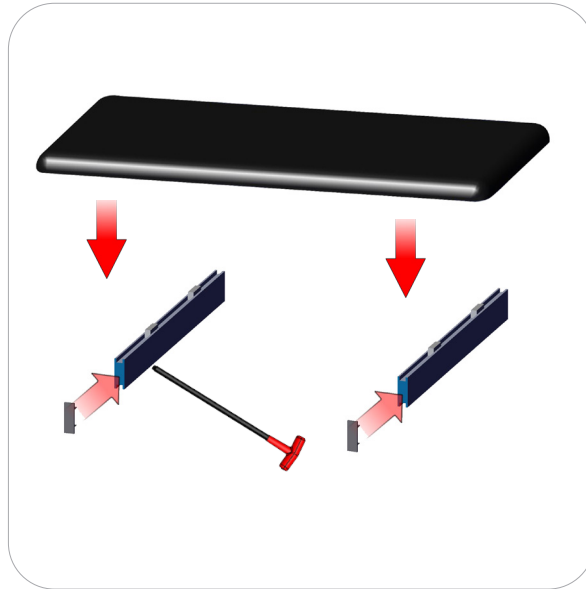

Step 8.

Lock your PH-400-L-SIDE-MK into the PM453 stacks at the desired dimension height. Do not over tighten.

Refer to the attached supplemental sheet for details on shelf height(s).

Setup is complete.

Repeat steps 7 and 8 twice more for Shelf Unit.



Freestanding Display Shelf

PM4S3-MK-SHELF

Freestanding display shelves are easily attached to your assembled kiosk for displaying promotional materials. This shelf can be added to a Freestanding Monitor Kiosk order.

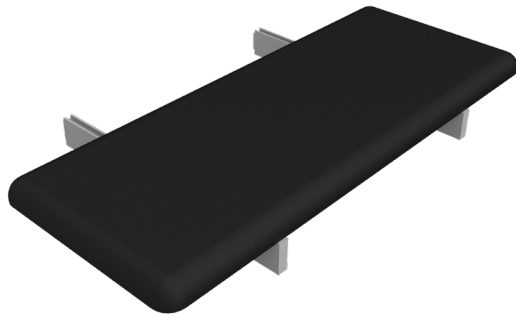

features and benefits:

- Premium aluminum extrusion frames with cam lock and tension glide assembly
- Easy to store and ship
- Quick to set up
- Lifetime limited hardware warranty against manufacturer defects
- Great for display opportunities

dimensions:

Hardware

Assembled unit:
Medium or Large

29.53" w x 6.35" h x 15.87" d
751mm(w) x 162mm(h) x 404mm(d)

Approximate weight (shelf):
10 lbs / 5 kgs

Shipping

Ships in box

Shipping dimensions:
Special order - 30" (l) x 16" (h) x 4" (d)
762mm(l) x 407mm(h) x 102mm(d)

Approximate total shipping weight:
12 lbs / 6 kgs

additional information:

-Shelf can hold suggested max weight 15lbs

-If shipping with backwall kit cases may vary

We are continually improving and modifying our product range and reserve the right to vary the specifications without prior notice. All dimensions and weights quoted are approximate and we accept no responsibility for variance. E&OE. See Graphic Templates for graphic bleed specifications.

Included In Your Freestanding Display Shelf

Components, Connectors & Extrusions

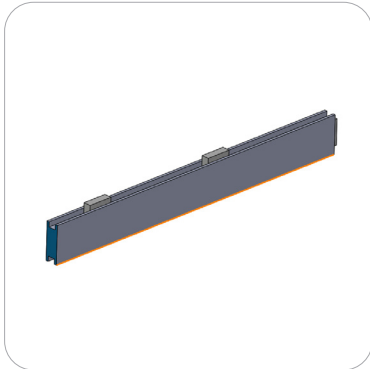

PH-400-L-SIDE-MK x2



PE-1200 x2
*will ship preattached to shelf



CT21-MK-SHELF x1



LN605-EN x2

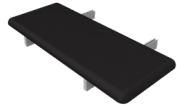

Exploded View

PM4S3-MK-SHELF

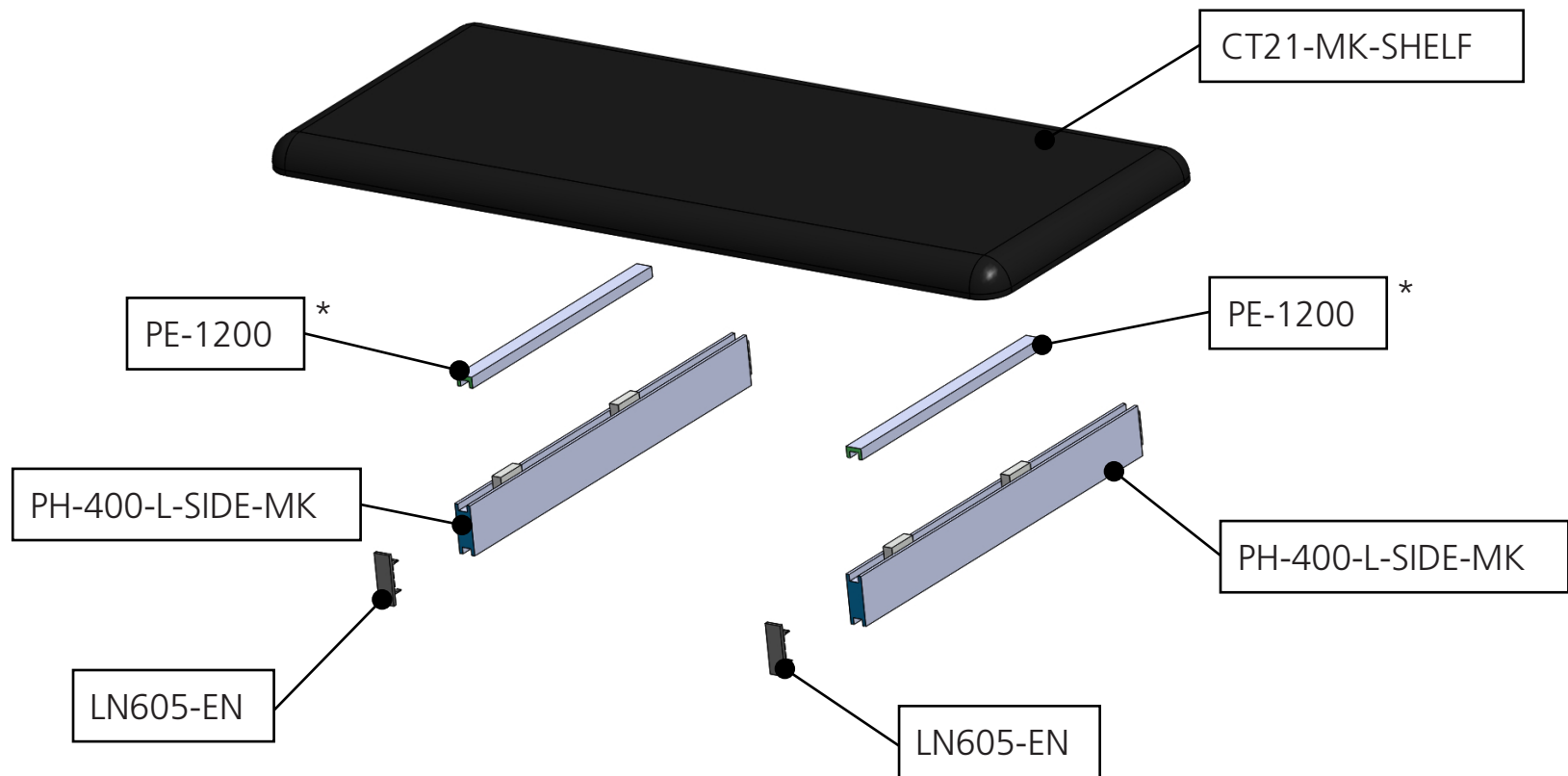

*Note: PE will ship preattached to shelf

Kit Assembly

Step by Step - Shelf

Step 8.

Insert the LN605-EN end caps. Lock the CT21-MK-SHELF to the PH-400-L-SIDE-MK. Do not over tighten.

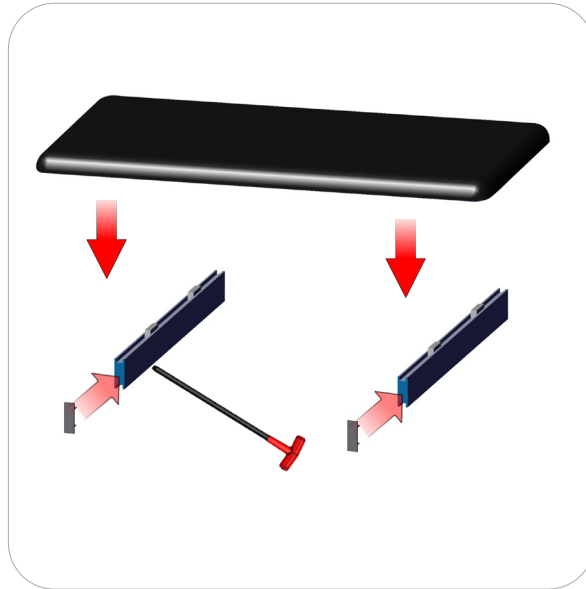

Step 7.

Lock your PH-400-L-SIDE-MK into the PM453 stacks at the desired dimension height. Do not over tighten.

Refer to the attached supplemental sheet for details on shelf height(s).

Setup is complete.

Repeat steps 7 and 8 twice more for Shelf Unit.



Location of vinyl adhesive tape
Tape color-**CLEAR**

Indicator shown in green to show detail

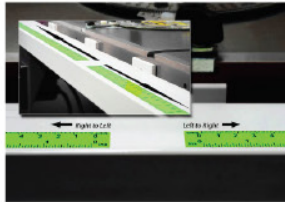

TORQUATA
Self-Adhesive Measuring
Tape

Note: tape comes preattached to extrusion,
0" starts from the bottom (at the floor)

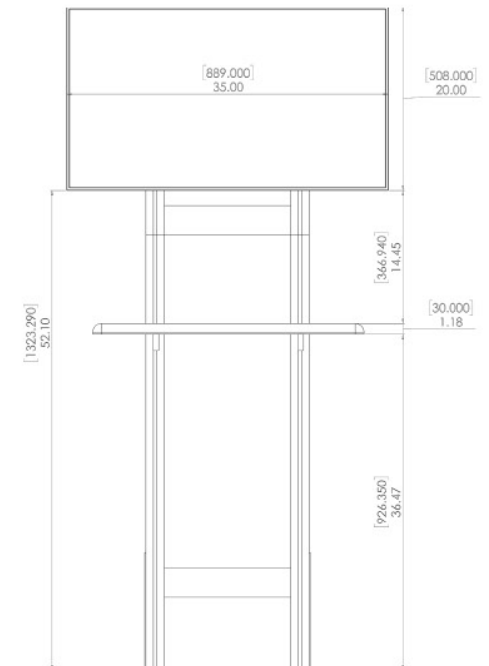
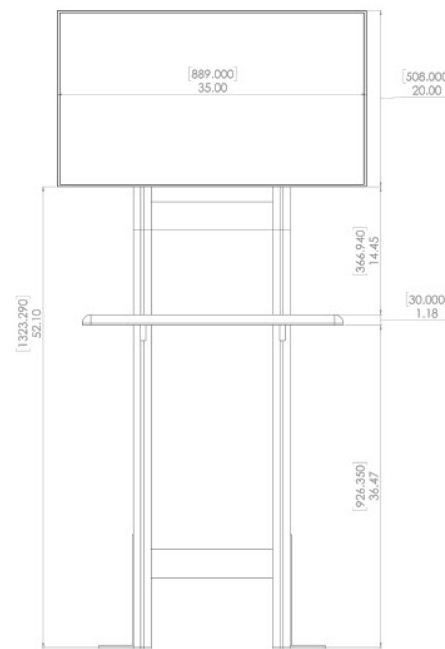
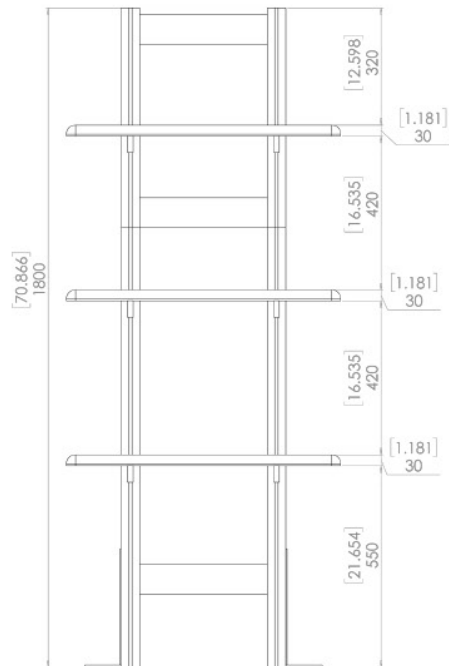

Code	#	Description
EXT-M-MB	3	EXTRUSION MOUNTED MEDIUM MONITOR BRACKET AND MOUNTING HARDWARE

MONITOR MOUNT

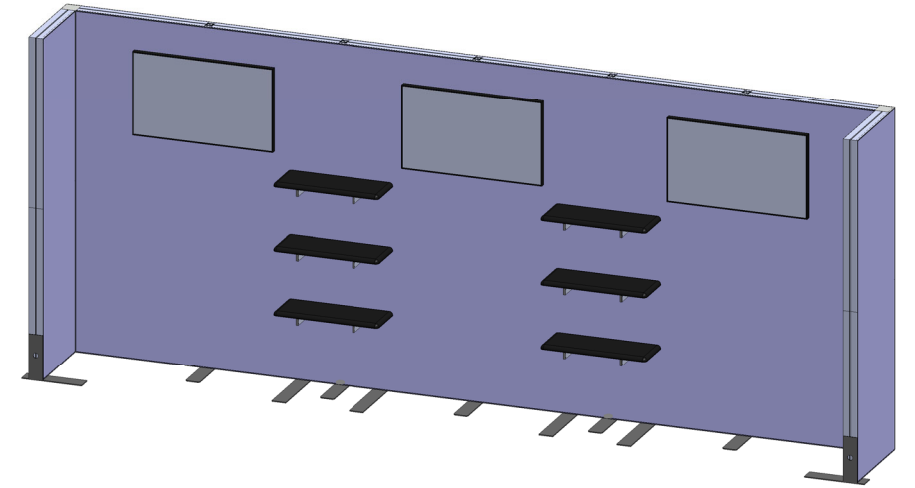
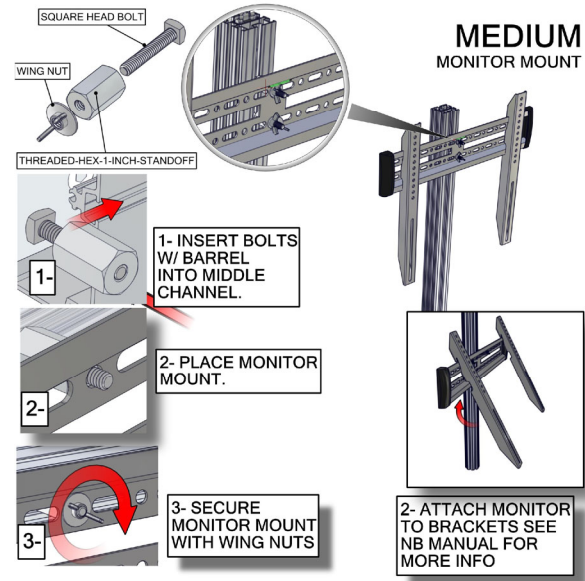

THE BOLTS THAT WERE INSERTED IN THE 3 COLUMNS WILL ATTACH TO THE MONITOR MOUNTS THOUGH GRAPHICS

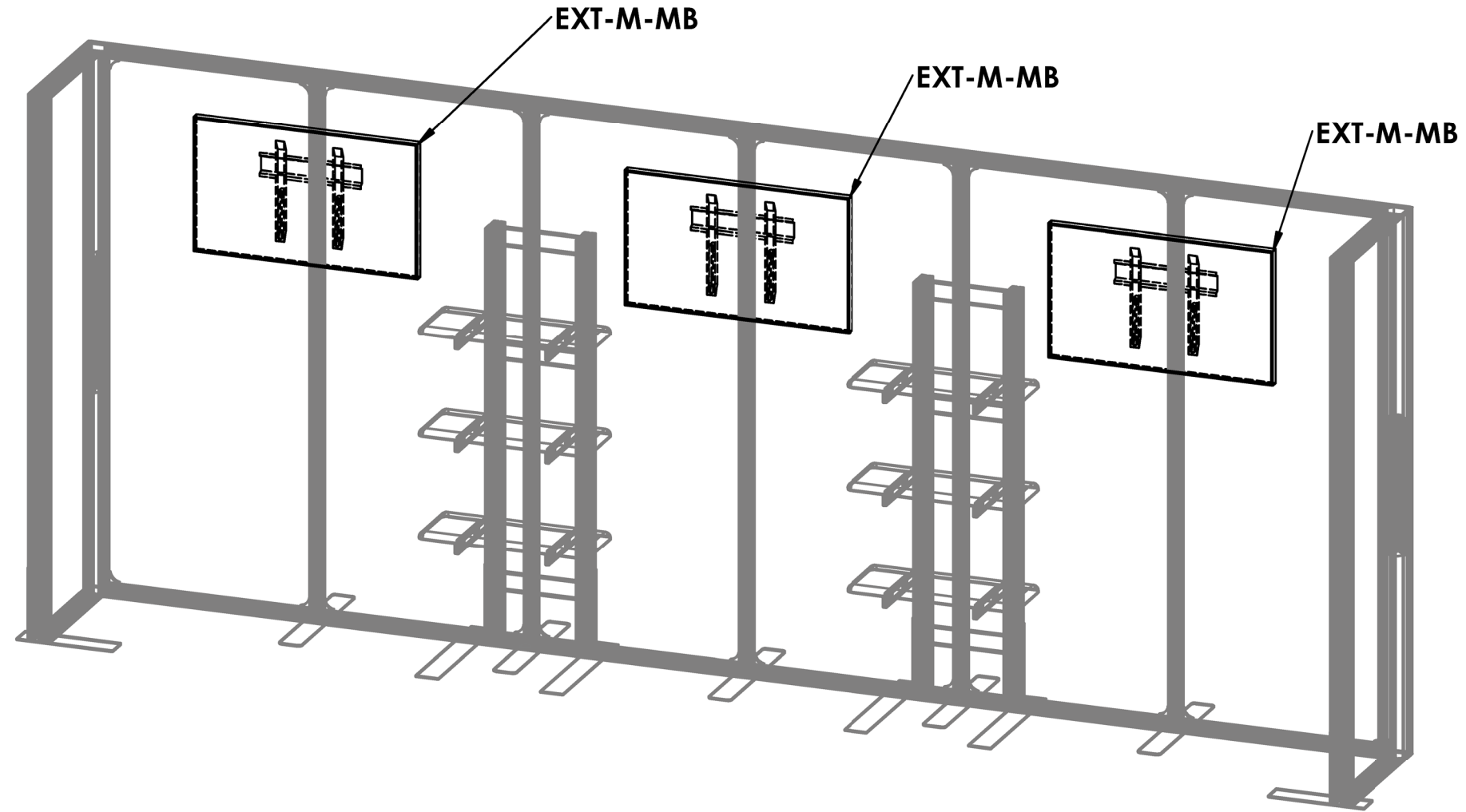

TOP VIEW

