

# Hybrid Pro Modular Kit 17

## HP-K-17

Hybrid Pro™ Modular exhibits and counters are a perfect solution for the serious exhibitor. Exhibits feature heavy-duty aluminum extrusion frames and push-fit fabric graphics. Count on making an unforgeable impact with Hybrid Pro Modular exhibit kits, counters, and accessories.



## features and benefits:

- Silver aluminum extrusion frame
- 15' 9" tall 20' x 20' island display
- Base structure features white laminate panels for the accessible storage closet with lockable door on the narrow side
- Lifetime hardware warranty against manufacturer defects

- Kit includes: accessible lockable storage space, four pillowcase graphics, two fabric graphic velcro panels, three wing shaped Sintra panels, three counters, six small monitor mounts, six spotlights, two molded shipping cases and one wooden shipping crate

## dimensions:

### Hardware

Assembled unit:  
222.25" w x 189" h x 217.36" d  
5645mm(w) x 4800mm(h) x 5521mm(d)

Approximate weight:  
973 lbs / 442 kgs

### Shipping

Packing case(s):  
1 WOODCRATE-H

Shipping dimensions:  
101" l x 53" h x 49" d  
2565mm(l) x 1346mm(h) x 1245mm(d)

Approximate total shipping weight:  
1353 lbs / 614 kgs

### Graphic

Refer to related graphic template for more information.

Visit:  
[www.exhibitors-handbook.com/graphic-templates](http://www.exhibitors-handbook.com/graphic-templates)

## additional information:

Graphic material:  
Dye-sublimation printed fabric  
UV printed White PVC

Small monitor bracket holds 17-37" LCD,  
max weight 40 lbs / 19 kgs each  
Monitors not included

Counters Dimensions:  
48" w x 94.5" h x 38" d  
Holds a max weight 50 lbs / 23 kgs

Center Tower Dimensions:  
102.36" w x 189" h x 43.3" d  
Storage Closet Area: 96" w x 36" d



Caution  
sharp edges  
on metal parts

### Panel Colors:



grey



black



white

### Tabletop Colors:



silver



black



mahogany



natural

**3 person assembly recommended:**



We are continually improving and modifying our product range and reserve the right to vary the specifications without prior notice. All dimensions and weights quoted are approximate and we accept no responsibility for variance. E&OE. See Graphic Templates for graphic bleed specifications.

# Included In Your Kit

Tools, Components, & Connectors



HEX KEY SET x1



5MM ALLEN-T x1

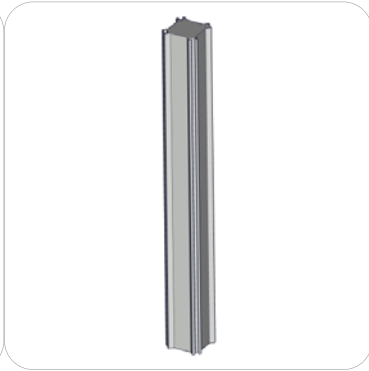

PM4D-600-TG x15

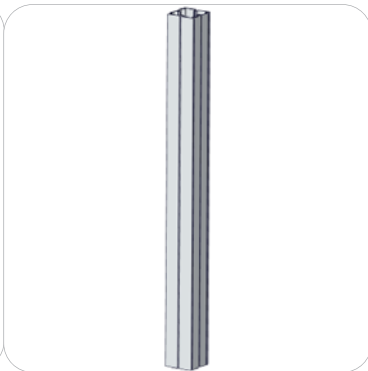

PM4S2-1200-A315-A315 x16



PM4S2-1200-A315-A315-GR x3



PM4S2-1200-A315-A315-GR x3



L180N-600 x20



L180N-1200 x10



L90S-900 x12



PL-DP-900-2400-SPLIT x1

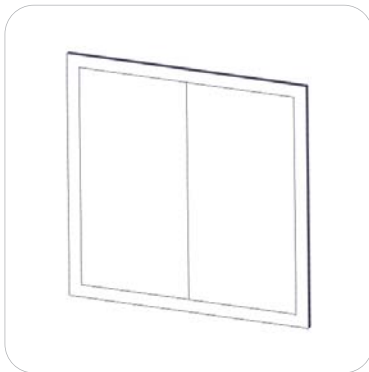

PL-CD-900-900 x3

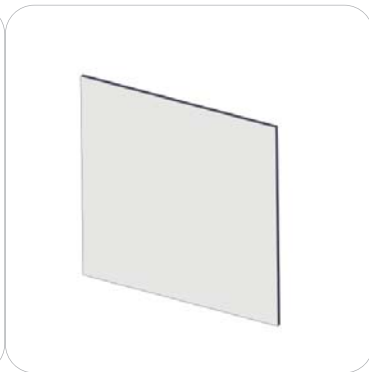

PL-900-600 x6

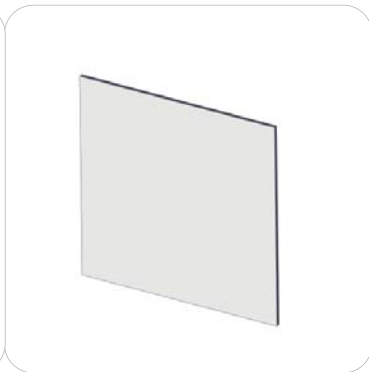

PL-900-900 x3

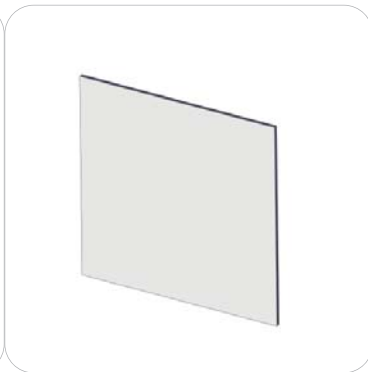

PL-1200-900 x2

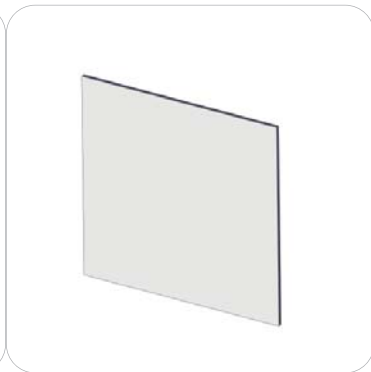

PL-1200-1200 x8

# Included In Your Kit

Tools, Components, & Connectors



HP-CT-1 x3



HP-CT-2 x3

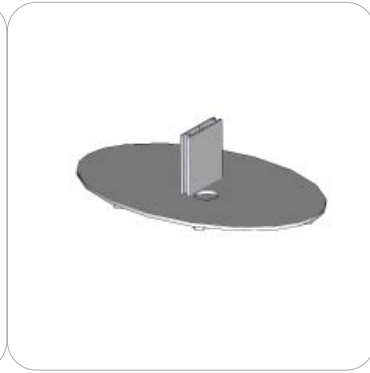

PLT-BP-PM4 x3

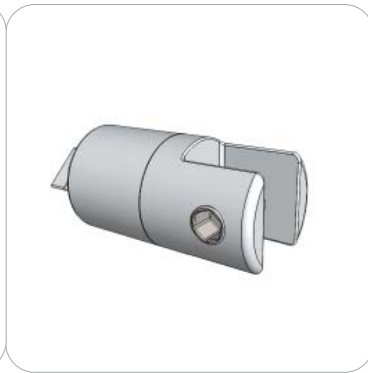

CKAPS x9



SS1-S x12

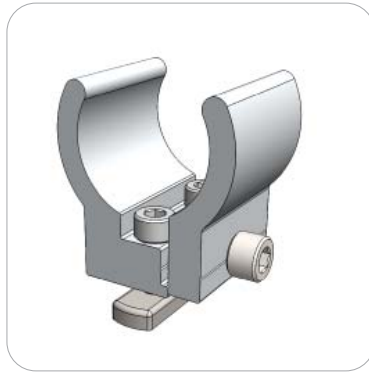

TC-30MM-SILVER-ASY-1 x16



PM4S2-900-L-L x2



PM4U-900-L-L x2



FC-2186 x4



FC-900-ROUTES x4



EXT-SM-MB x6



LUM-200-ORL x6



HP-FS-5 x2

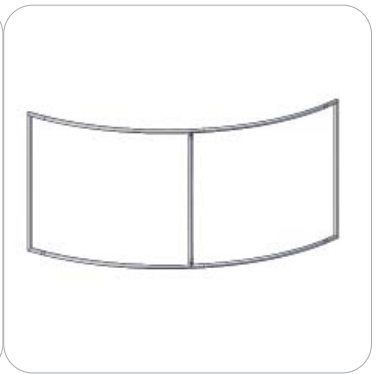

HP-FS-6 x2

# Included In Your Kit

Tools, Components, & Connectors



HP-FS-5-T1 x4



HP-FS-5-T2 x4



HP-FS-5-T3 x4



HP-FS-5-T4 x4



HP-FS-5-T5 x4



HP-FS-6-T1 x4



HP-FS-6-T2 x2



HP-FS-6-T3 x2



HP-FS-6-T4 x4



HP-FS-6-T5 x2

# Included In Your Kit



HP-17-A-G x1



HP-17-B-G x1



HP-17-C-G x1

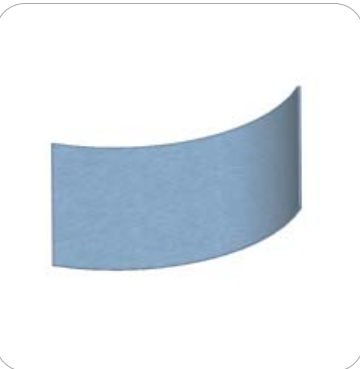

HP-17-D-G x1

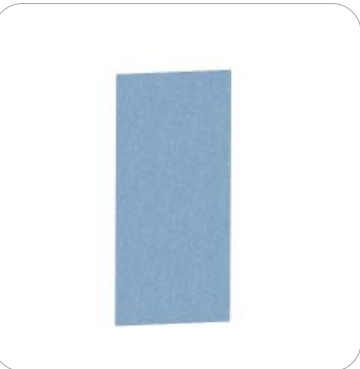

HP-17-E-G x1

Graphics



HP-17-F-G x1



HP-17-G-G x1



HP-17-H-G x1



HP-17-I-G x1

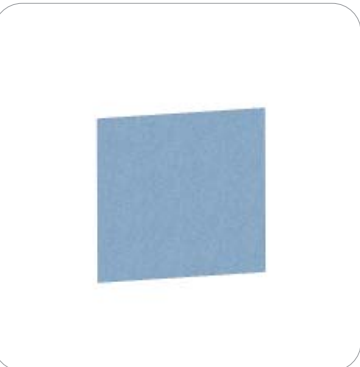

HP-17-J-G x1

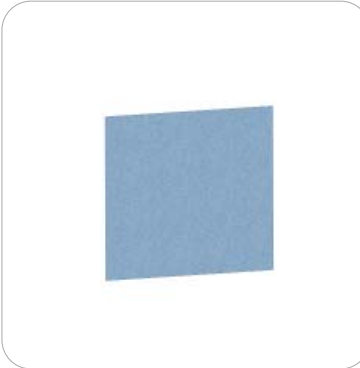

HP-17-K-G x1

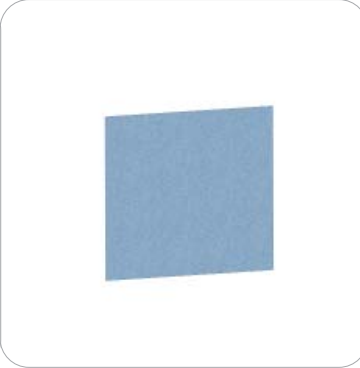

HP-17-L-G x1



HP-17-M-G x1



HP-17-N-G x1

# Exploded View

HP-K-17

Section 1.1

Reference the Suggested Layout page for build location.

— Loop velcro

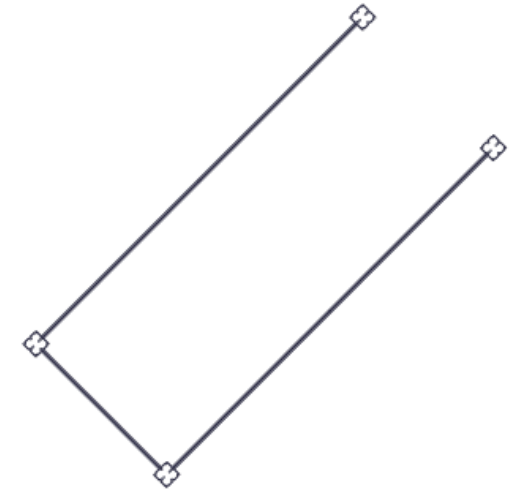
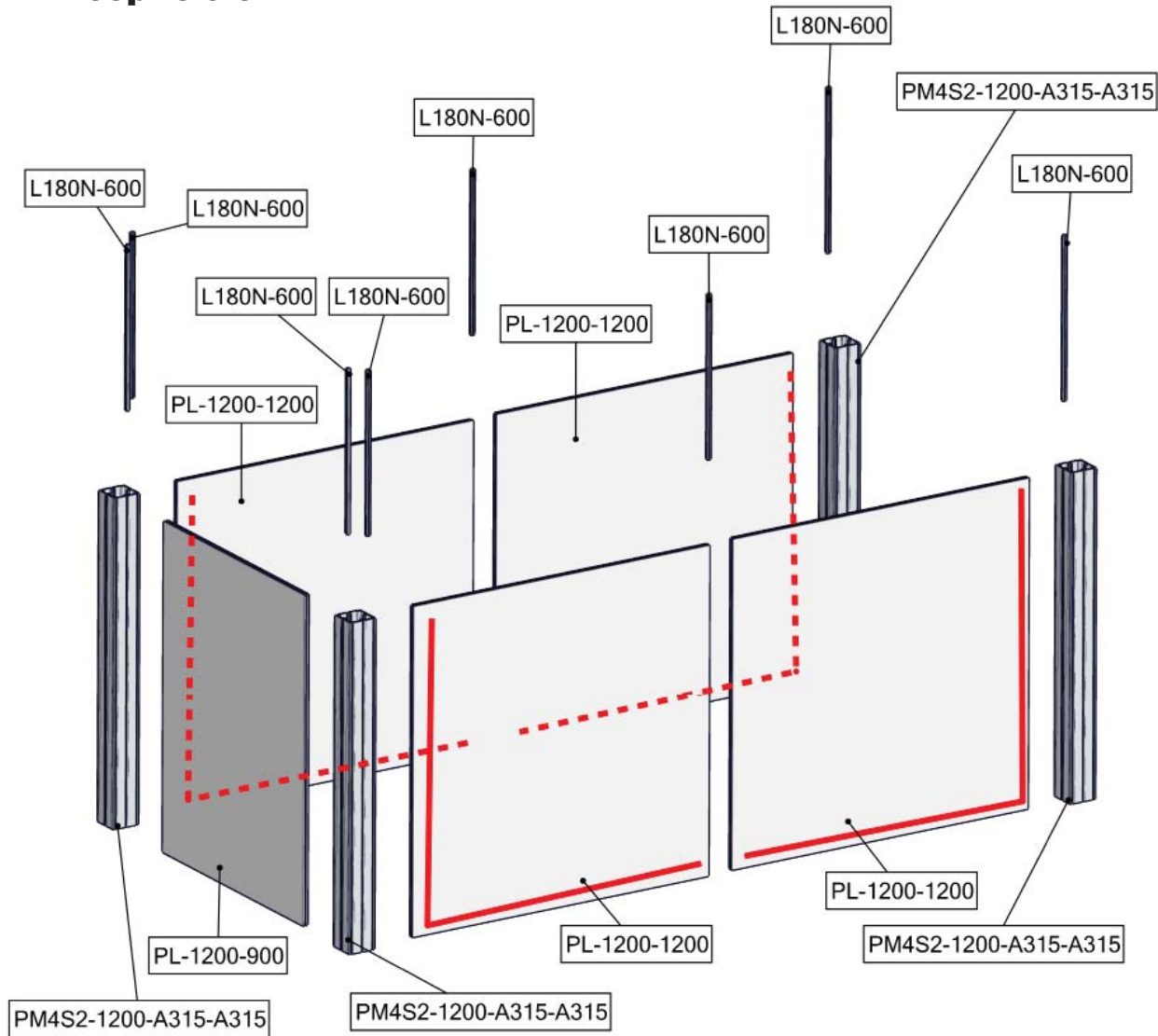

# Exploded View

HP-K-17

Section 1.2

Reference the Suggested Layout page for build location.

— **Loop velcro**

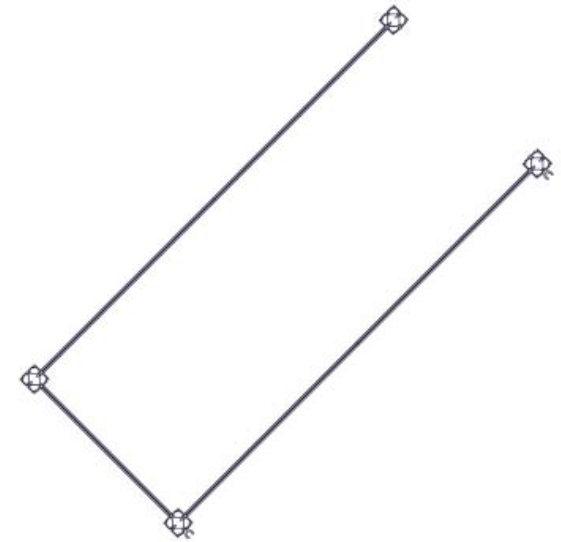
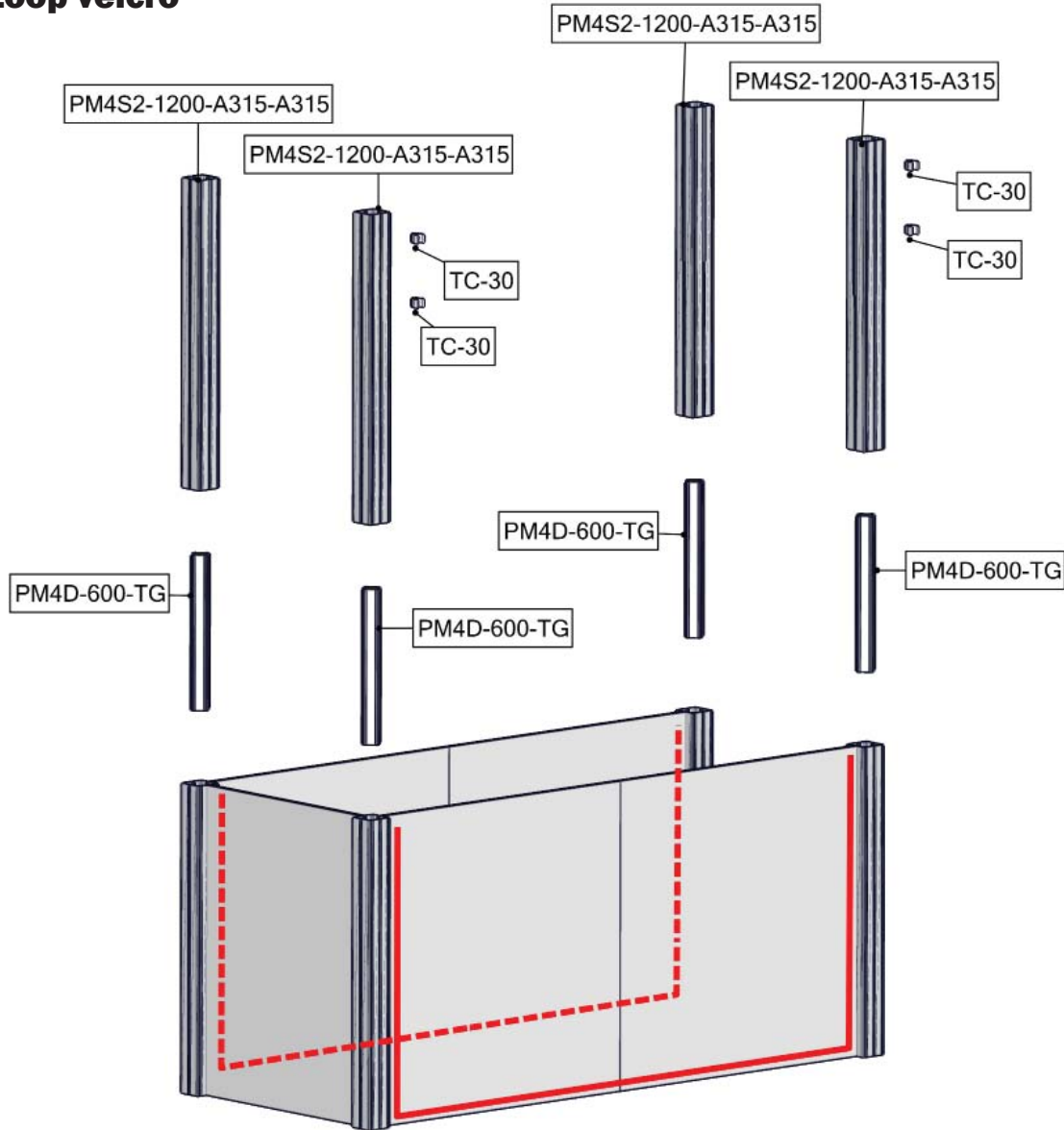

# Exploded View

HP-K-17

Section 1.3

Reference the Suggested Layout page for build location.

— **Loop velcro**

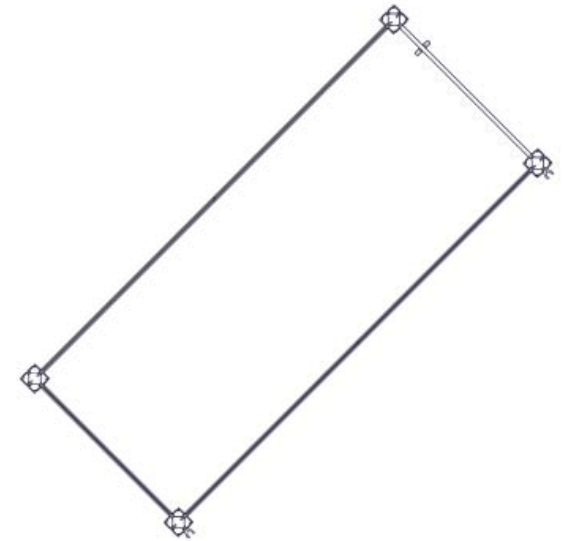
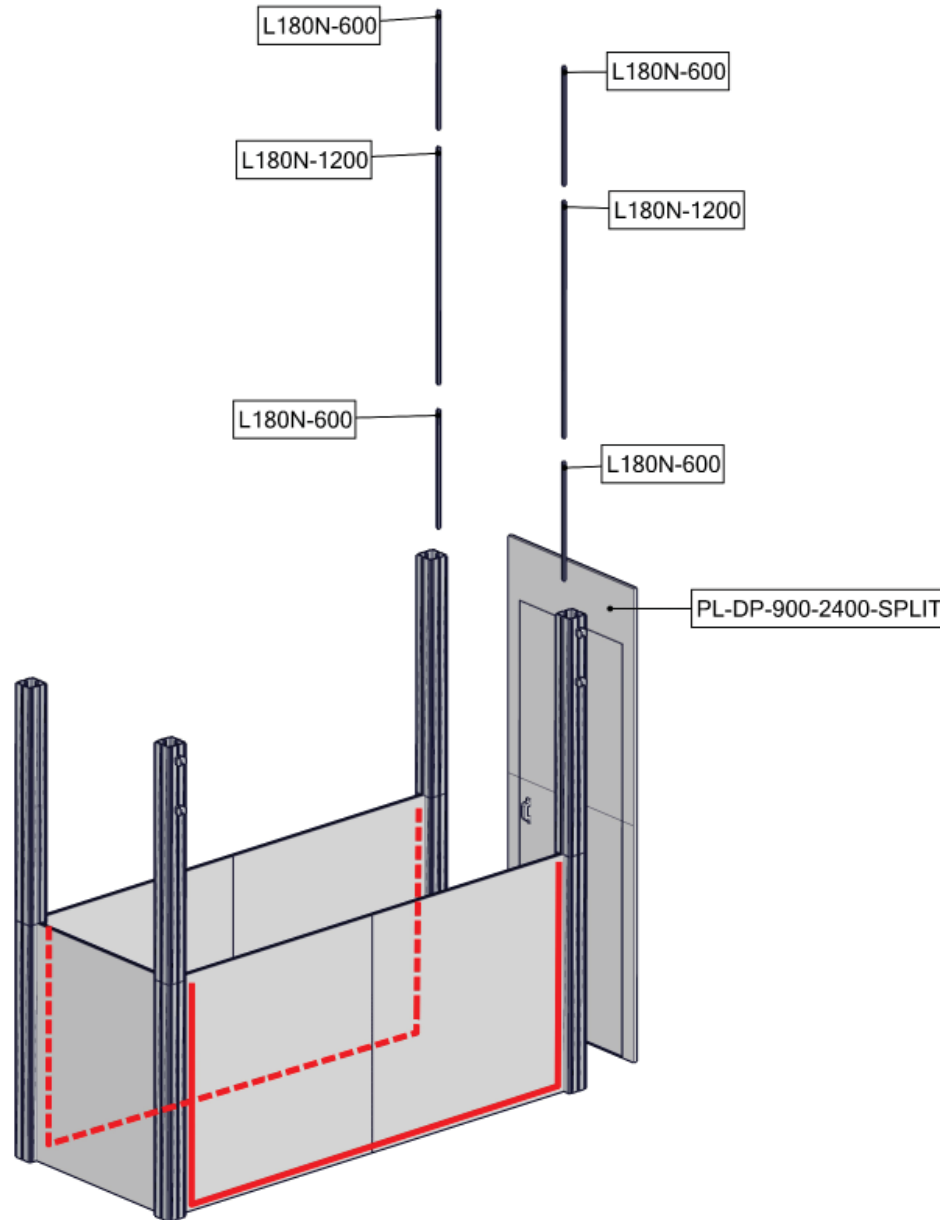



# Exploded View

HP-K-17

Section 1.4

Reference the Suggested Layout page for build location.

— **Loop velcro**

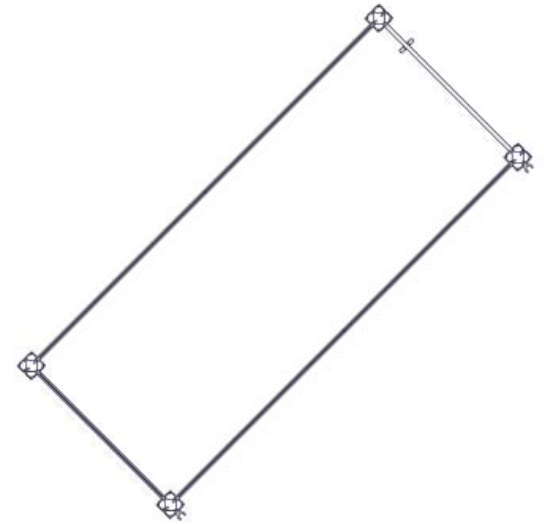
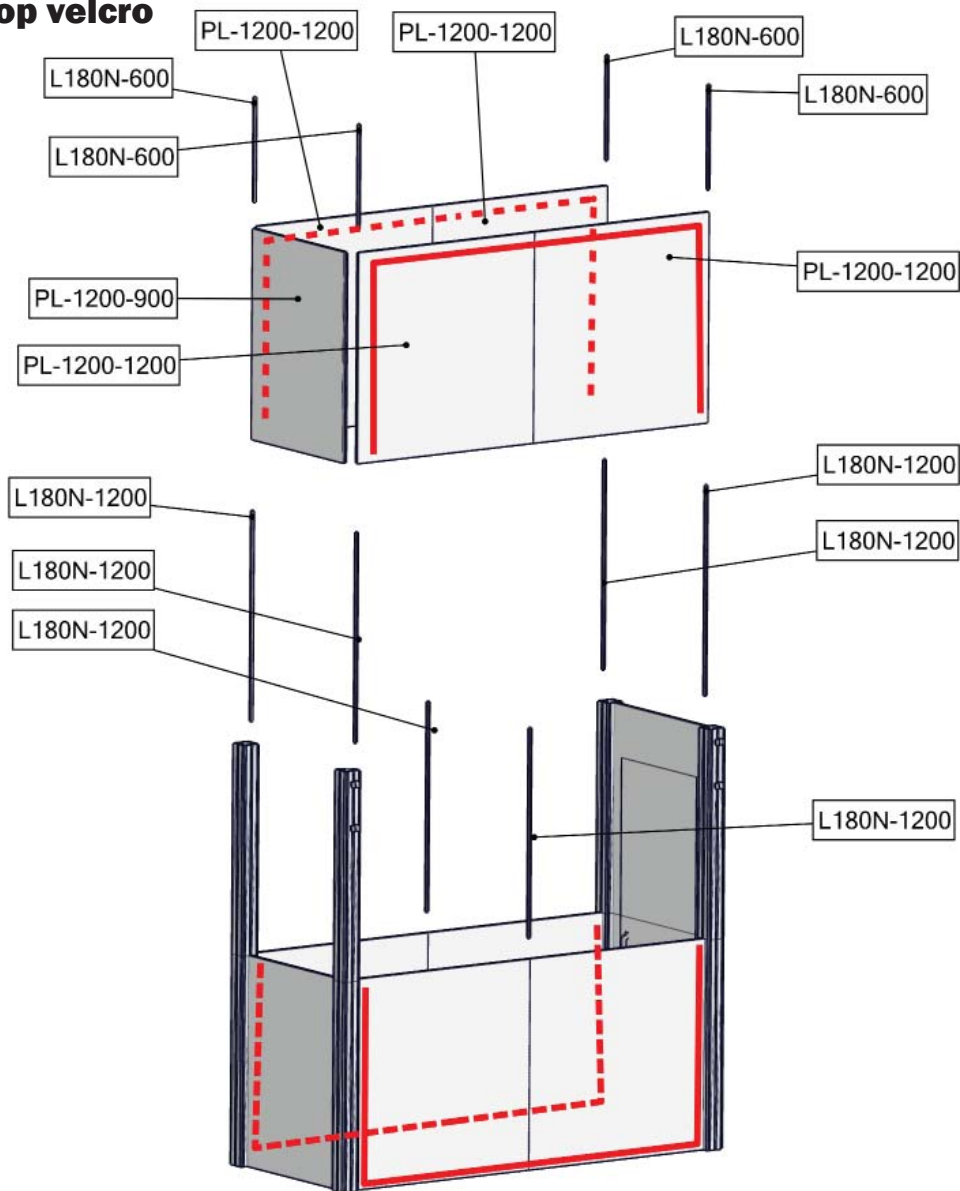

# Exploded View

HP-K-17

Section 1.5

Reference the Suggested Layout page for build location.

— **Loop velcro**

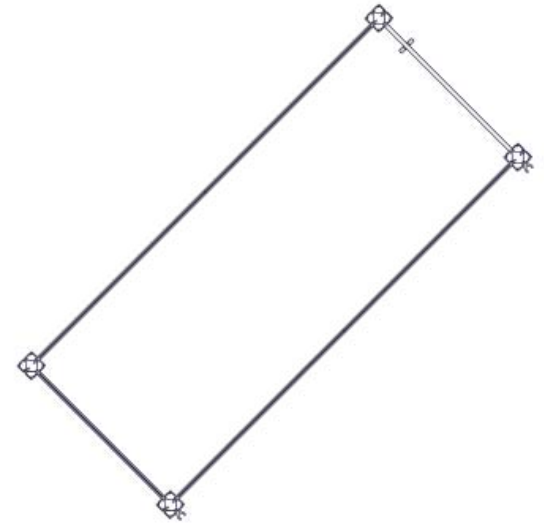
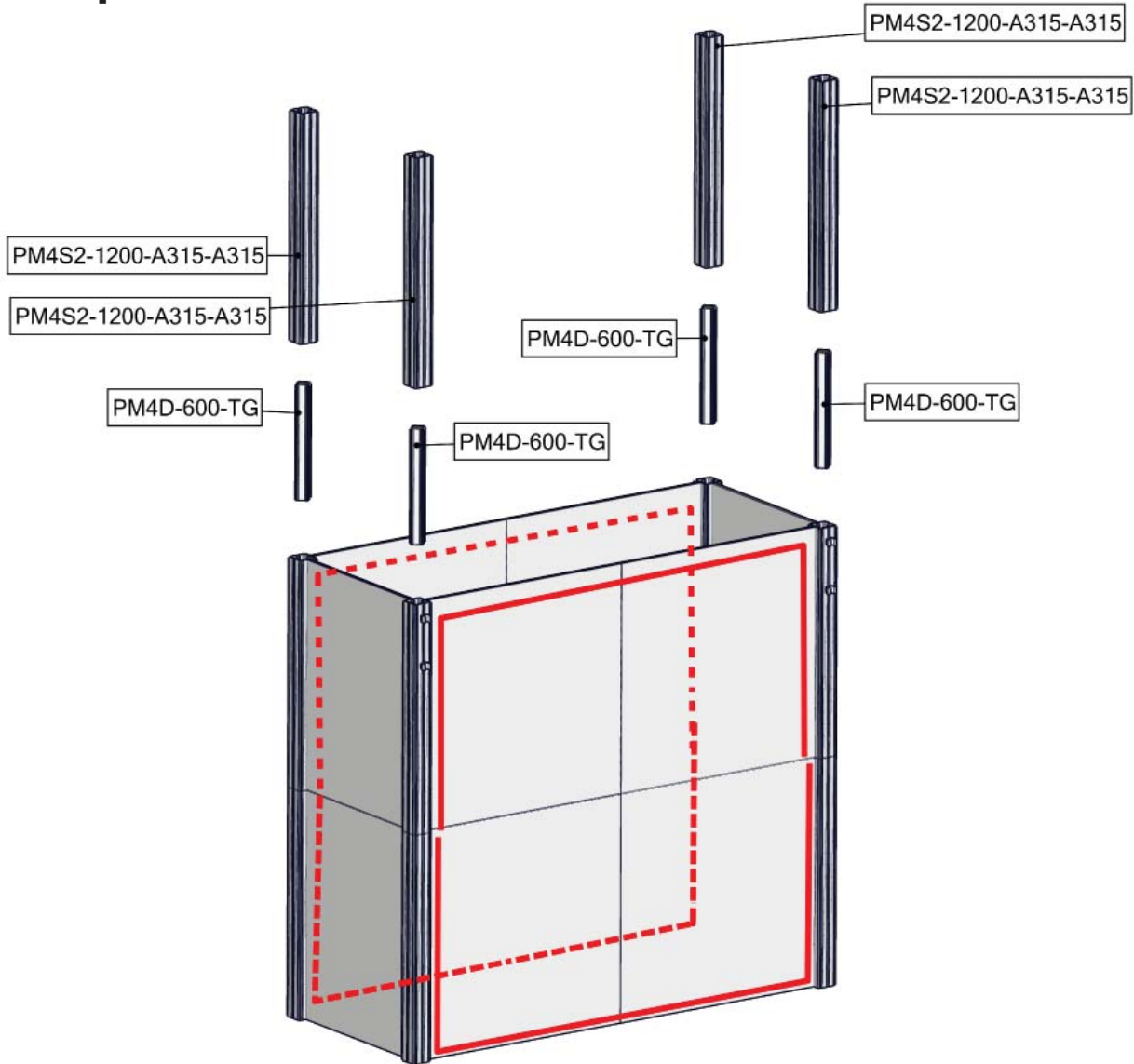

# Exploded View

HP-K-17

Section 1.6

Reference the Suggested Layout page for build location.

— **Loop velcro**

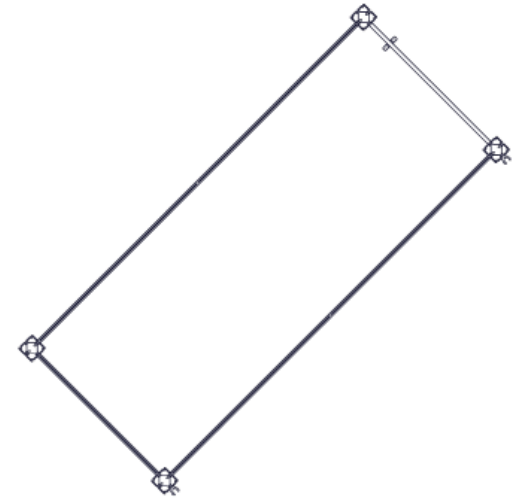
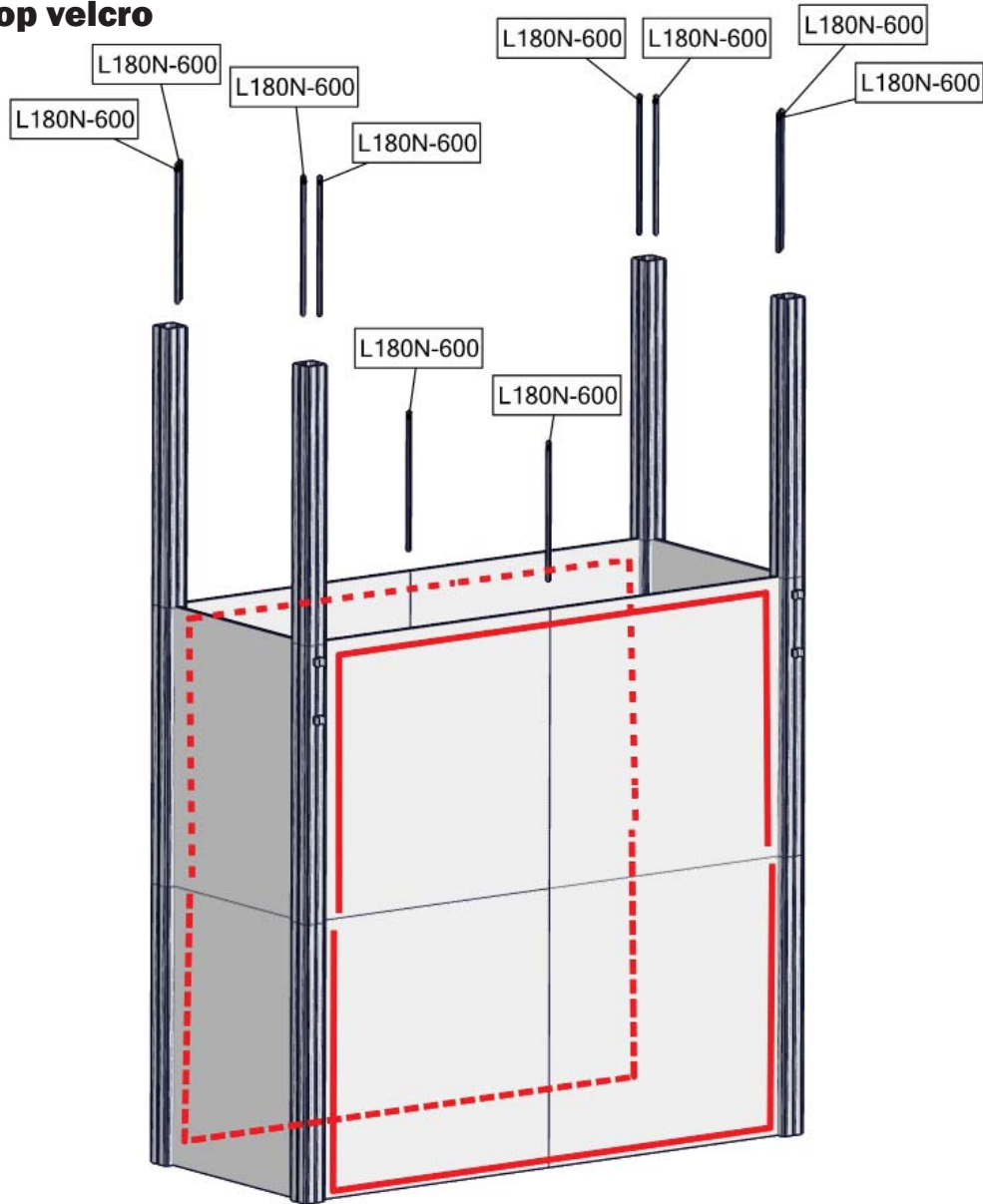

# Exploded View

HP-K-17

Section 1.7

Reference the Suggested Layout page for build location.

— **Loop velcro**

FC-900-ROUTES

PM4S2-900-L-L

FC-900-ROUTES

PM4S2-900-L-L

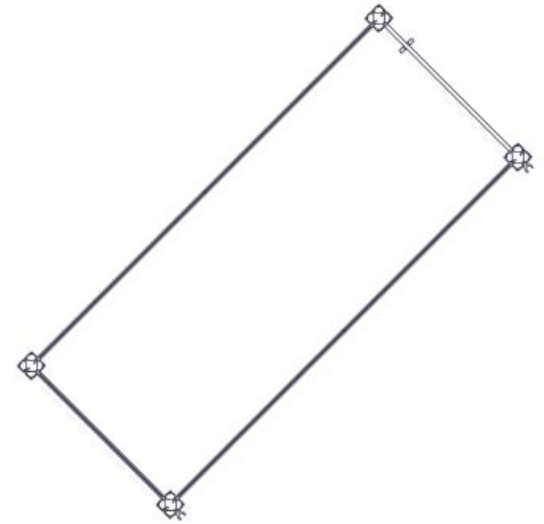
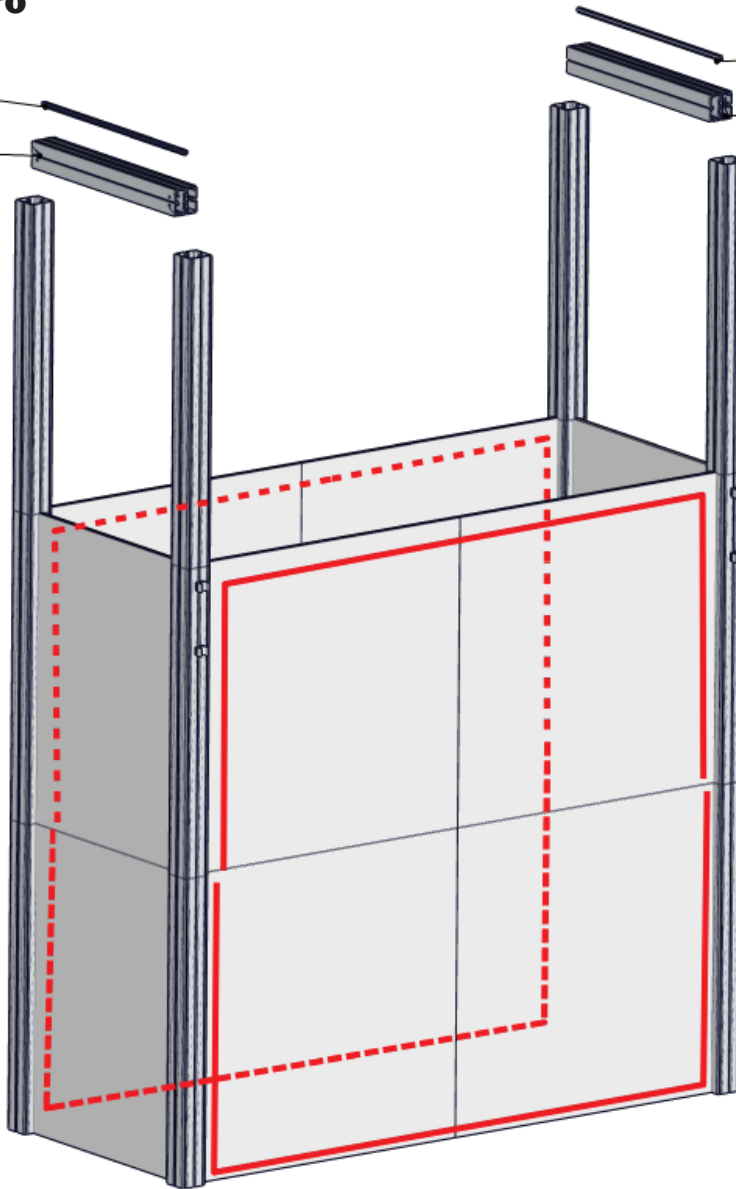

# Exploded View

HP-K-17

Section 1.8

Reference the Suggested Layout page for build location.

— **Loop velcro**

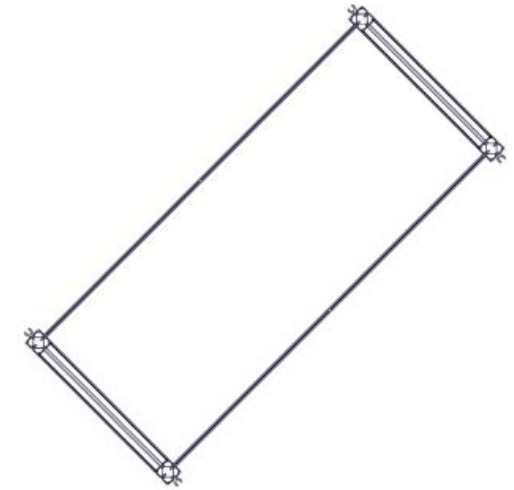
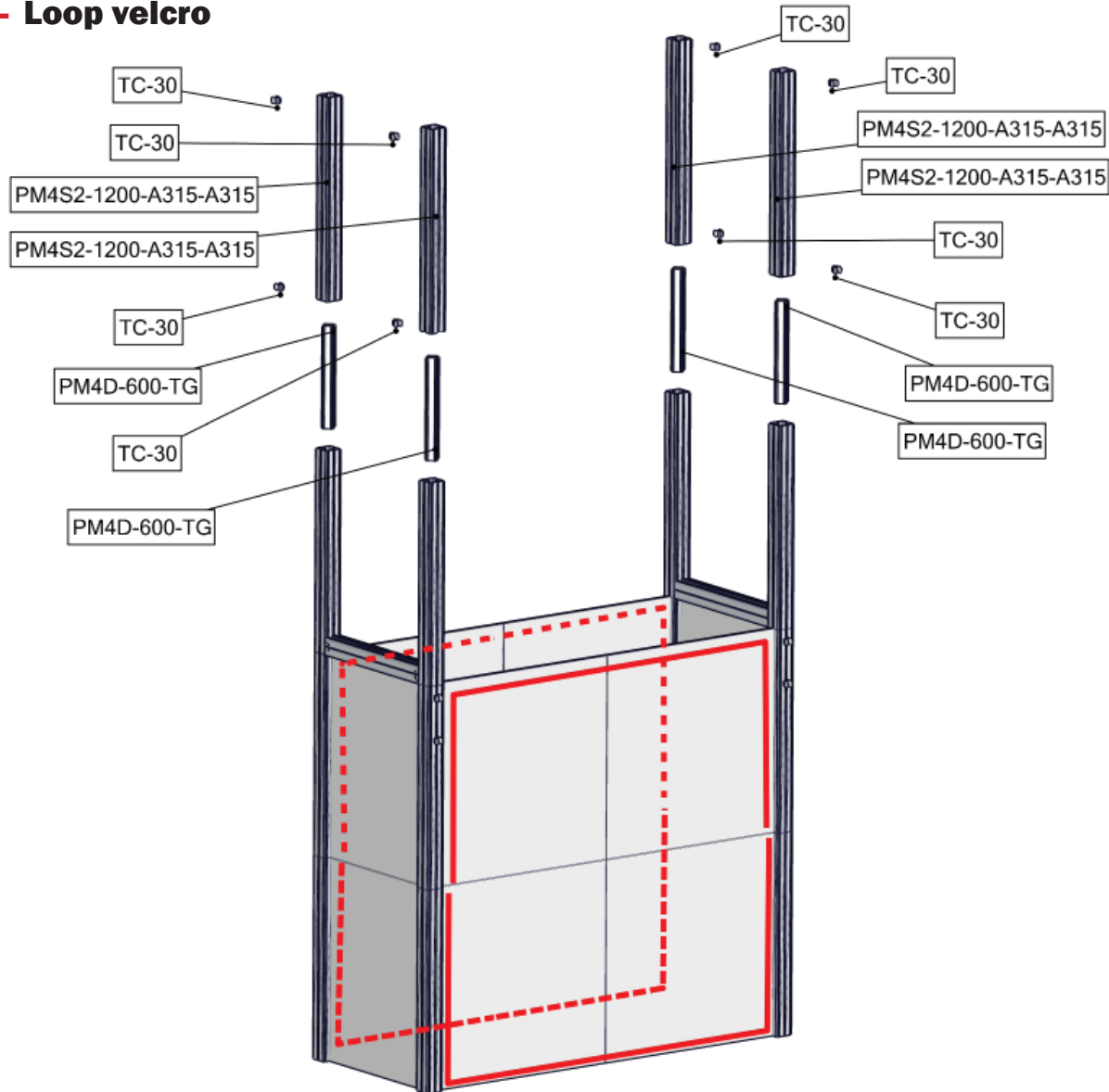

# Exploded View

HP-K-17

Section 1.9

Reference the Suggested Layout page for build location.

— **Loop velcro**

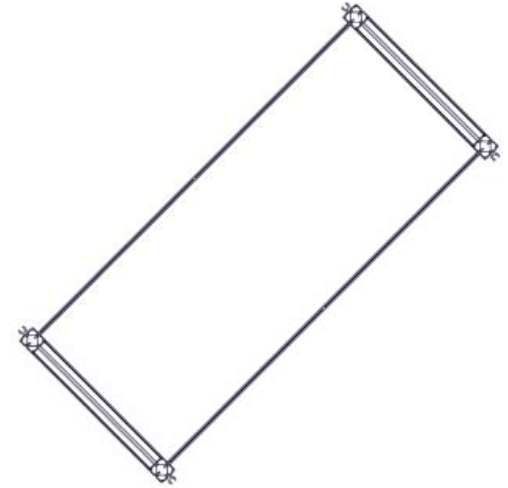
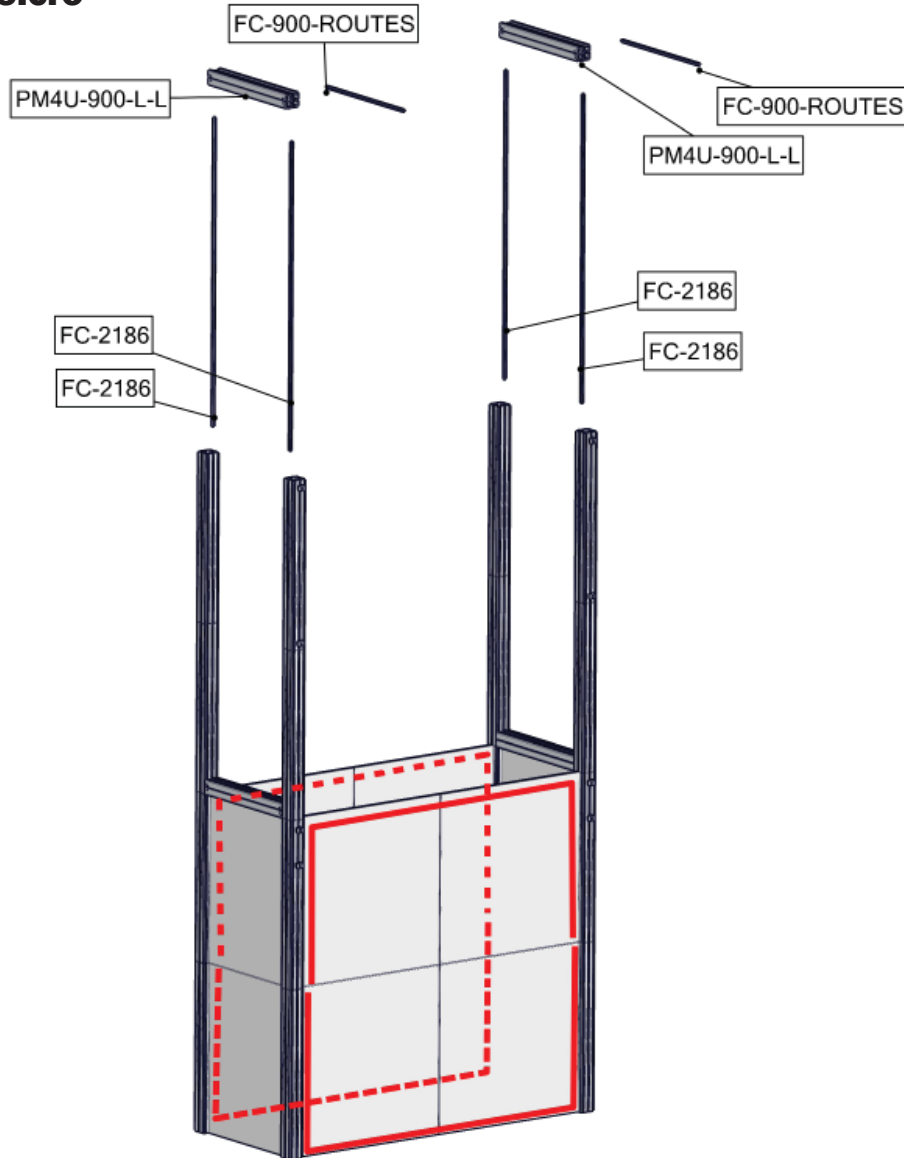

# Exploded View

HP-K-17

Section 1.10 HP-FS-6

Reference the Suggested Layout page for build location.

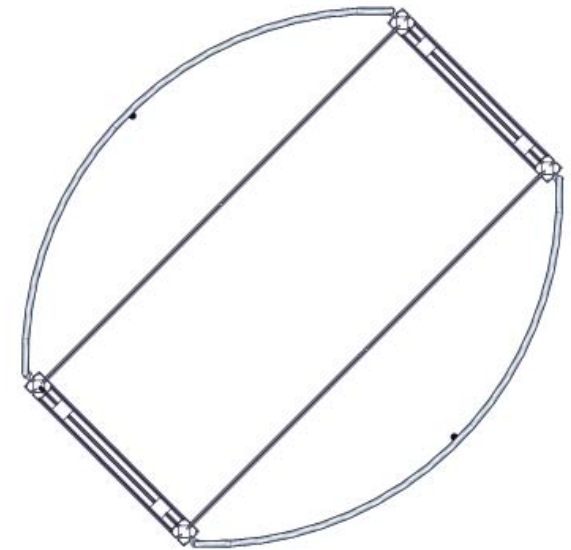
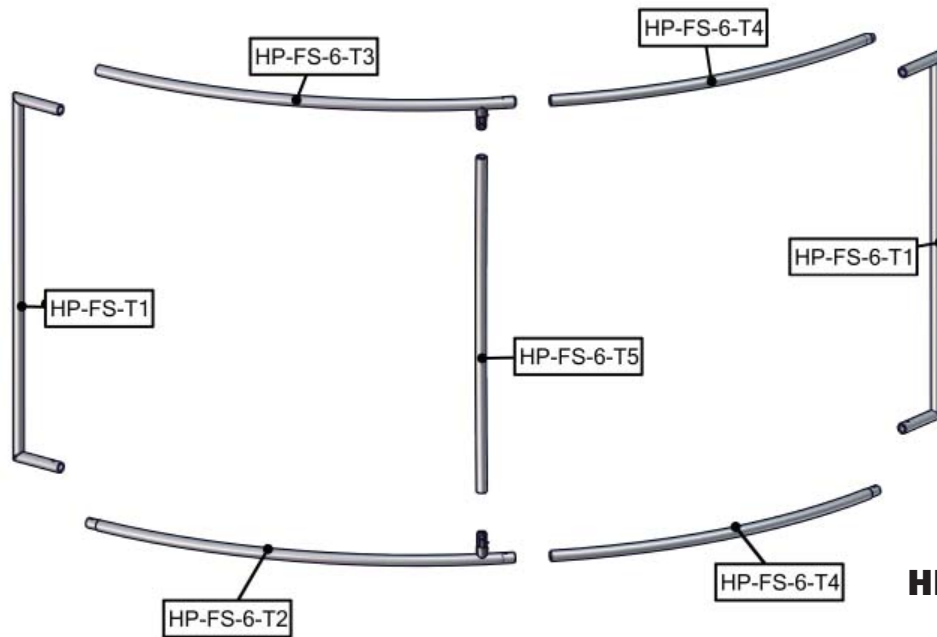

**HP-17-D-G**

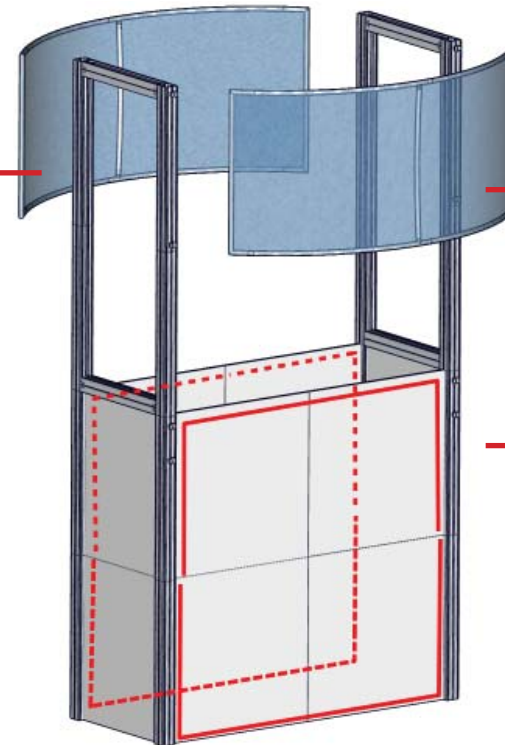

**HP-17-C-G**

**DOOR SIDE**

# Labeling Diagram

HP-K-17

Section 1.10 HP-FS-6

Reference the Suggested Layout page for build location.

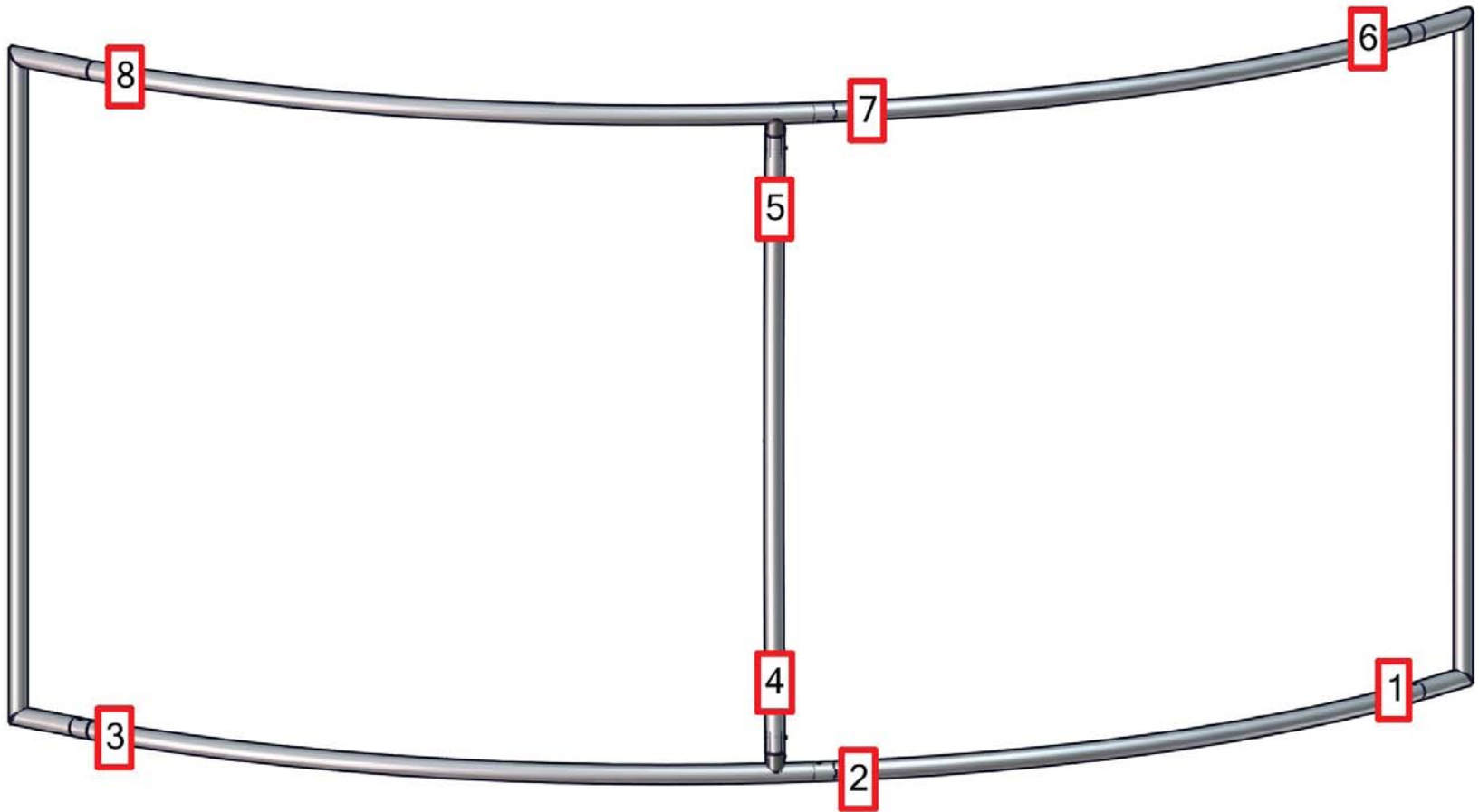



# Exploded View

HP-K-17

Section 1.11

Reference the Suggested Layout page for build location.

## — Loop velcro

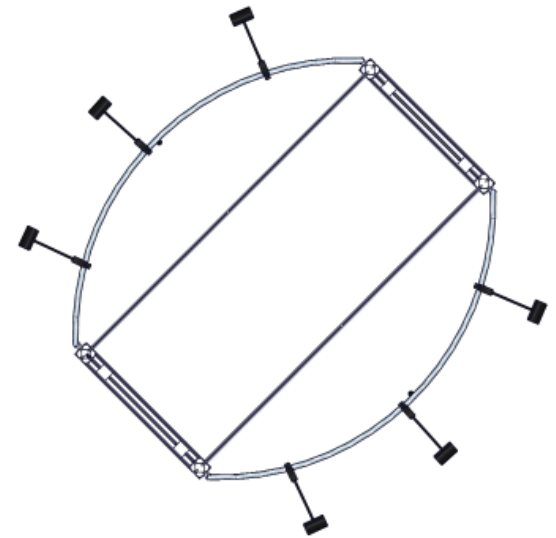
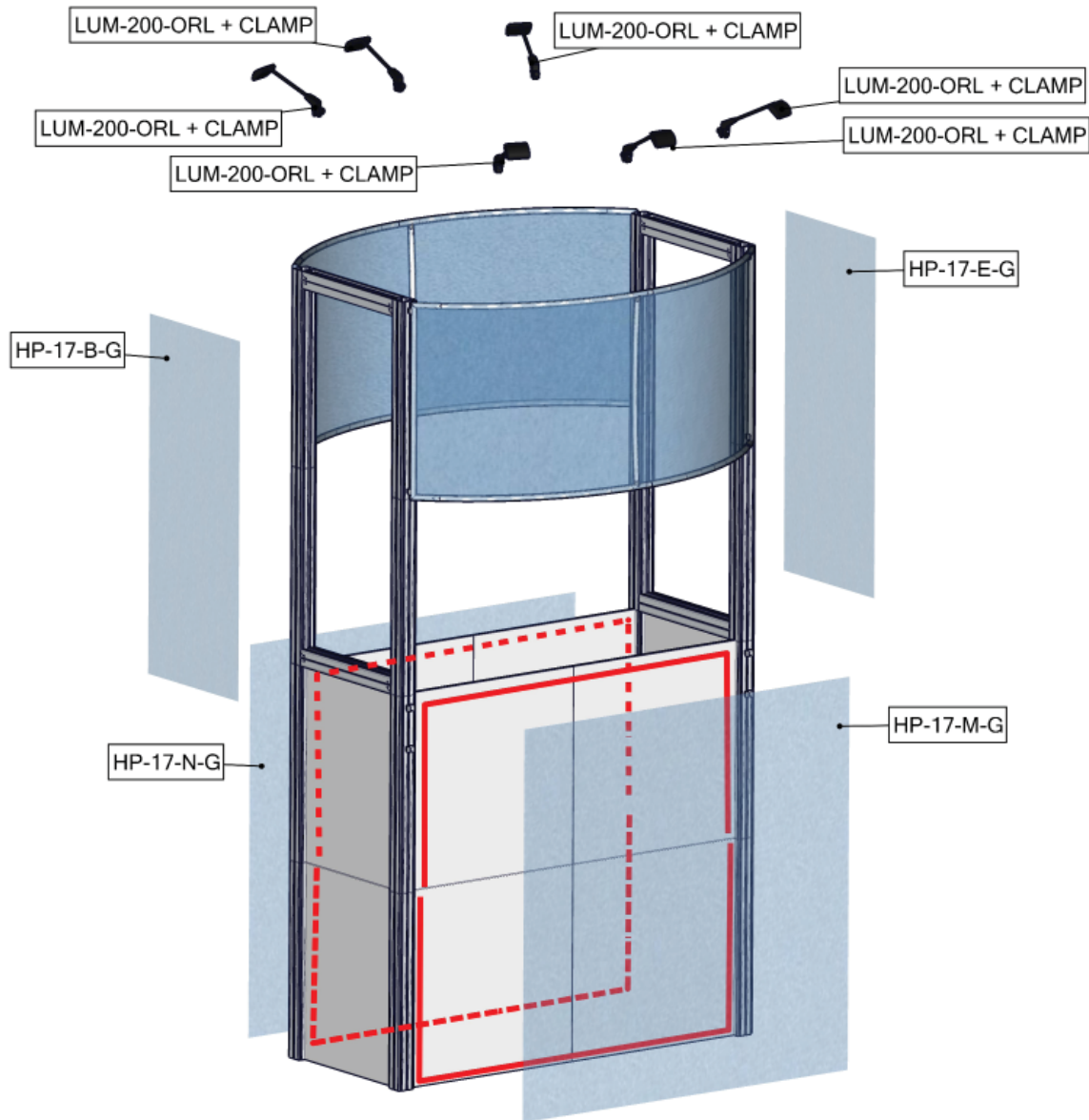

# Exploded View

HP-K-17

Section 2.1 Counter 1, 2 & 3

Reference the Suggested Layout page for build location.

— **Loop velcro**

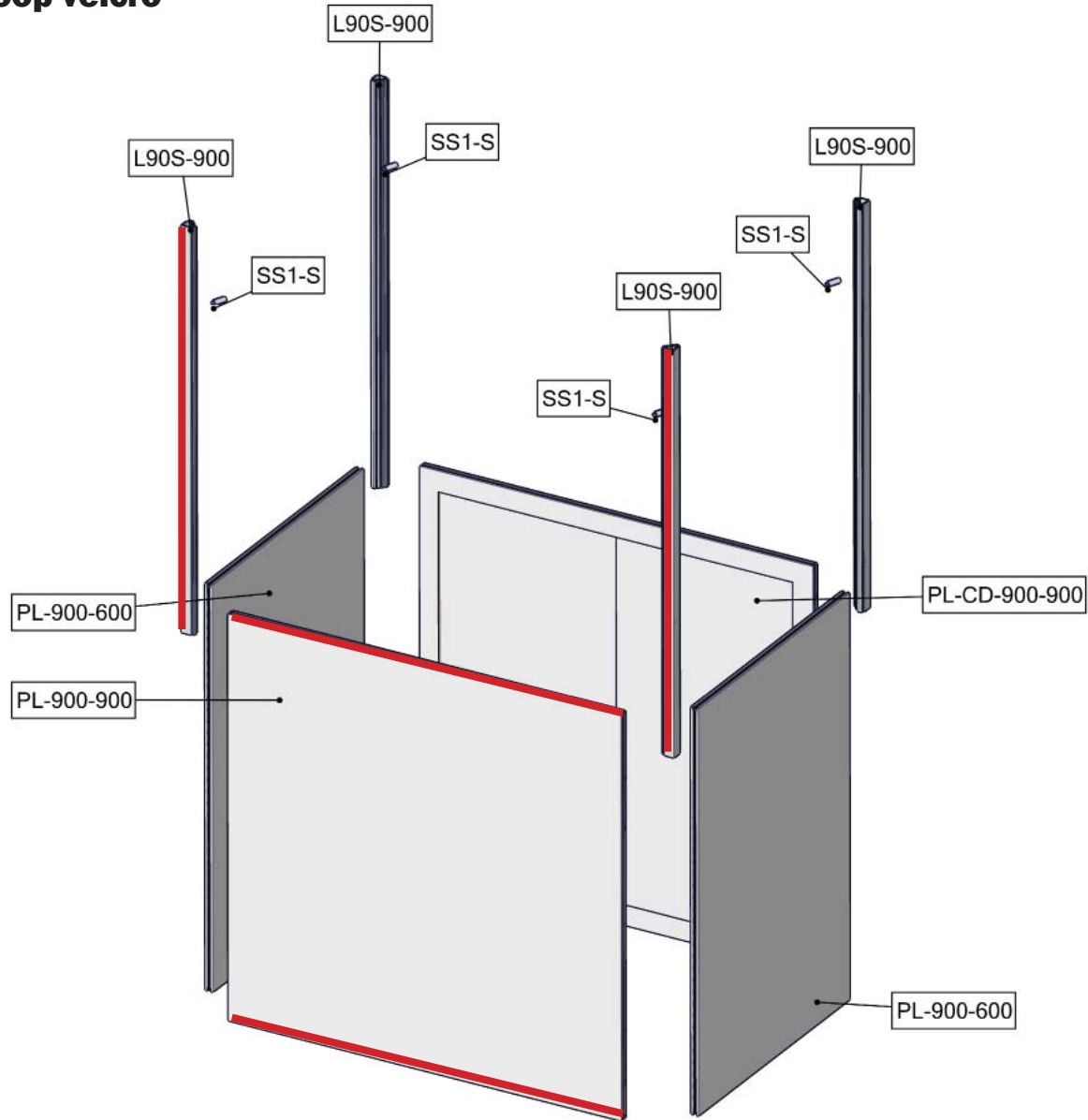

# Exploded View

HP-K-17

Section 2.2 Counter 1, 2 & 3

Reference the Suggested Layout page for build location.

— **Loop velcro**

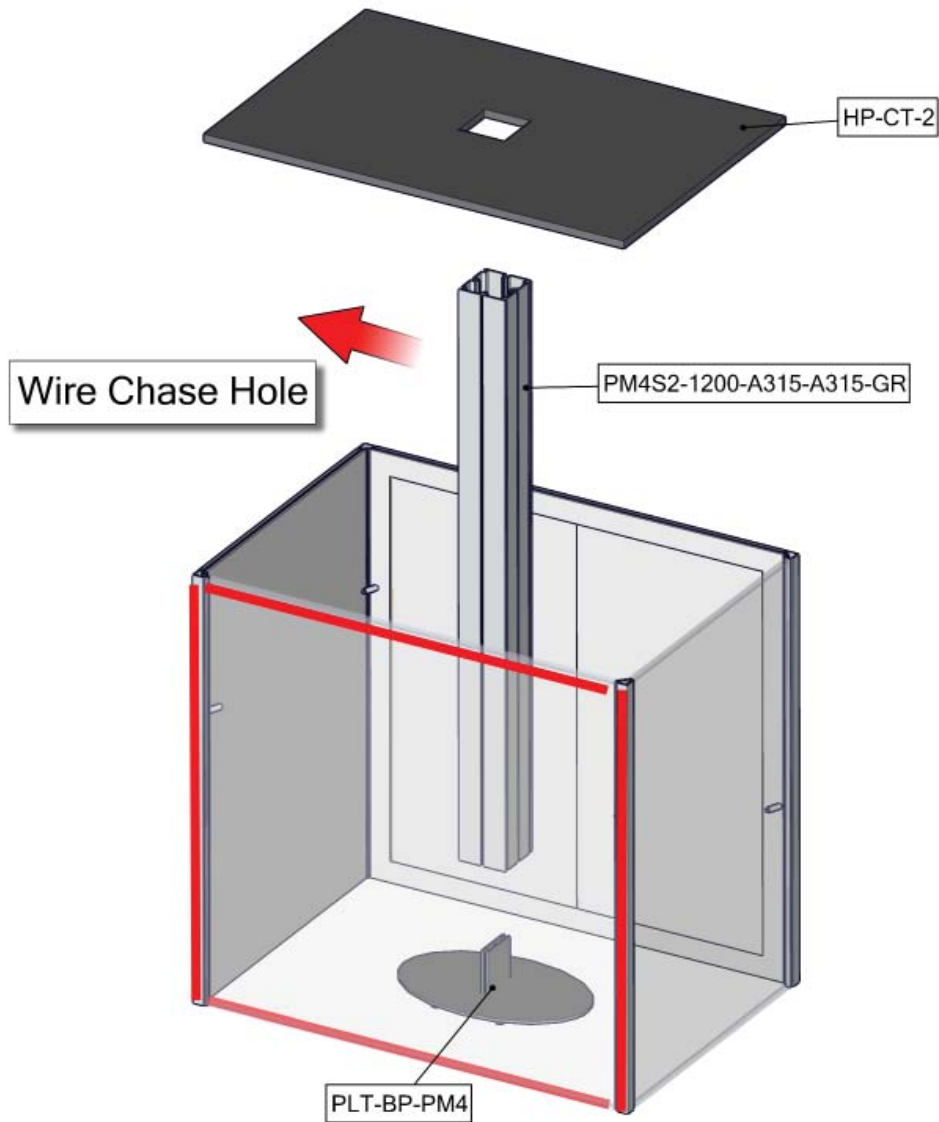

# Exploded View

HP-K-17

Section 2.3 Counter 1, 2 & 3

Reference the Suggested Layout page for build location.

— **Loop velcro**

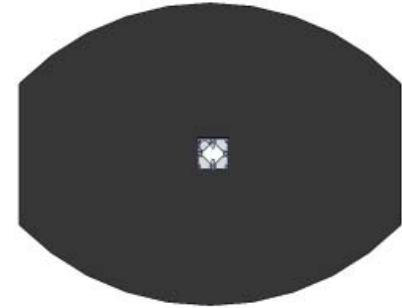
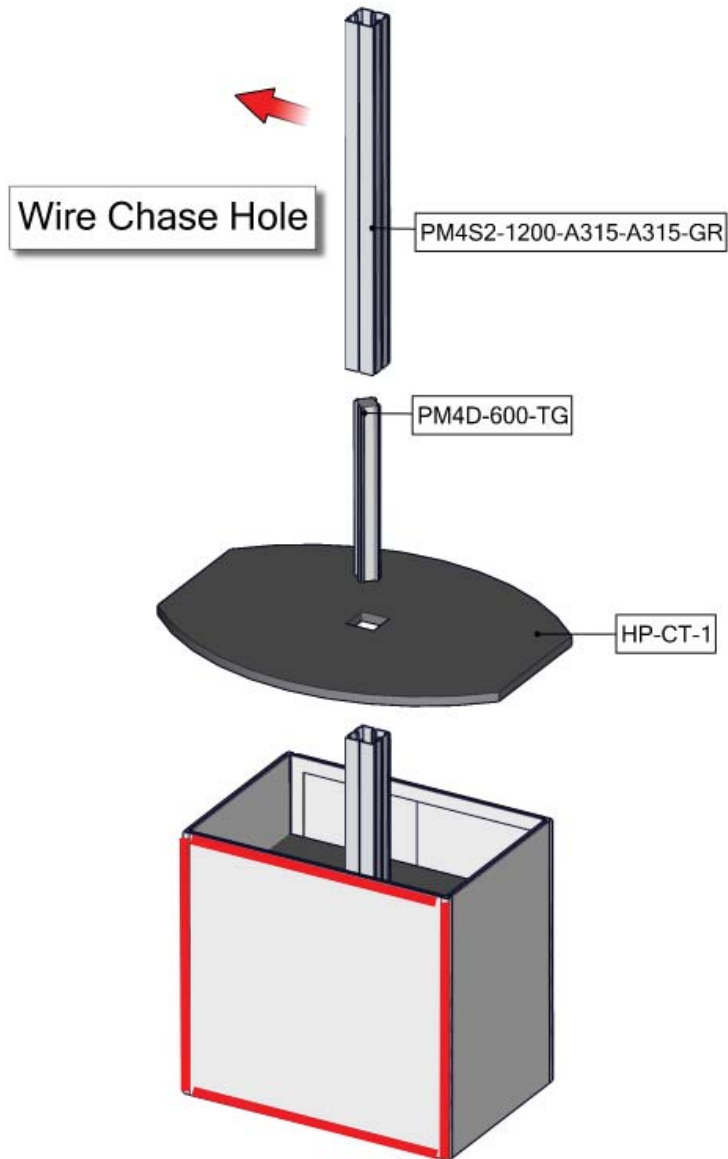

# Exploded View

HP-K-17

Section 2.4 Counter 1

Reference the Suggested Layout page for build location.

— **Loop velcro**

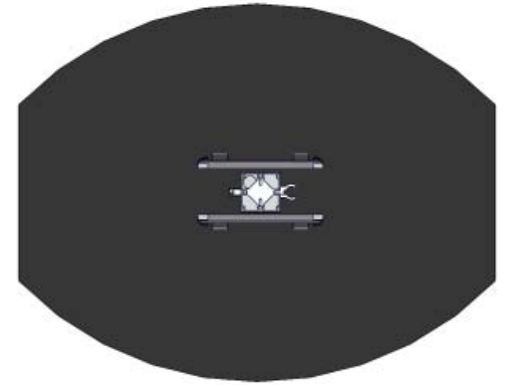
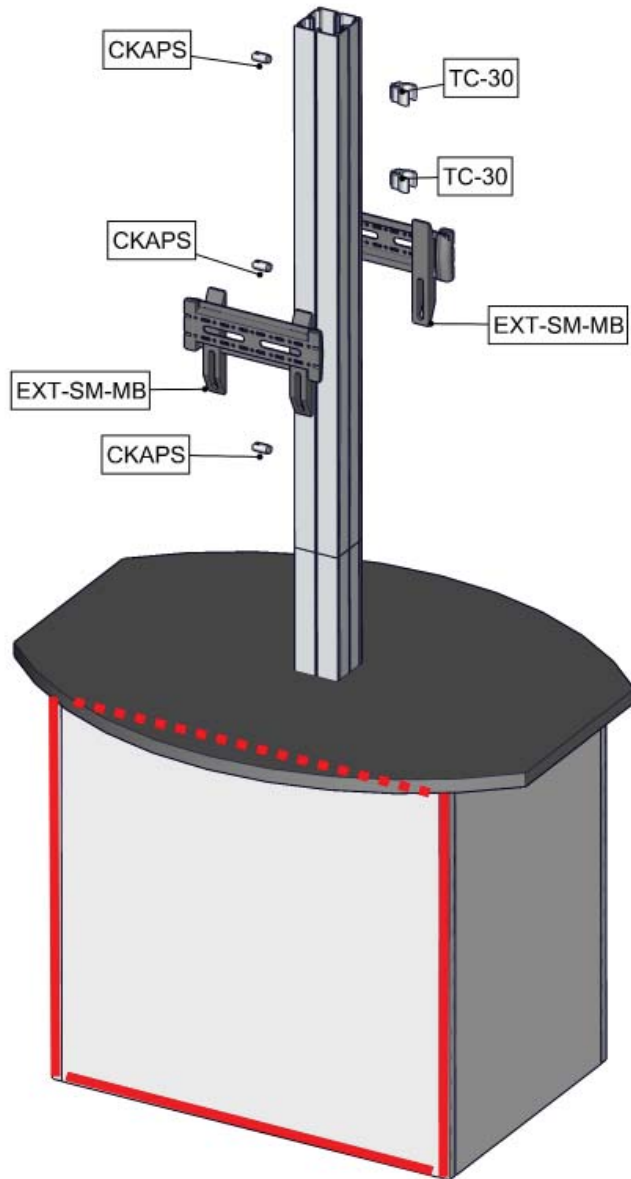

# Exploded View

HP-K-17

Section 2.5 Counter 2

Reference the Suggested Layout page for build location.

— **Loop velcro**

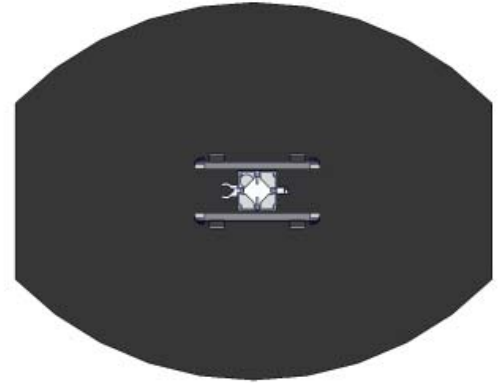
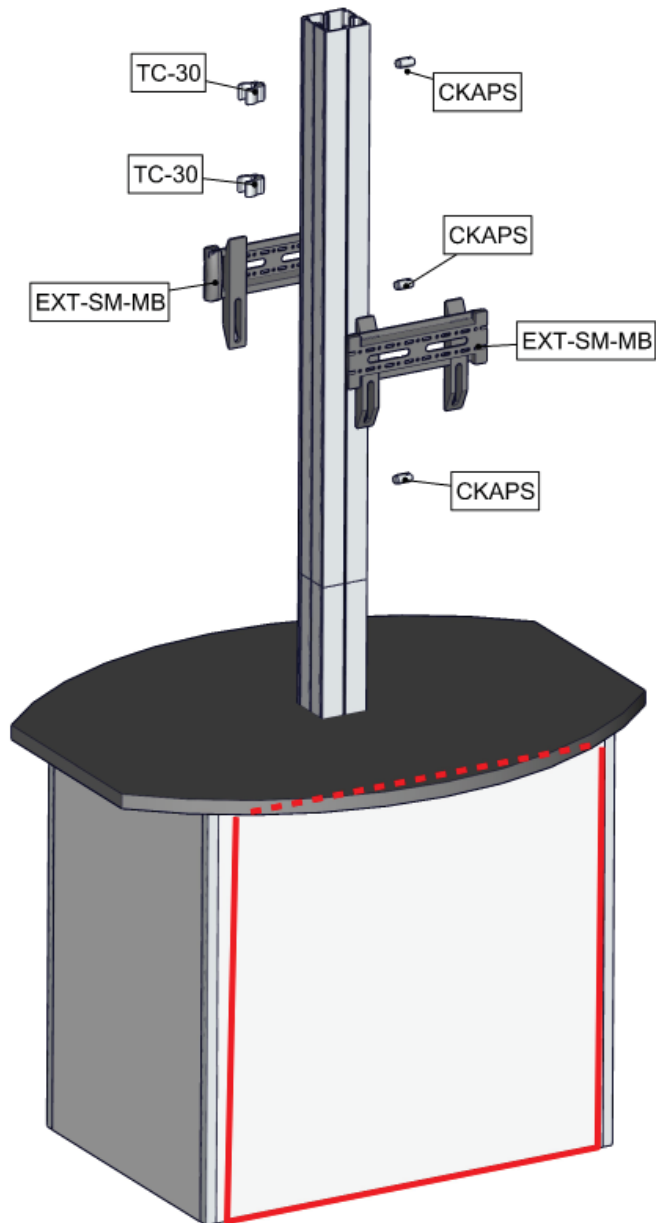

# Exploded View

HP-K-17

Section 2.6 Counter 3

Reference the Suggested Layout page for build location.

— Loop velcro

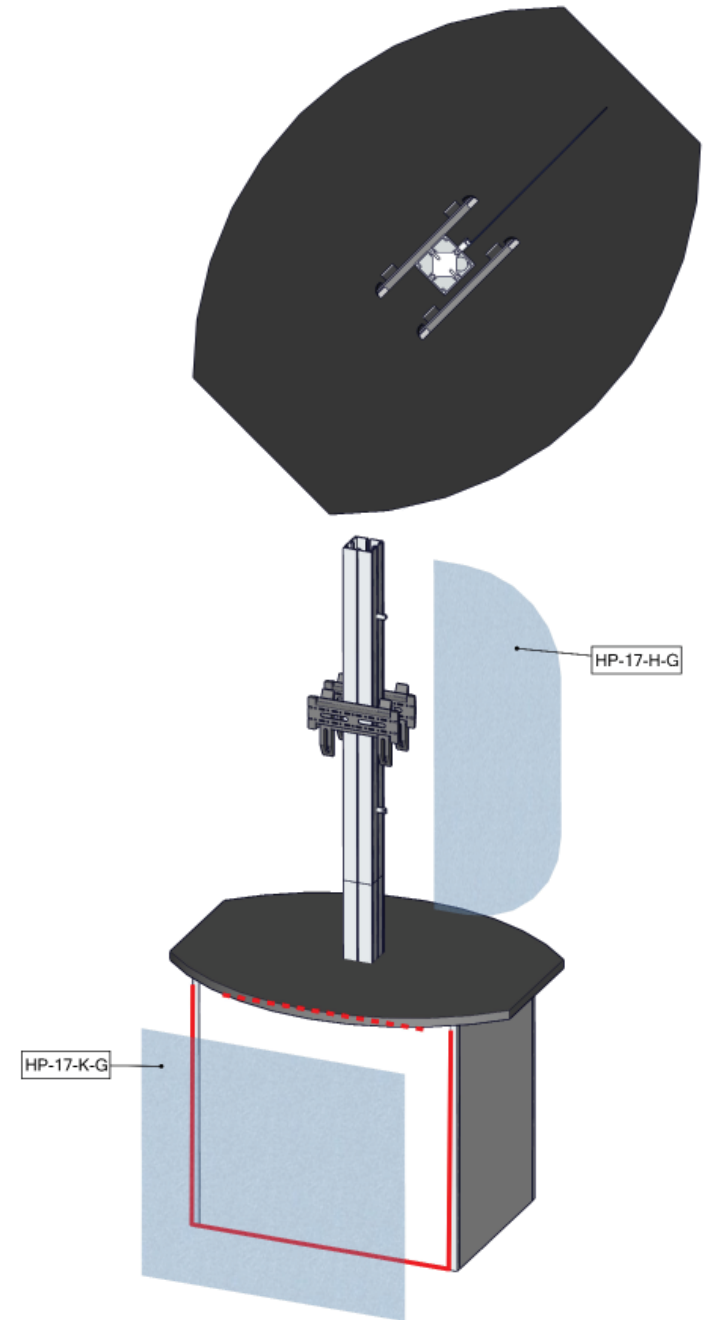
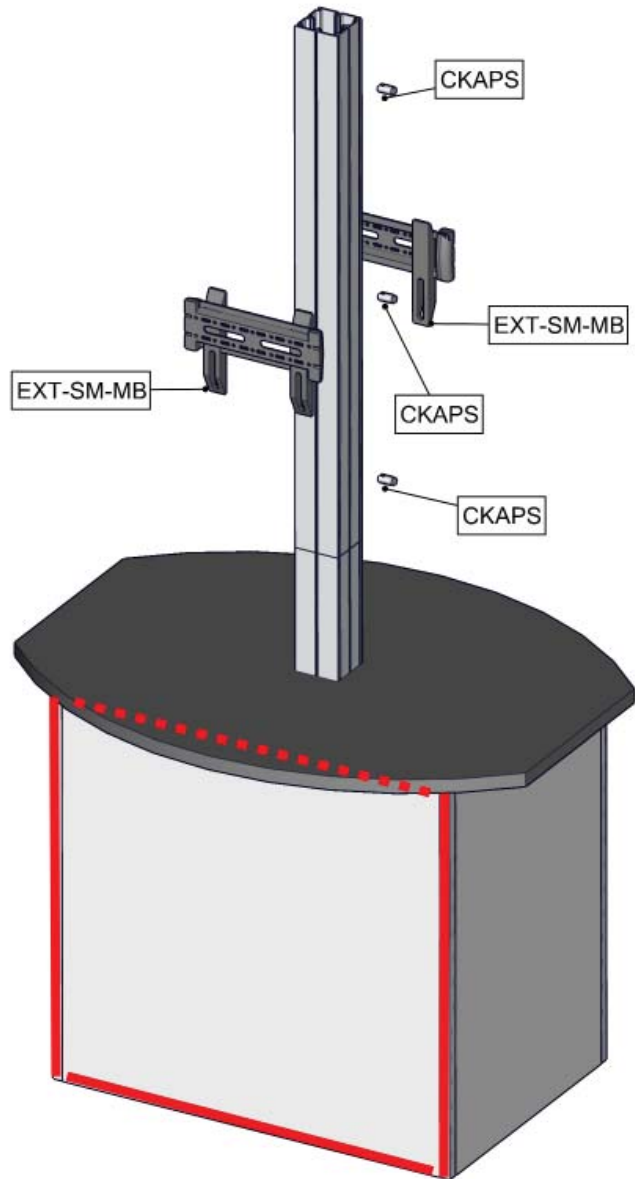

# Exploded View

HP-K-17

Section 3.1 HP-FS-5

Reference the Suggested Layout page for build location.

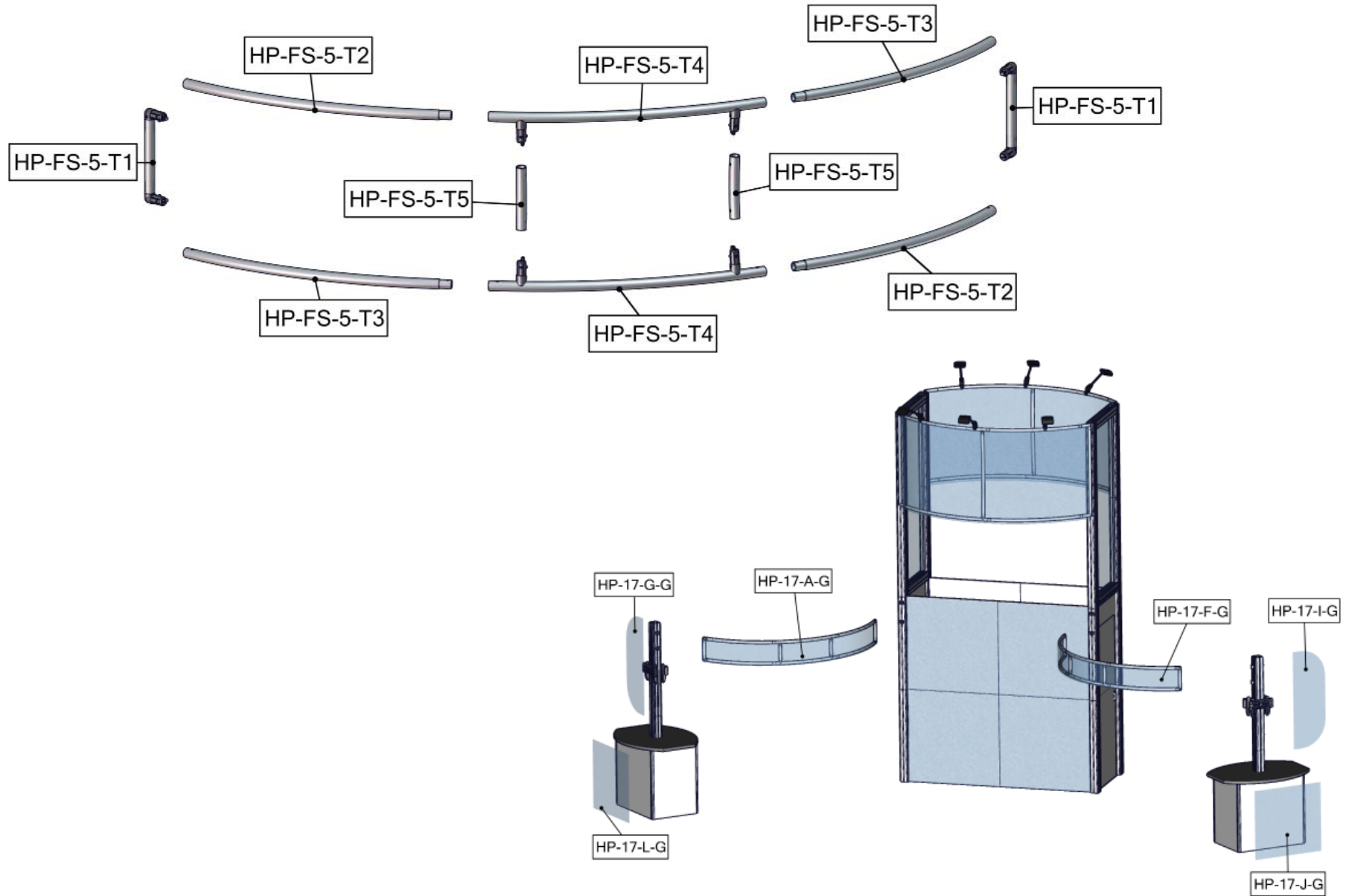



# Labeling Diagram

HP-K-17

Section 3.1 HP-FS-5

Reference the Suggested Layout page for build location.

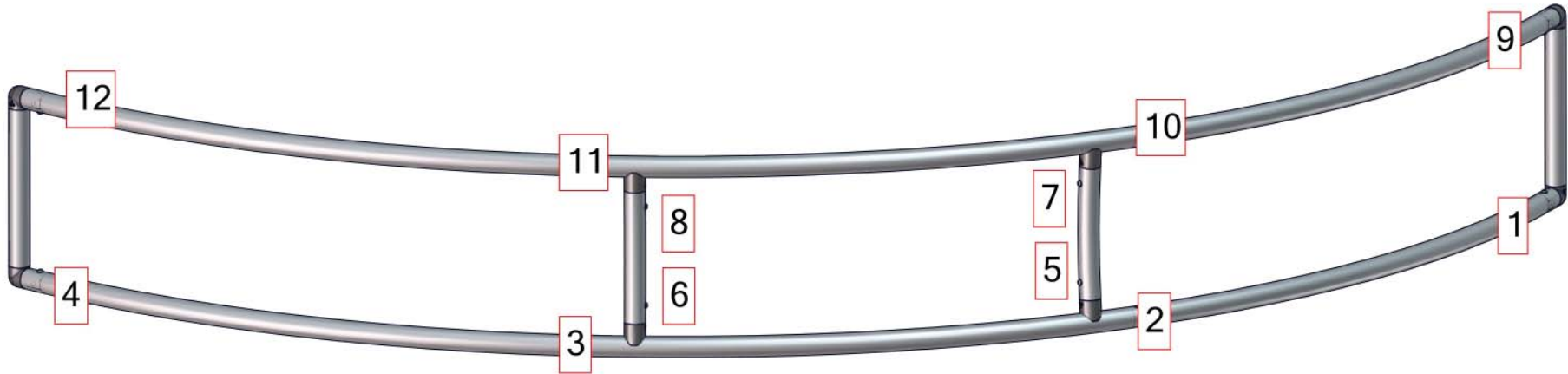

# Suggested Layout

HP-K-17

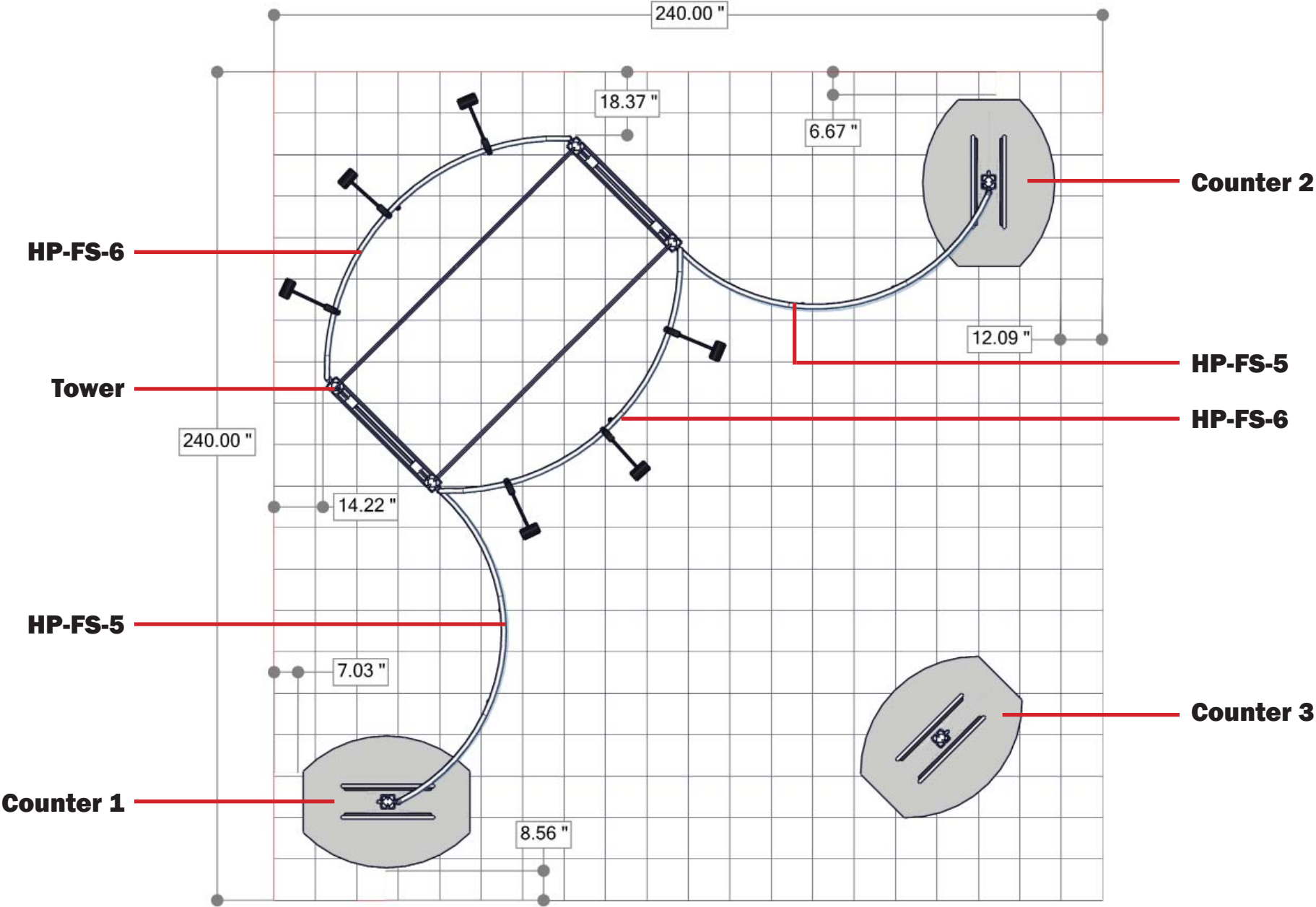

# Connection Methods

## Connection Method 1: LN180N

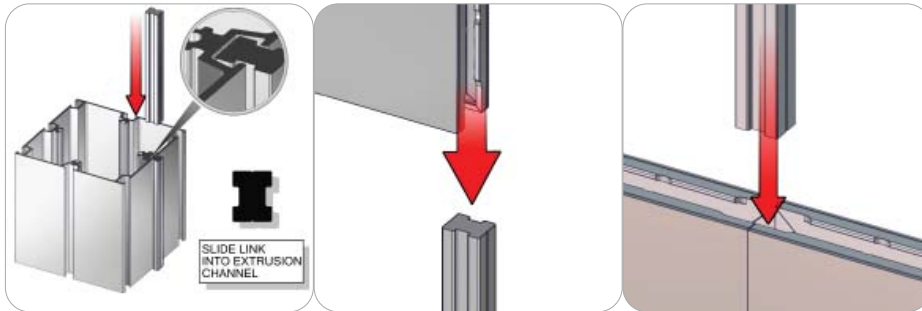

The LN180 extrusion link can be used with most extrusion profiles and laminate panels. Simply slide the LN180 into the channels of the extrusion profile or side of the laminate panels. Some extrusions and laminate panels may have tension glides to hold the LN180 link in place. You should never have to force the LN180 link into any channels. Make sure the LN180 link is straight before you try to install it.

## Connection Method 2: PM4D-600-TG

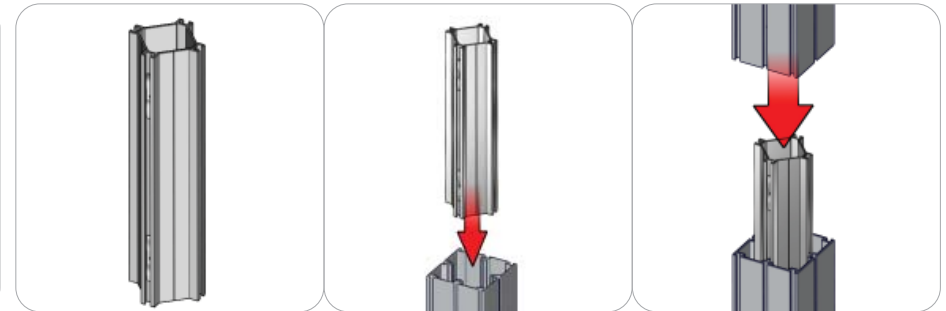

First, take the PM4DSC connector and align it with the internal channels of the next extrusion. Second, slide the connector into the inside channels of the extrusion. The tension glides on the connector will keep it center and snug. The extrusion will have stop pins pre installed to stop it from sinking in. Third, take the next extrusion and apply it on top of the connector completing your connection.

## Connection Method 3: PL-DP-900-2400-SPLIT

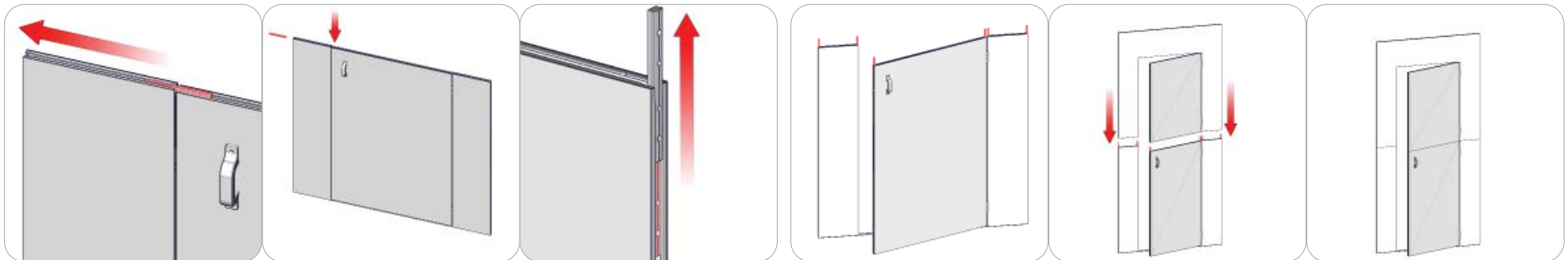

First, take the bottom half of the split door and find the horizontal link bar that keeps the door from opening. Loosen and remove the horizontal link bar to release the door opening. Second, attach the same link bar vertically half way into the top of the bottom door panel. Third, loosen the vertical link bars, slide them up and half way out of the bottom panels. Fourth, there should be 5 vertical link bars half way out of the bottom panels. Make sure they are secured and locked in place. Fifth, take the top half of the split door and align it with the bottom half. Carefully slide the link bars into the top half and tighten them in place.

# Connection Methods

## Connection Method 4: TC-30

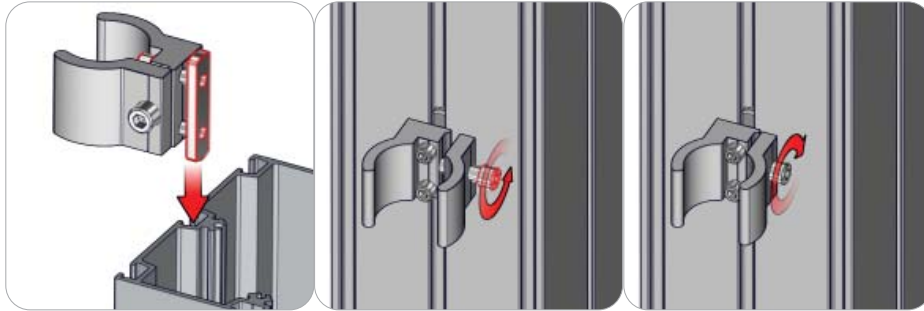

First, loosen the channel bar with the two set screws on the inside of the tube clamp. Do not disassemble it. Slide the clamp channel bar into the desired extrusion channel. Once it is in the desired location, tighten the channel bar screws. Second, loosen the clamp with the side set screw. Do not disassemble it.

## Connection Method 5: FC

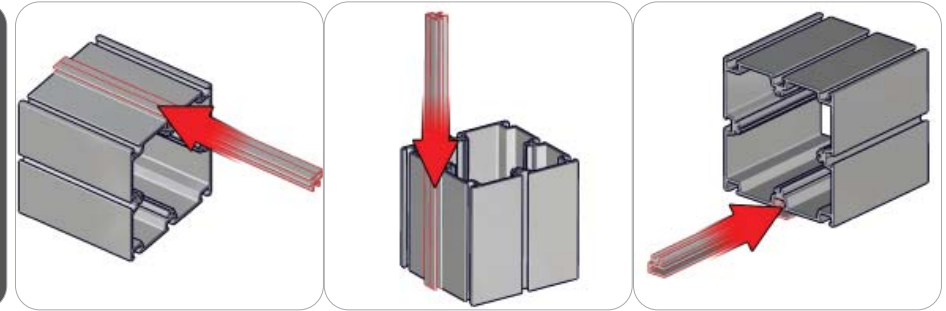

Take the Fabric Channel extrusion (FC) and align it with the desired channel of the next extrusion. Simply slide the FC extrusion into the channels of the extrusion. When making a frame with FC, make sure the channels are all facing in the same direction and are aligned from channel to channel.

## Connection Method 6: PM4S2-L

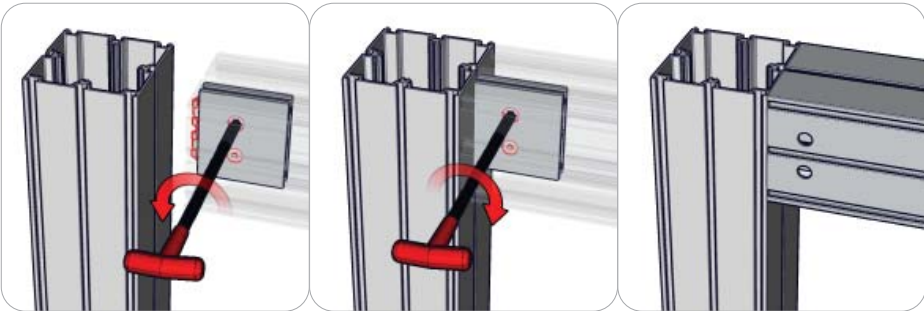

First, with the cam lock disengaged, place the cam lock teeth into the extrusion channel. Second, use the allen key tool to lock it in place. Make half turns clock-wise to engage the cam lock. Do not over tighten the lock buttons.

## Connection Method 7: PM4U-L

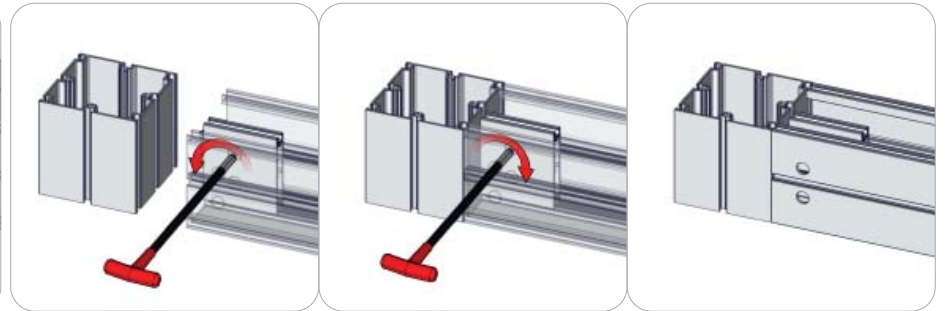

First, with the cam lock disengaged, place the cam lock teeth into the extrusion channel. Second, use the allen key tool to lock it in place. Make half turns clock-wise to engage the cam lock. Do not over tighten the lock buttons.

# Connection Methods

**Connection Method 8: ES30 / ES50 / SNAP BUTTONS**

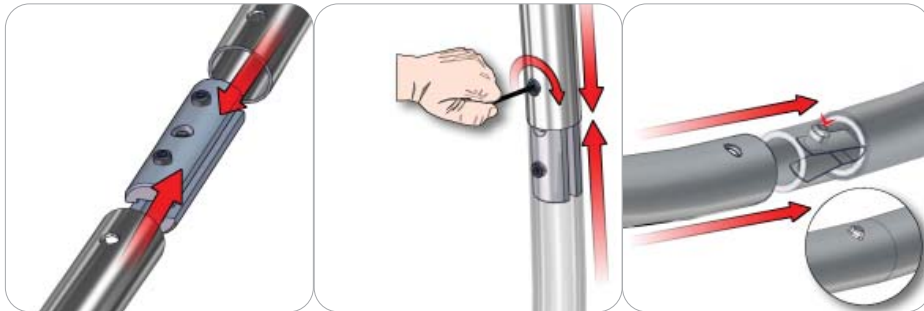

For spigot connections, compress the unlocked connector and slide into the tube lock access hole. Lock both screws carefully using your allen key tool. Be sure to lock securely, but do not over tighten. For snap button connections, locate the snap button on the connector or swage tube. Locate the hole on the corresponding tube. Press the snap button with your thumb and slide the tube and connector together so that the snap button snaps fully into the lock hole. To disassemble, press the snap button and pull apart.

**Connection Method 9: FC Channel Graphic Application**

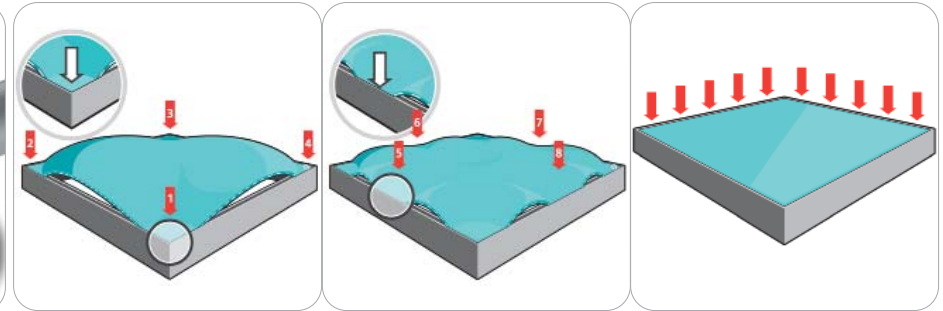

First, insert the silicone edge frame corners into the frame graphic channel (points 1 through 4). Second, insert the silicone edge frame sides into the frame graphic channel (points 5 through 8). Third, push the remaining silicone edge fabric into the frame graphic channel. Similar setup is recommended for the opaque liner. To remove these panels, simply pull the loop tag sewn near a corner.

**Connection Method 10: SS1-1**

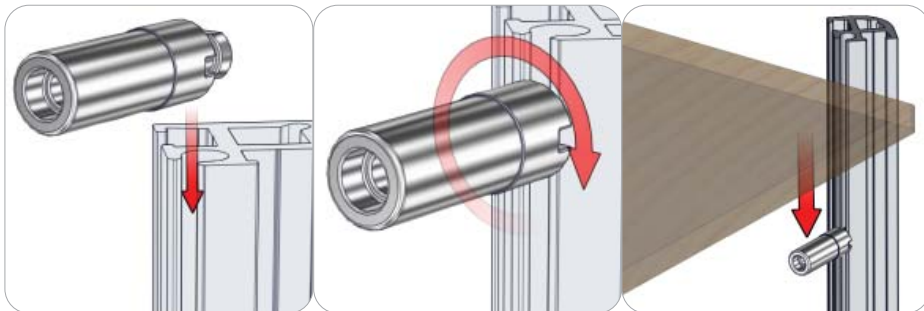

First, take the shelf support and loosen the set screw to about a 1/4 inch gap. Do not remove it. Second, slide the shelf support into the 3mm center channel. Turn the shelf support clock wise to lock it in place. Third, rest the shelf onto the shelf support. Loosen the shelf support to adjust and level.

**Connection Method 11: Link Profiles**

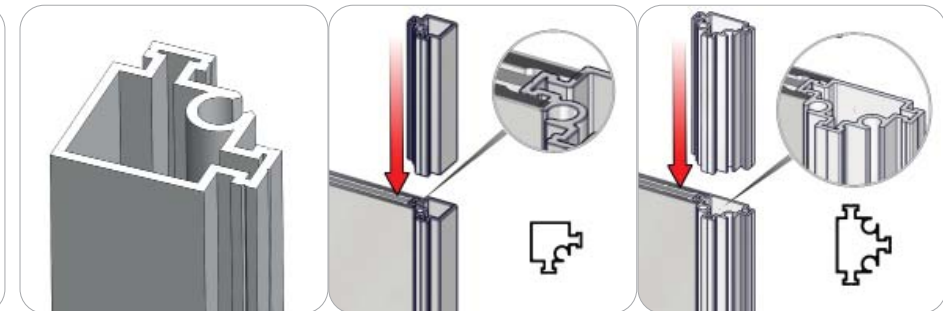

Take the link profile extrusion and slide it into the channel of the next component. There maybe tension glides in that channel, they will help hold the link in place. Make sure the link profile connection is flush at both ends.

# Connection Methods

Connection Method 12: PLT-BP-PM4

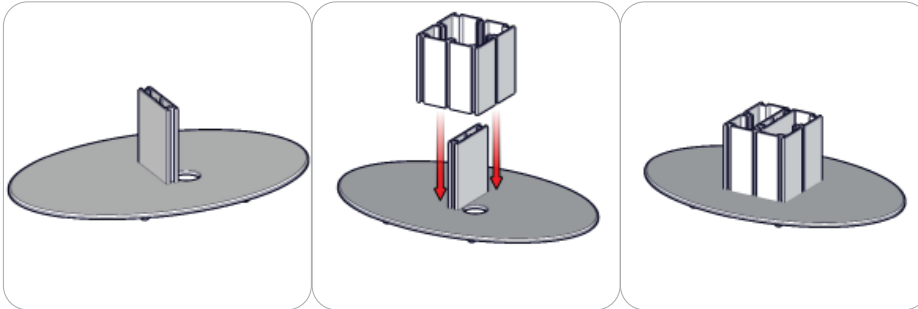

Slide the extrusion post onto the PH2 upright of the base plate. There maybe tension glides in that channel, they will help hold the post in place. Also, the base plate may have a hole for wire management.

Connection Method 13: CKAPS

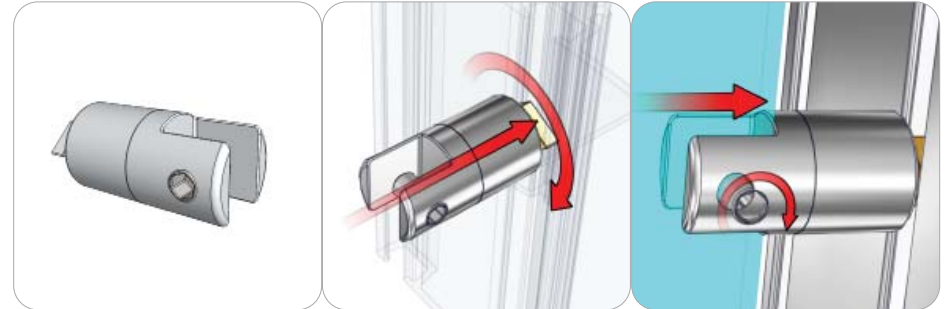

First, screw the CKAPS, clockwise, into the channel until it is tight. Loosen the head screw and make sure the slit in the head is running the correct direction, then tighten back into place. Second, loosen the hex bolt screw and insert the SINTRA and tighten into place. Do not over tighten.

# Kit Assembly

## Step by Step

### Step 1.

Gather the components to build the tower. Use the Exploded View Section 1.1 for part labels and reference the Suggested Layout page for build location.

Reference Connection Method(s) 1 for more details.

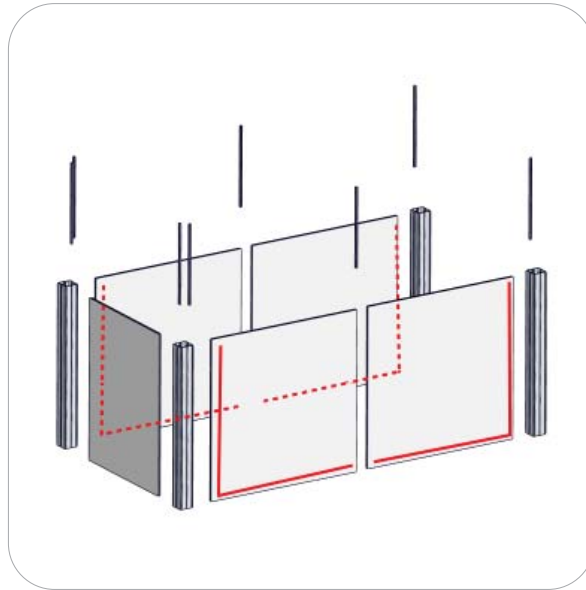
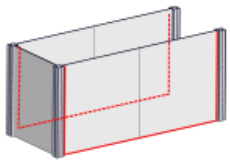

### Step 2.

Gather the components to build the tower. Use the Exploded View Section 1.2 for part labels.

Reference Connection Method(s) 2 and 4 for more details.

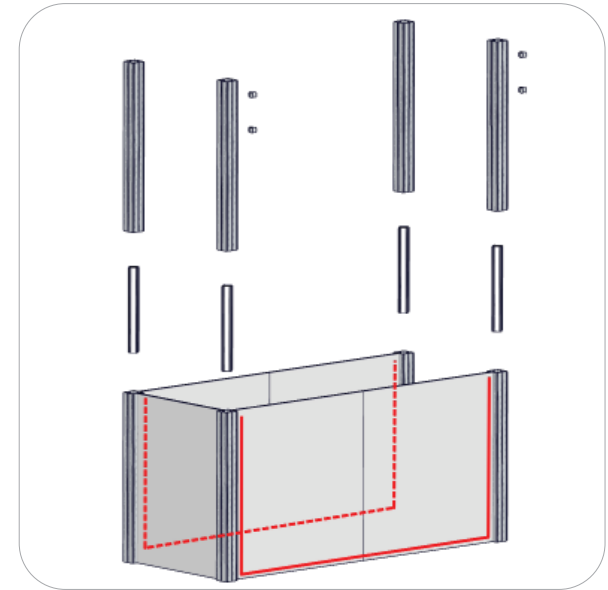
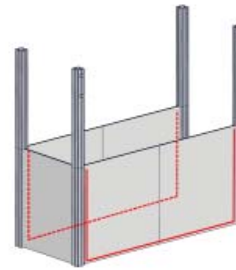

### Step 3.

Gather the components to build the tower door. Use the Exploded View Section 1.3 for part labels.

Reference Connection Method(s) 1 and 3 for more details.

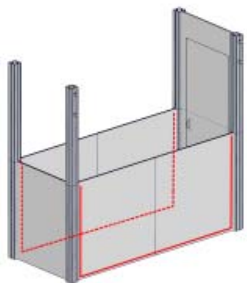

### Step 4.

Gather the components to build the tower. Use the Exploded View Section 1.4 for part labels.

Reference Connection Method(s) 1 for more details.

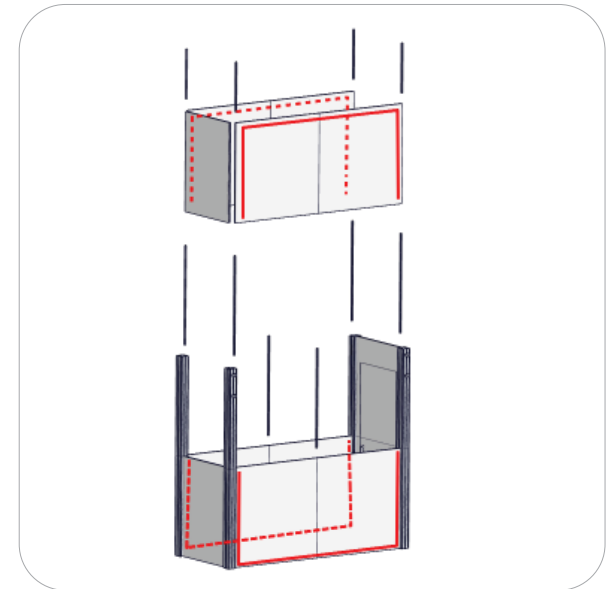
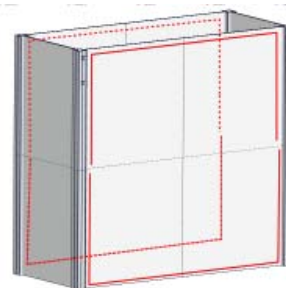



# Kit Assembly

## Step by Step

### Step 5.

Gather the components to build the tower. Use the Exploded View Section 1.5 for part labels.

Reference Connection Method(s) 2 for more details.

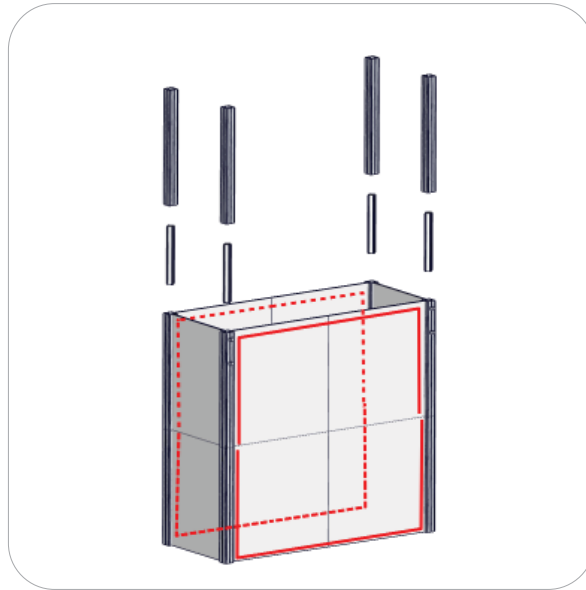
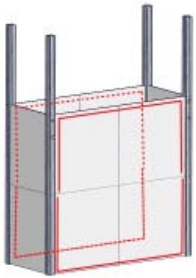

### Step 6.

Gather the components to build the tower. Use the Exploded View Section 1.6 for part labels.

Reference Connection Method(s) 1 for more details.

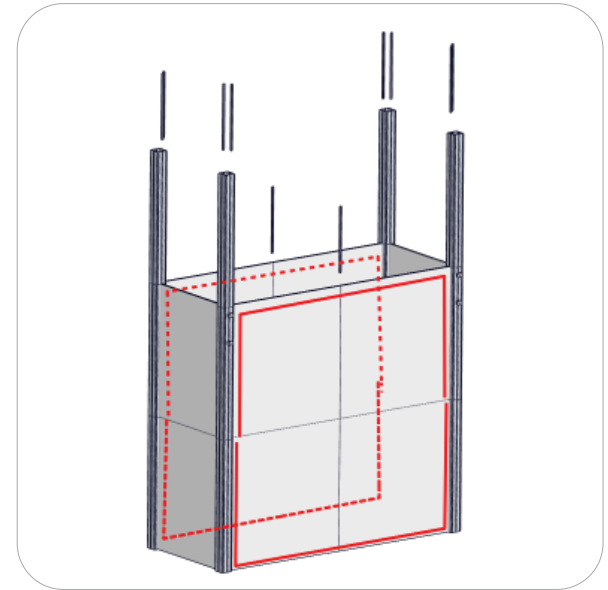
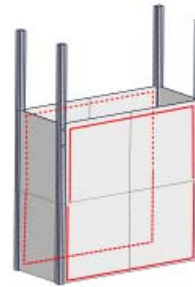

### Step 7.

Gather the components to build the tower. Use the Exploded View Section 1.7 for part labels.

Reference Connection Method(s) 5 and 6 for more details.

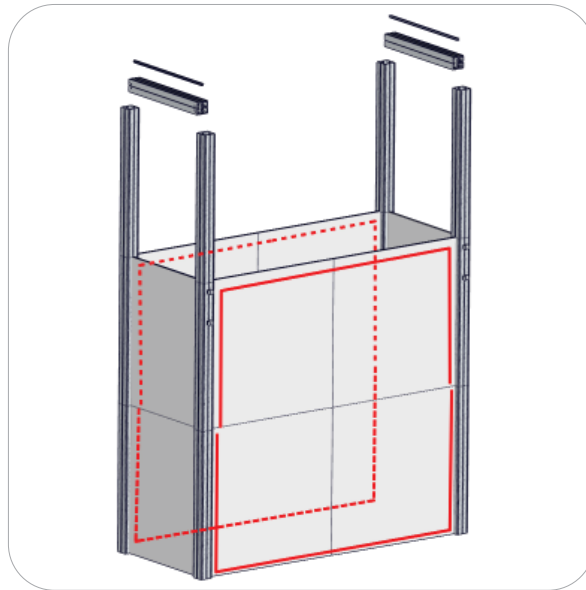
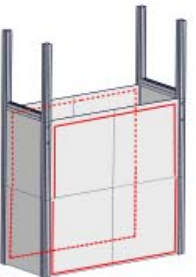

### Step 8.

Gather the components to build the tower. Use the Exploded View Section 1.8 for part labels.

Reference Connection Method(s) 2 and 4 for more details.

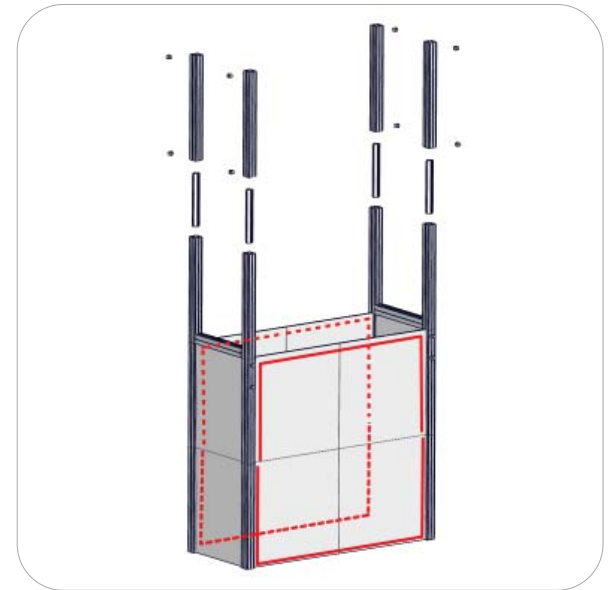
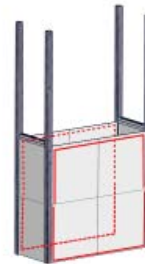



# Kit Assembly

## Step by Step

### Step 9.

Gather the components to build the tower. Use the Exploded View Section 1.9 for part labels.

Reference Connection Method(s) 5 and 7 for more details.

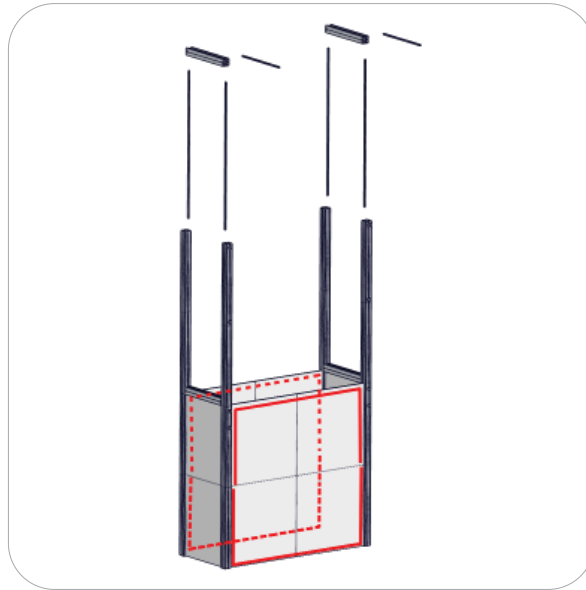
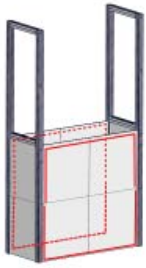

### Step 10.

Gather the components to build the center of the HP-FS-6 frame. Use the Exploded View and the Labeling Diagram 1.10 for part labels. Make 2.

Reference Connection Method 8 for more details.

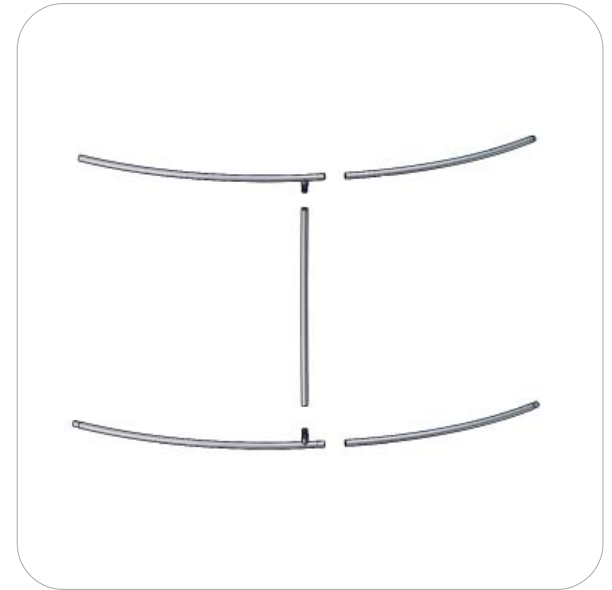

### Step 11.

Gather the components to build the ends of the HP-FS-6 frame. Use the Exploded View and the Labeling Diagram 1.10 for part labels. Make 2.

Reference Connection Method 8 for more details.

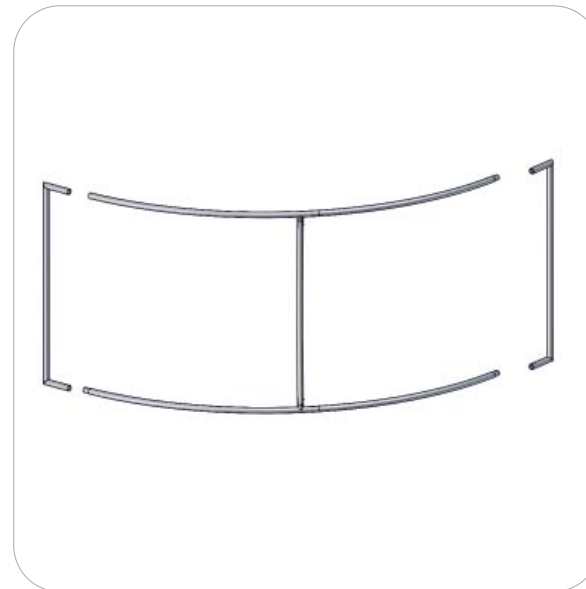

### Step 12.

Apply the pillow case over the HP-FS-6 frame. Zipper it closed at the bottom. Make 2.

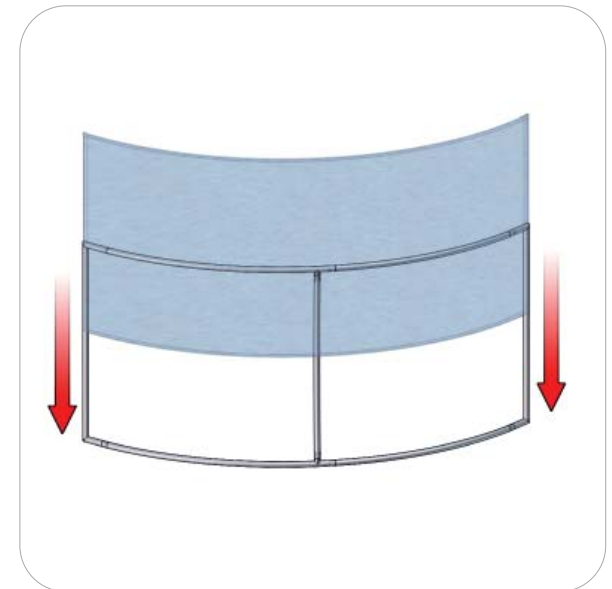

# Kit Assembly

## Step by Step

### Step 13.

Use the tube clamps for attaching the HP-FS-6 headers onto the tower. Use the Exploded View 1.10 for graphic location.

Reference Connection Method(s) 4 for more details.

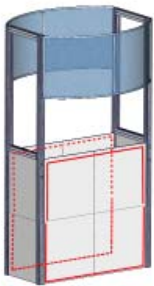

### Step 14.

Attach the spot lights with the provided clamps on the HP-FS-6 headers. Use the Exploded View 1.11 for graphic attachment location. Tower setup complete.

Reference Connection Method(s) 9 for more details.

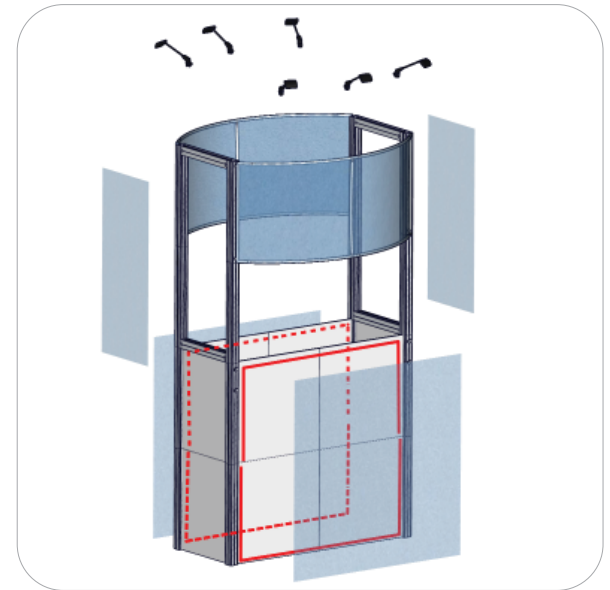

### Step 15.

Gather the components to build the counter cabinet. Use the Exploded View 2.1 for part labels and reference the Suggested Layout page for build location. Make 3.

Reference Connection Method(s) 10 and 11 for more details.

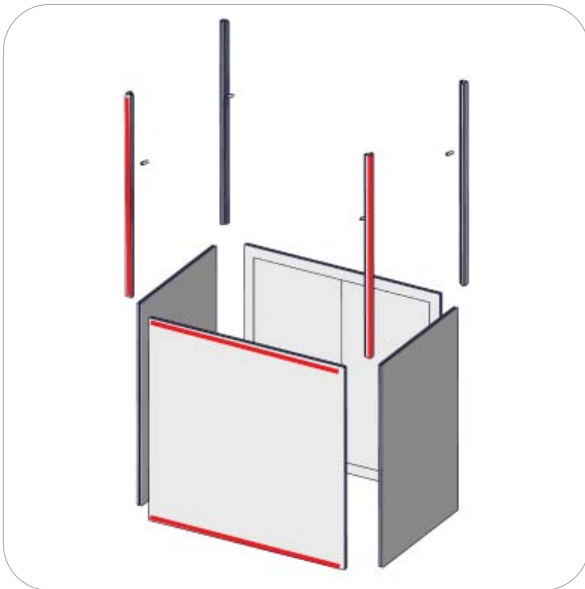
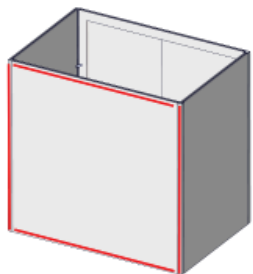

### Step 16.

Gather the components to build the counter internal supports. Use the Exploded View 2.2 for part labels. Make 3.

Reference Connection Method(s) 10 and 12 for more details.

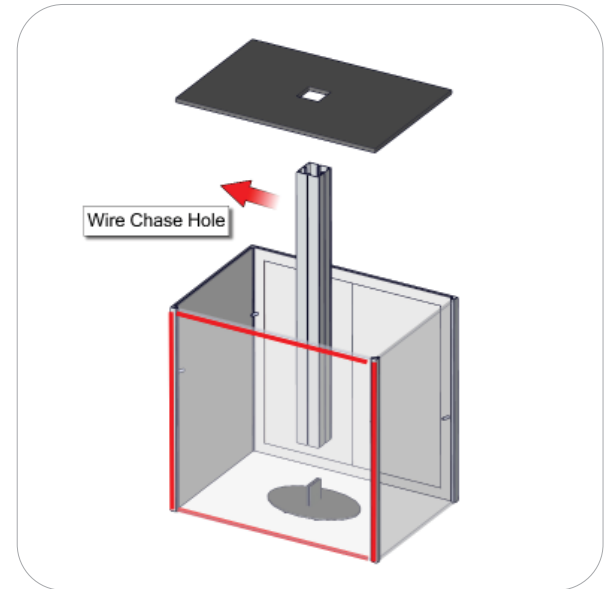
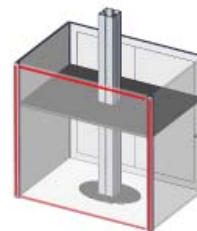

# Kit Assembly

## Step by Step

### Step 17.

Gather the components to build the counter top and post. Use the Exploded View 2.3 for part labels. Make 3.

Reference Connection Method(s) 2 for more details.

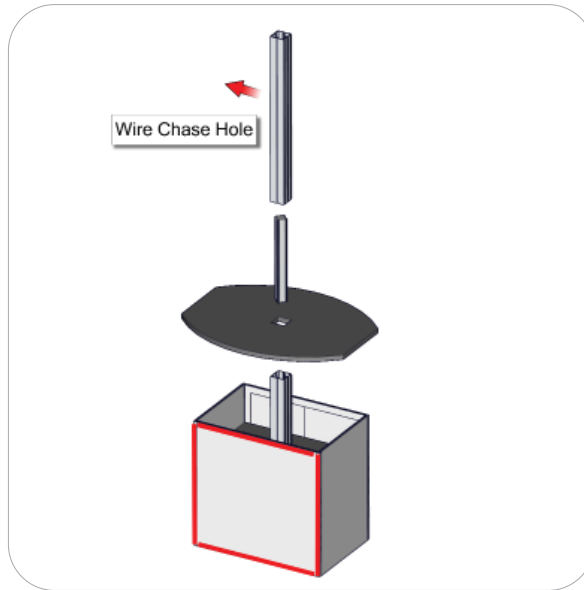
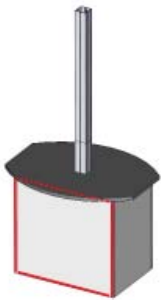

### Step 18.

Attach the monitor mounts, wing clamps and tube clamps. Use the Exploded View 2.4 Counter 1 for part labels.

Reference Connection Method(s) 4, 13 and the monitor mount supplemental sheets for more details.

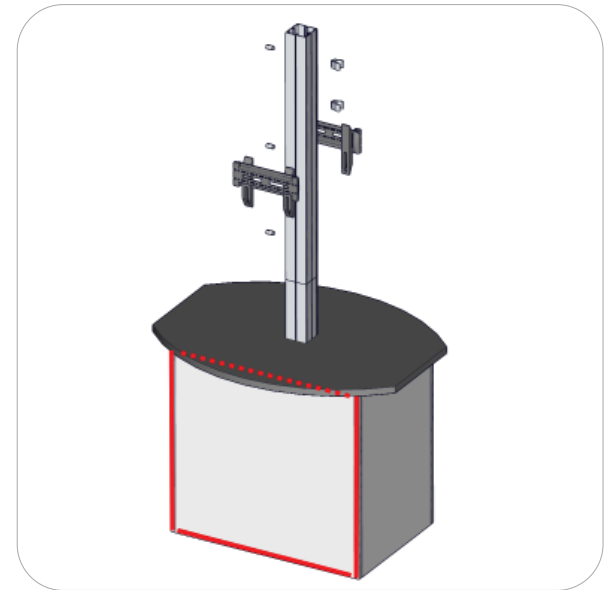
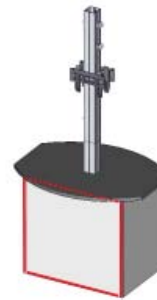

### Step 19.

Attach the monitor mounts, wing clamps and tube clamps. Use the Exploded View 2.5 Counter 2 for part labels.

Reference Connection Method(s) 4, 13 and the monitor mount supplemental sheets for more details.

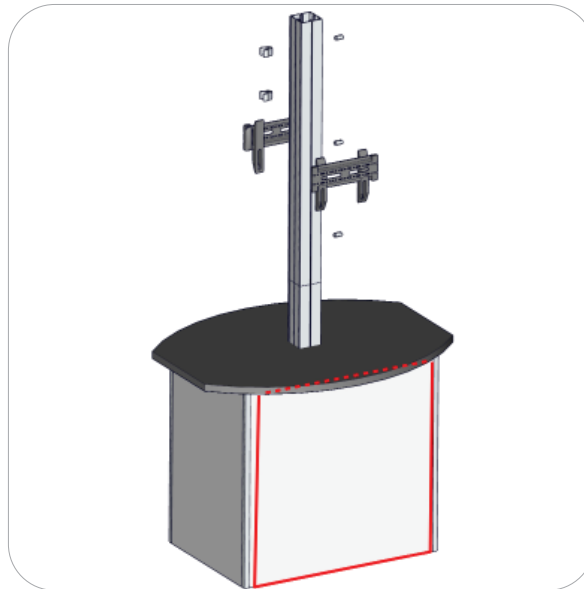

### Step 20.

Attach the monitor mounts and wing clamps. Use the Exploded View 2.6 Counter 3 for part labels.

Reference Connection Method(s) 13 and the monitor mount supplemental sheets for more details.

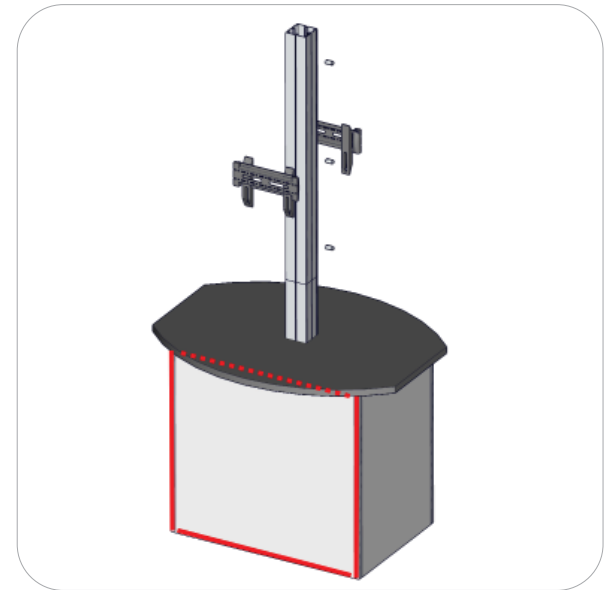
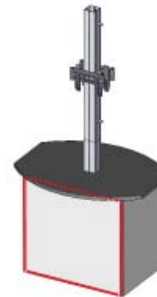

# Kit Assembly

## Step by Step

### Step 21.

Gather the components to build the center of the HP-FS-5 frame. Use the Exploded View and the Labeling Diagram 3.1 for part labels. Make 2.

Reference Connection Method 8 for more details.

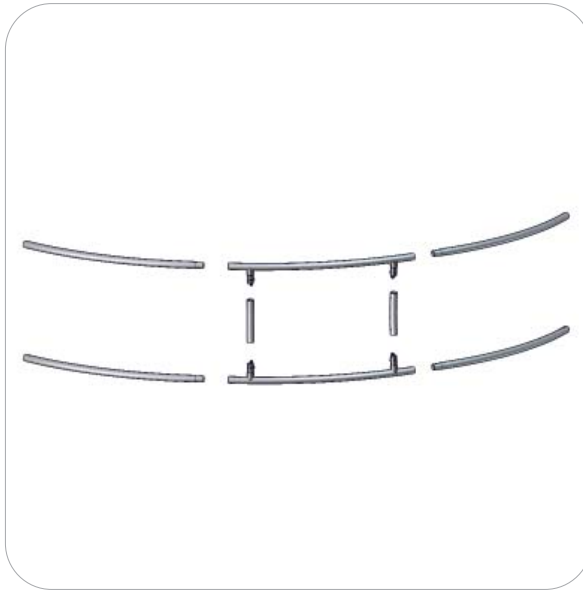

### Step 22.

Gather the components to build the ends of the HP-FS-5 frame. Use the Exploded View and the Labeling Diagram 3.1 for part labels. Make 2.

Reference Connection Method 8 for more details.



### Step 23.

Apply the pillow case over the HP-FS-5 frame. Zipper it closed at the bottom. Make 2.

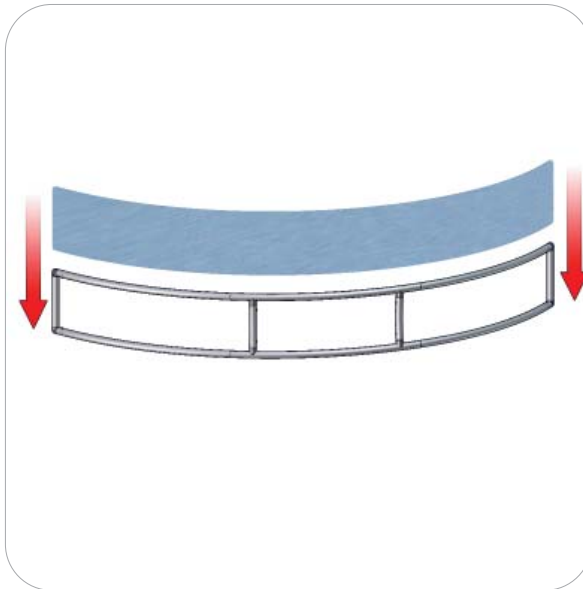

### Step 24.

Use the tube clamps for attaching the HP-FS-5 headers onto the tower and Counters 1 and 2. Use the Exploded View 3.1 for graphic locations.

Reference Connection Method(s) 4 for more details.

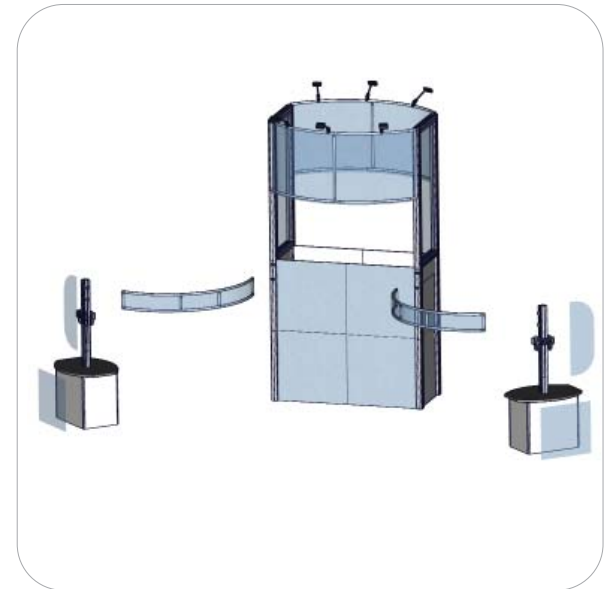

# Kit Assembly

## Step by Step

### Step 25.

Attach the graphic panels onto counter 1. Use the Exploded View 3.1 for graphic labels.

Reference Connection Method 13 for more details.

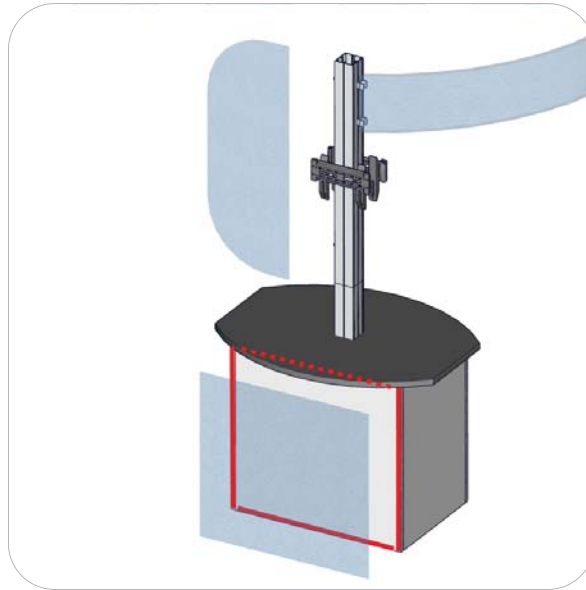
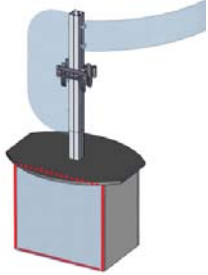

### Step 26.

Attach the graphic panels onto counter 2. Use the Exploded View 3.1 for graphic labels.

Reference Connection Method 13 for more details.

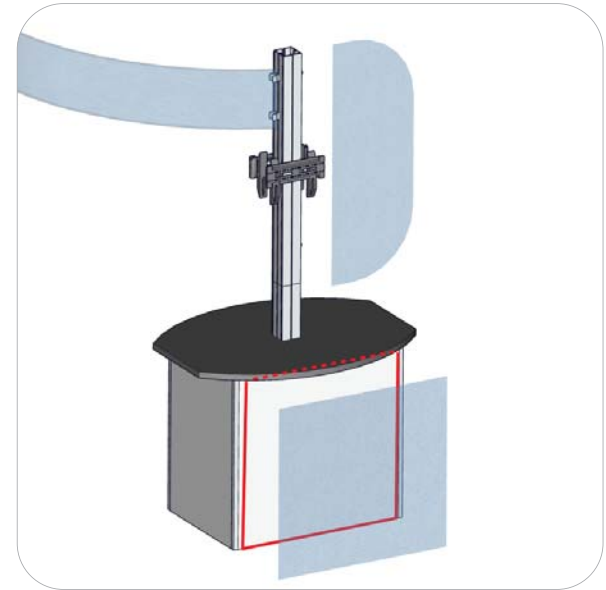
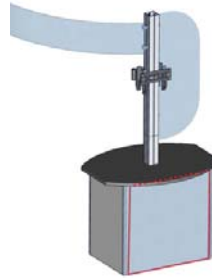

### Step 27.

Attach the graphic panels onto counter 3. Use the Exploded View 2.6 for graphic labels.

Reference Connection Method 13 for more details.

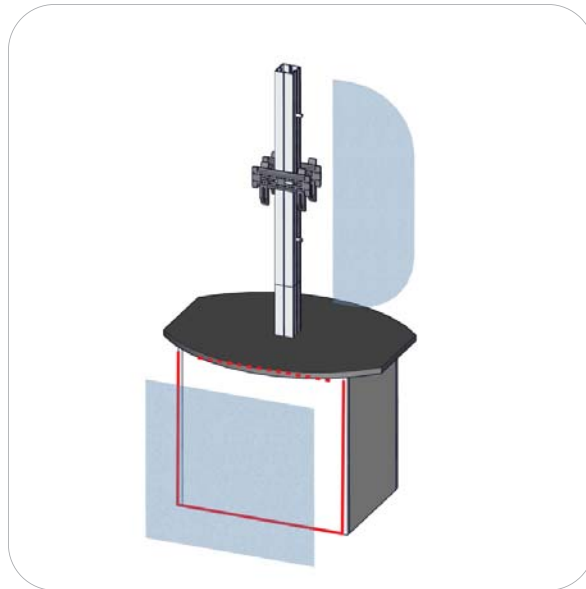
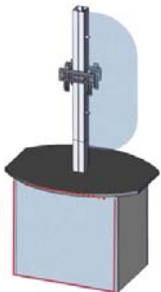

### Step 28.

Connect the power supplies for the spotlights and attach your monitors onto the monitor mounts brackets.

Setup is complete.



# Monitor Bracket Instructions

## Extrusion Channel Applications



### EXT-SM-MB

Sizes: 17" - 37"

Max weight varies per application

**Assembled unit:**

9" w x 16" h x 1.4" d  
230mm (w) x 410mm (h) x 35mm (d)

**Shipping dimensions:**

14" l x 6" h x 4" d  
356mm (l) x 152mm (h) x 102mm (d)

**Approximate total shipping weight:**

6 lbs / 2.7 kgs

**VESA:**

75 x 75 - 200 x 200mm



### EXT-M-MB

Sizes: 32" - 55"

Max weight varies per application

**Assembled unit:**

16" w x 16" h x 1.4" d  
410mm (w) x 410mm (h) x 35mm (d)

**Shipping dimensions:**

24" l x 4" h x 4" d  
610mm (l) x 102mm (h) x 102mm (d)

**Approximate total shipping weight:**

7 lbs / 3.2 kgs

**VESA:**

100 x 100 - 400 x 400mm



### EXT-LG-MB

Sizes: 40" - 65"

Max weight varies per application

**Assembled unit:**

24" w x 16" h x 1.4" d  
610mm (w) x 410mm (h) x 35mm (d)

**Shipping dimensions:**

28" l x 6" h x 6" d  
711mm (l) x 152mm (h) x 152mm (d)

**Approximate total shipping weight:**

8 lbs. / 3.6 kgs

**VESA:**

100 x 100 - 600 x 400mm

### Included hardware:

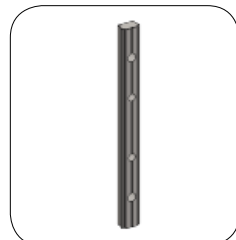

LN-100

x2



M5 x 10

LN-LCD-SCW

x2



1/4"-20 x 1"

BOLT-1

x2

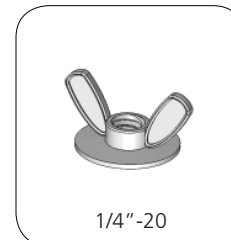

1/4"-20

Flange Wingnut

x2



# EXTRUSION CONNECTION

## Channel Connection A

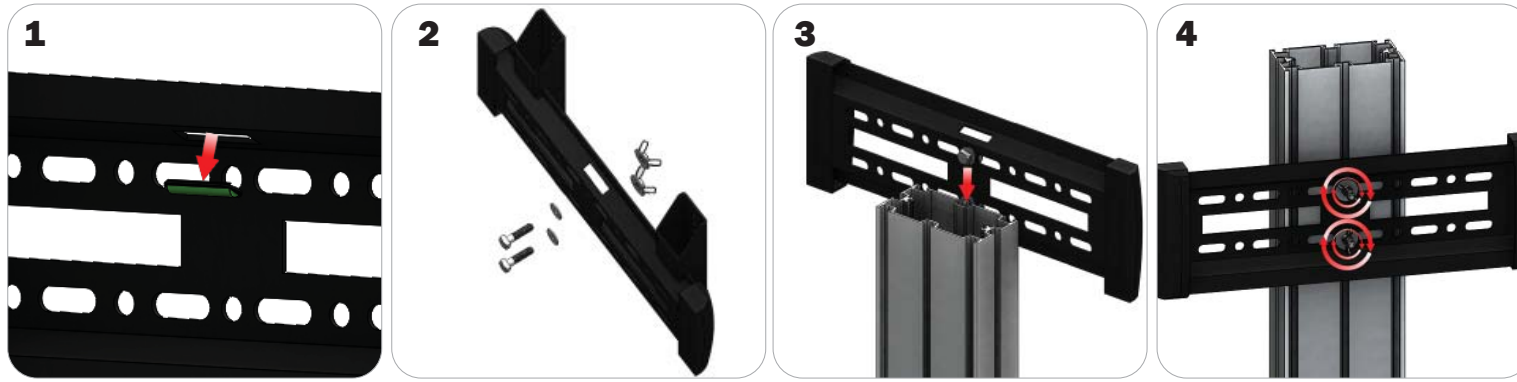

Locate all components needed to assemble the monitor mount with the channel connection A method. You will need (1) monitor bracket, (2) square head bolts, (2) washers, and (2) wingnuts.

**Step 1:** Apply pressure to the rear side of the leveling gauge clipped into the monitor mount to remove it. **Step 2:** Insert the provided bolts through the washers and center top and bottom holes of the monitor mount. Loosely thread your wingnuts onto the end of the bolts. **Step 3:** Slide the bolt heads down the extrusion channel.

**Step 4:** Tighten your wingnuts to lock the monitor bracket in place. **Step 5:** Reference the included manufacturer monitor mount instructions for fastening your monitor to the bracket.

## Channel Connection B

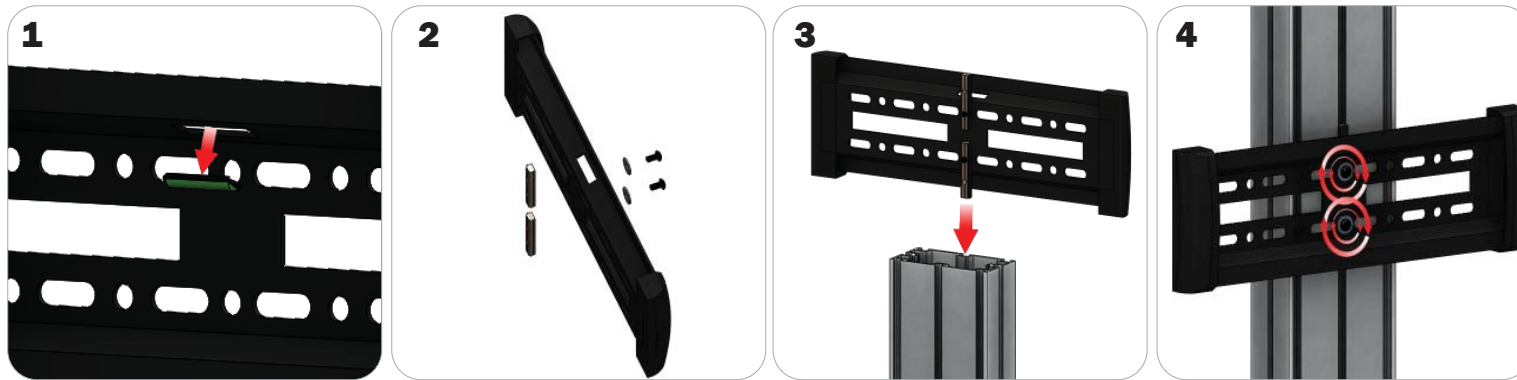

Locate all components needed to assemble the monitor mount with the channel connection B method. You will need (1) monitor bracket, (2) LN-LCD-SCW, (2) LN-100, and (2) washers.

**Step 1:** Apply pressure to the rear side of the leveling gauge clipped into the monitor mount to remove it. **Step 2:** Loosely thread the LN-LCD-SCW screws through the washers, the center top and bottom holes of the monitor bracket, and through the LN-50 holes. **Step 3:** Slide the LN-100s down the extrusion channel. **Step 4:** Tighten your LN-LCD-SCW to lock the monitor bracket in place.

**Step 5:** Reference the included manufacturer monitor mount instructions for fastening your monitor to the bracket.

## TRI-30MM Channel Tube Connection



Locate all components needed to assemble the monitor mount with the TRI-30MM Channel Tube Connection method. You will need (1) monitor bracket, (2) Square Bolts, and (2) Wingnuts.

**Step 1:** Slip the head of the square bolts into the extrusion channel of the tube. **Step 2:** Apply your monitor bracket to the protruding square bolts. **Step 3:** Lock your monitor bracket to the square bolts using the provided wingnuts. **Step 4:** Reference the included manufacturer monitor mount instructions for fastening your monitor to the bracket.