

Hybrid Pro Modular Kit 17 Version B

HP-K-17-B

Hybrid Pro™ Modular exhibits and counters are a perfect solution for the serious exhibitor. Exhibits feature heavy-duty aluminum extrusion frames and push-fit fabric graphics. Count on making an unforgeable impact with Hybrid Pro Modular exhibit kits, counters, and accessories.



features and benefits:

- Silver aluminum extrusion frame
- 15' 9" tall 20' x 20' island display
- Base structure features white laminate panels for the accessible storage closet with lockable door on the narrow side
- Lifetime hardware warranty against manufacturer defects

- Kit includes: accessible lockable storage space, four pillowcase graphics, two fabric graphic velcro panels, three wing shaped Sintra panels, three counters, six small monitor mounts, six spotlights, two molded shipping cases and one wooden shipping crate

dimensions:

Hardware

Assembled unit:
231.52" w x 198.8" h x 231.52" d
5881mm(w) x 5050mm(h) x 5881mm(d)

Approximate weight:
973 lbs / 442 kgs

Shipping

Packing case(s):
1 WOODCRATE-H

Shipping dimensions:
101" l x 53" h x 49" d
2565mm(l) x 1346mm(h) x 1245mm(d)

Approximate total shipping weight:
1353 lbs / 614 kgs

Graphic

Refer to related graphic template for more information.

Visit:
www.exhibitors-handbook.com/graphic-templates

additional information:

Graphic material:
Dye-sublimation printed fabric
UV printed White PVC

Small monitor bracket holds 17-37" LCD,
max weight 40 lbs / 19 kgs each
Monitors not included

Counters Dimensions:
48" w x 94.5" h x 38" d
Holds a max weight 50 lbs / 23 kgs

Center Tower Dimensions:
102.36" w x 189" h x 43.3" d
Storage Closet Area: 96" w x 36" d



Caution
sharp edges
on metal parts

Panel Colors:



grey



black



white

Tabletop Colors:



silver



black



mahogany



natural

3 person assembly recommended:



We are continually improving and modifying our product range and reserve the right to vary the specifications without prior notice. All dimensions and weights quoted are approximate and we accept no responsibility for variance. E&OE. See Graphic Templates for graphic bleed specifications.

Included In Your Kit

Tools, Components, & Connectors

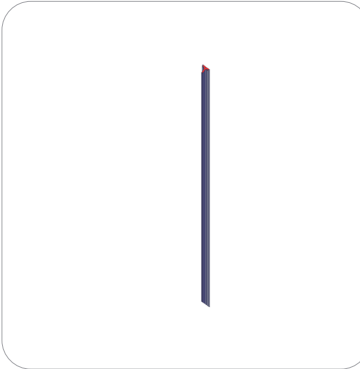

PHFC4-2400-MCB9-MCB9 x4

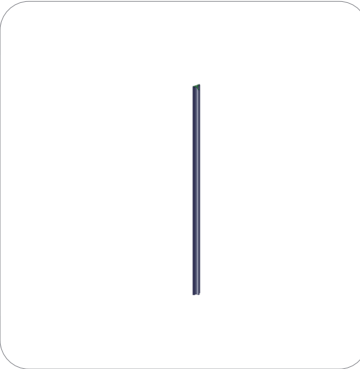

PHFC4-2400-MCB9-MCB9-SIDE x4

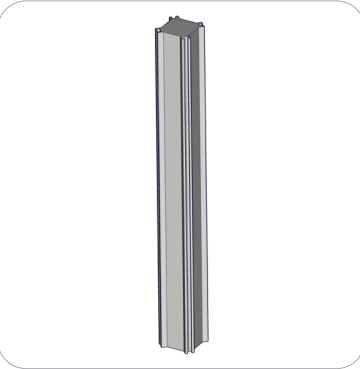

PM4D-600-TG x14

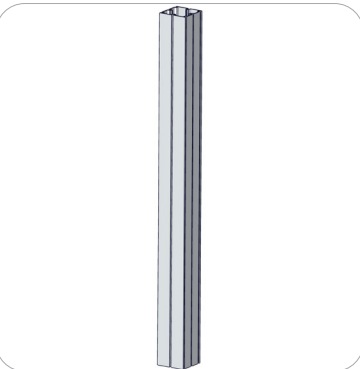

PM4S2-1200-A315-A315 x16

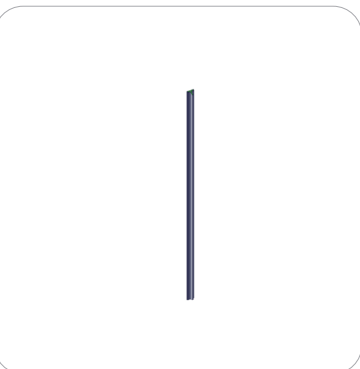

PHFC4-2400-L1-MCB9-SIDE x8



PM4S2-1200-A315-A315-GR x2



PM4S2-1200-A315-A315-GR x2



L90S-900 x8



PHFC4-900-MCB9-MCB9 x3



PH1-2310-L-L x2

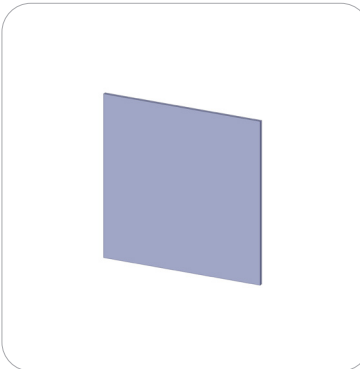

PL-900-900 x2

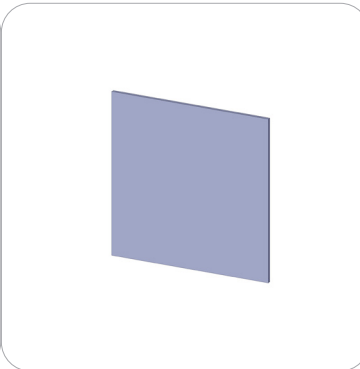

PL-1200-900 x2

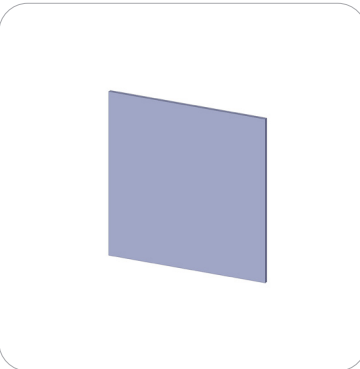

PL-1200-1200 x6

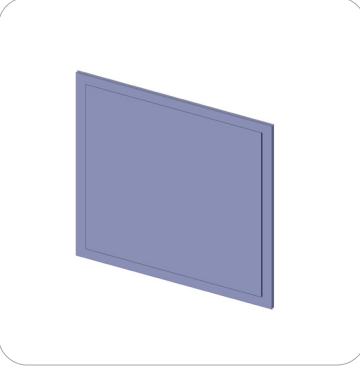

PL-CD-900-900 x2



PL-900-600 x4

Included In Your Kit

Tools, Components, & Connectors



VF-DOOR x1

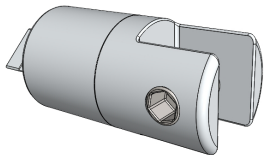

CKAPS x9

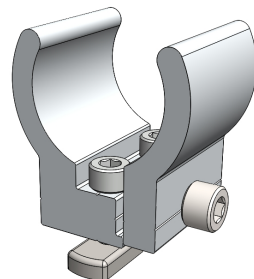

HP-CT-1 x12



EXT-SM-MB x2



HP-CT-1 x2



HP-CT-2 x2

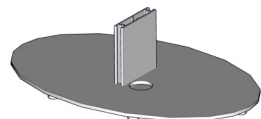

PLT-BP-PM4 x2

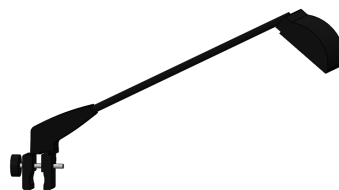

LUM-200-ORL x6



HP-FS-5 x2



HP-FS-6 x2

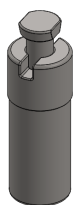

SS1-S x8



HEX KEY SET x1



5MM ALLEN-T x8

Included In Your Kit



HP-FS-5-T1 x4



HP-FS-5-T2 x4



HP-FS-5-T3 x4



HP-FS-5-T4 x4



HP-FS-5-T5 x4

Tubes



HP-FS-6-T1 x4

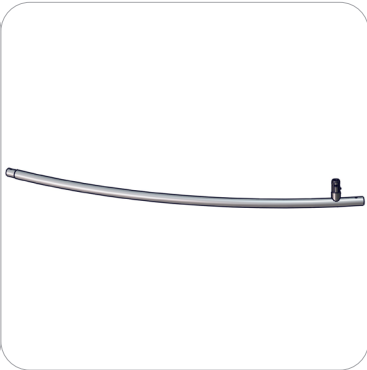

HP-FS-6-T2 x2



HP-FS-6-T3 x2



HP-FS-6-T4 x4



HP-FS-6-T5 x2

Included In Your Kit

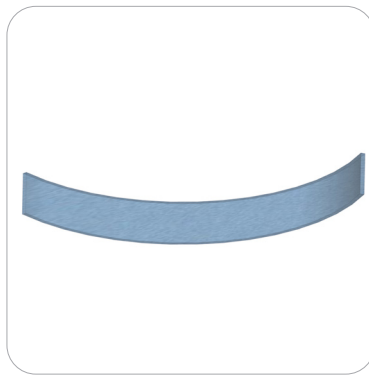

HP-17-A-G x1



HP-17B-B1-G x1

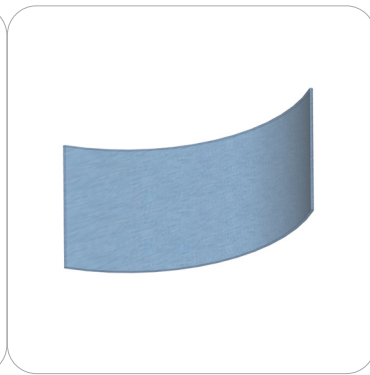

HP-17-C-G x1

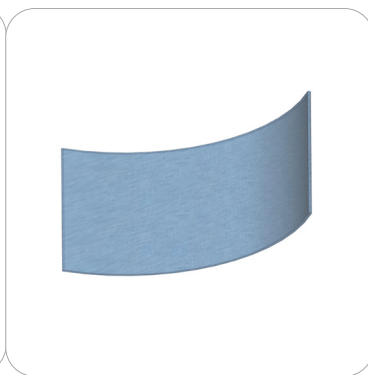

HP-17-D-G x1

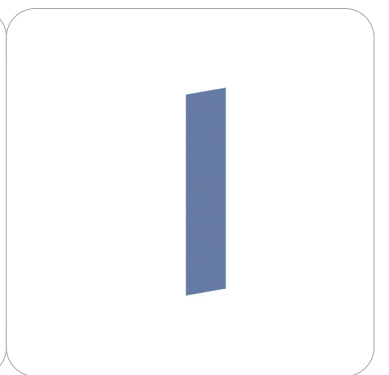

HP-17B-B2-G x1

Graphics

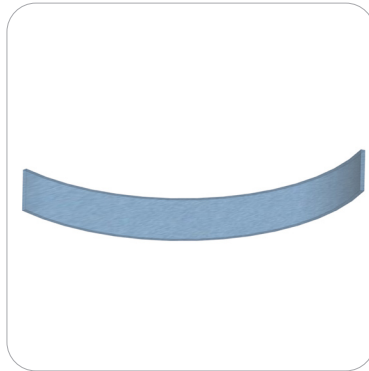

HP-17-F-G x1

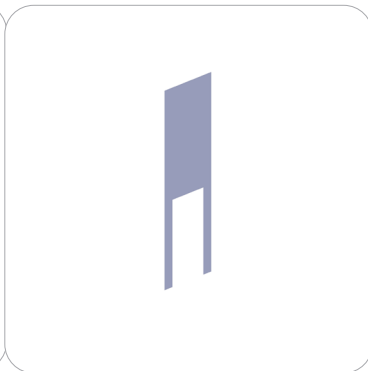

HP-17B-E3-G x1



HP-17-G-G x1



HP-17-I-G x1

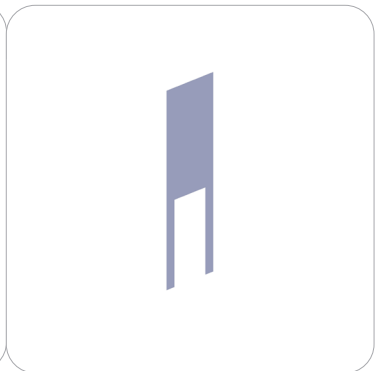

HP-17B-E1-G x1

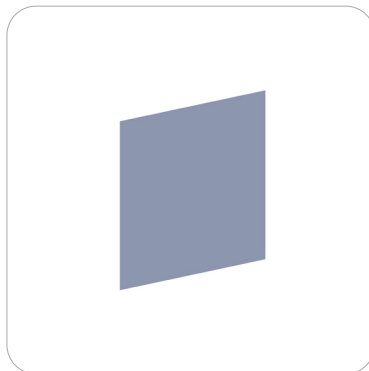

HP-17B-M1-G x1

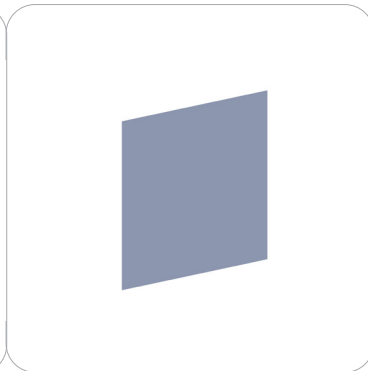

HP-17B-M2-G x1

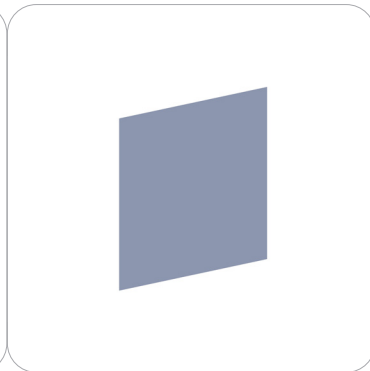

HP-17B-N1-G x1

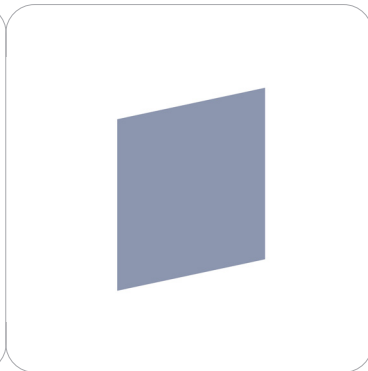

HP-17B-N2-G x1

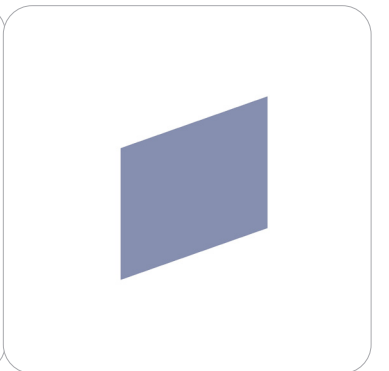

HP-17-J-G x1

Included In Your Kit

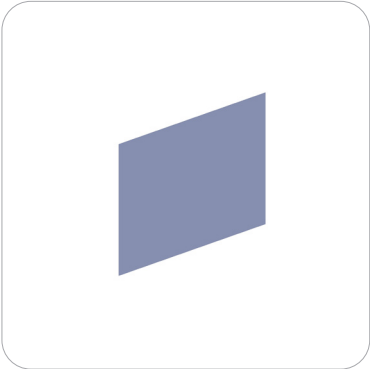

HP-17-L-G x1

Graphics

Exploded View

HP-K-17B

Reference the Suggested Layout page for build location.

-ASSEMBLE 2 VECTOR FRAMES

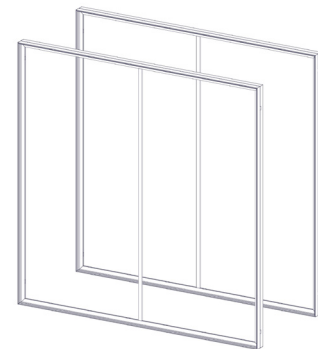
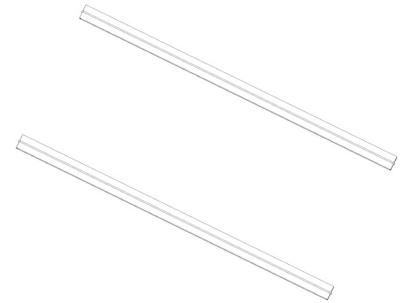
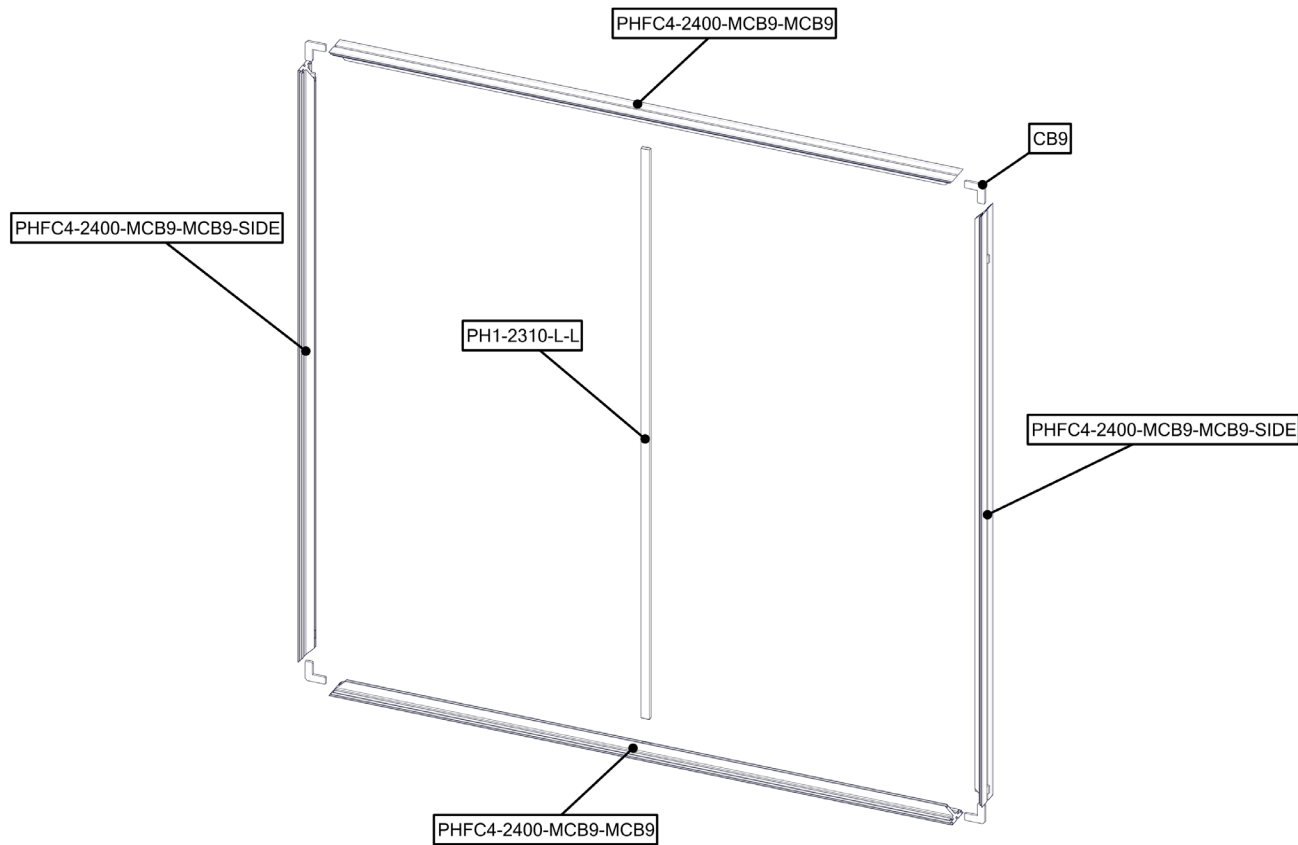

Exploded View

HP-K-17B

Reference the Suggested Layout page for build location.

-ASSEMBLE RIGHT SIDE WALL WITH DOOR

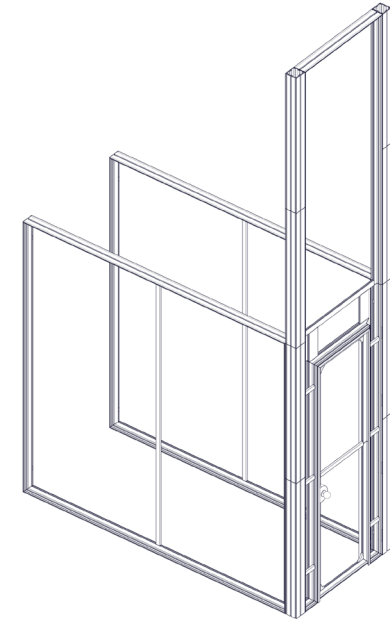
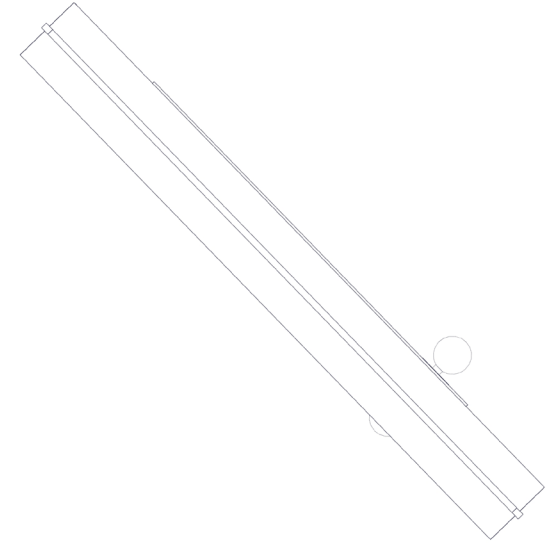
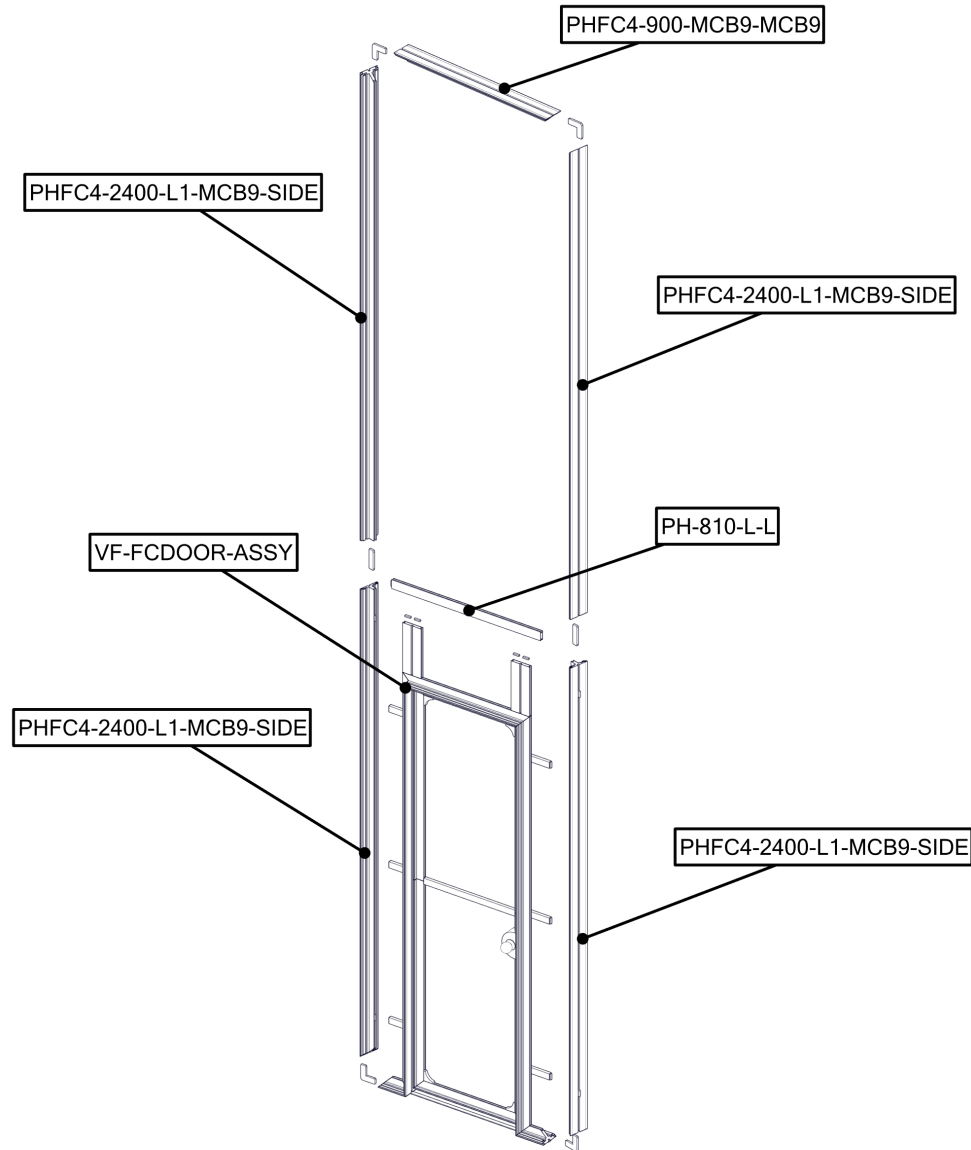

Exploded View

HP-K-17B

Reference the Suggested Layout page for build location.

-ASSEMBLE LEFT SIDE WALL

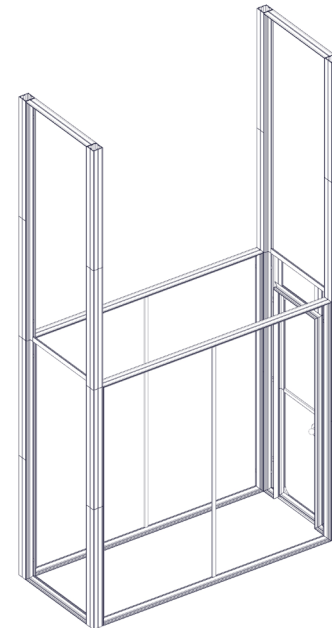
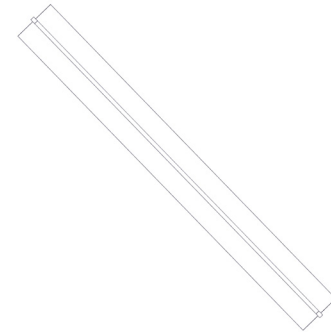
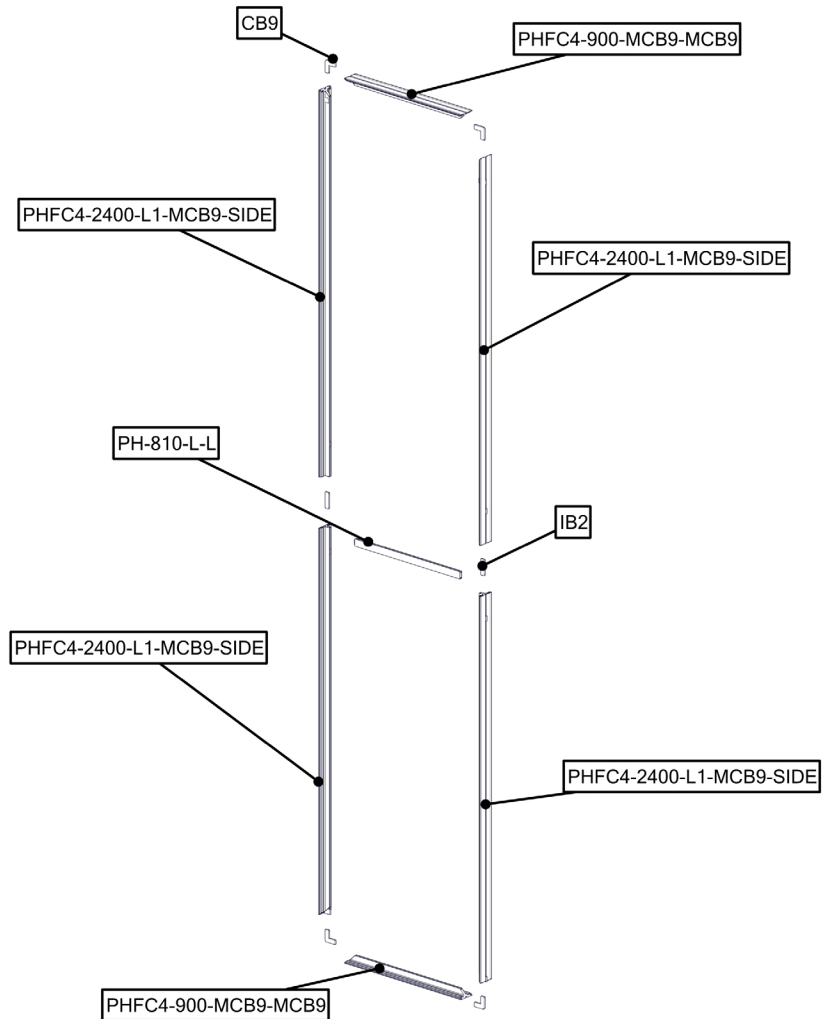

Exploded View

HP-K-17B

Reference the Suggested Layout page for build location.

-ATTACH TC-30 TO FRAME

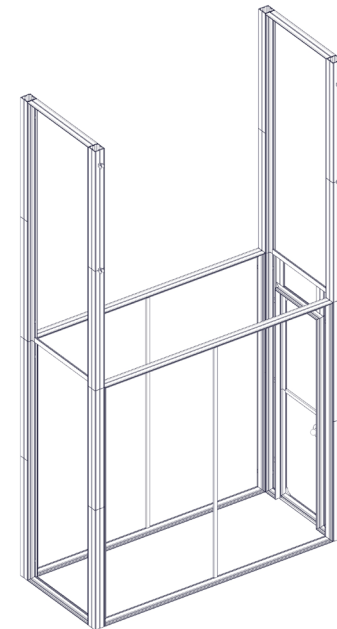
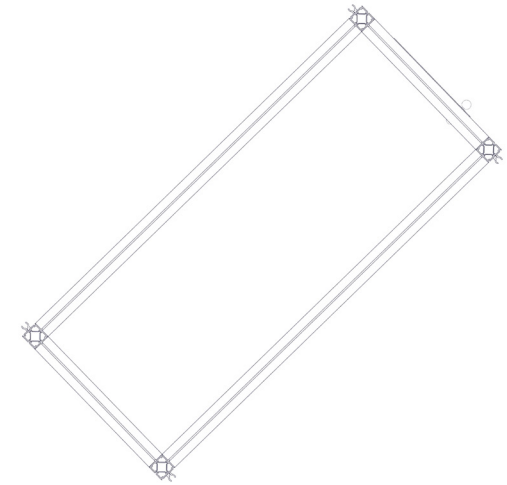
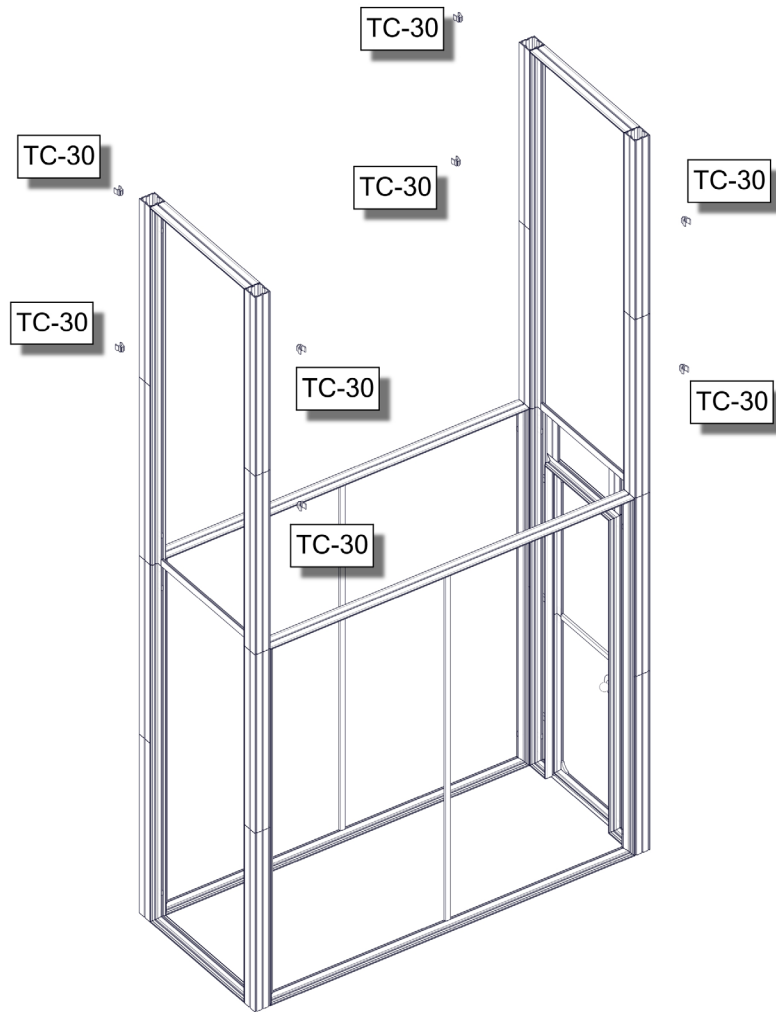

Exploded View

HP-K-17B

HP-FS-6

Reference the Suggested Layout page for build location.

-ASSEMBLE HP-FS-6 TUBES x2

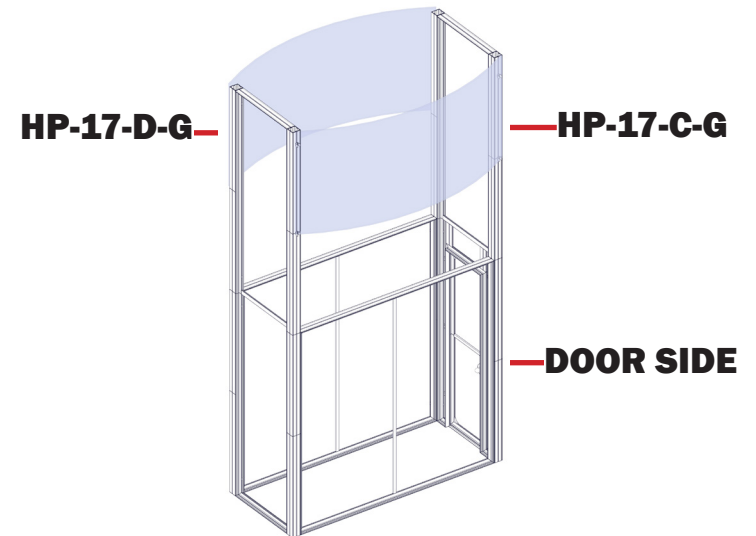
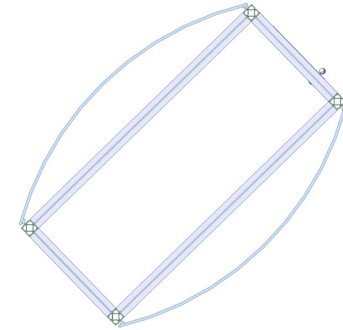
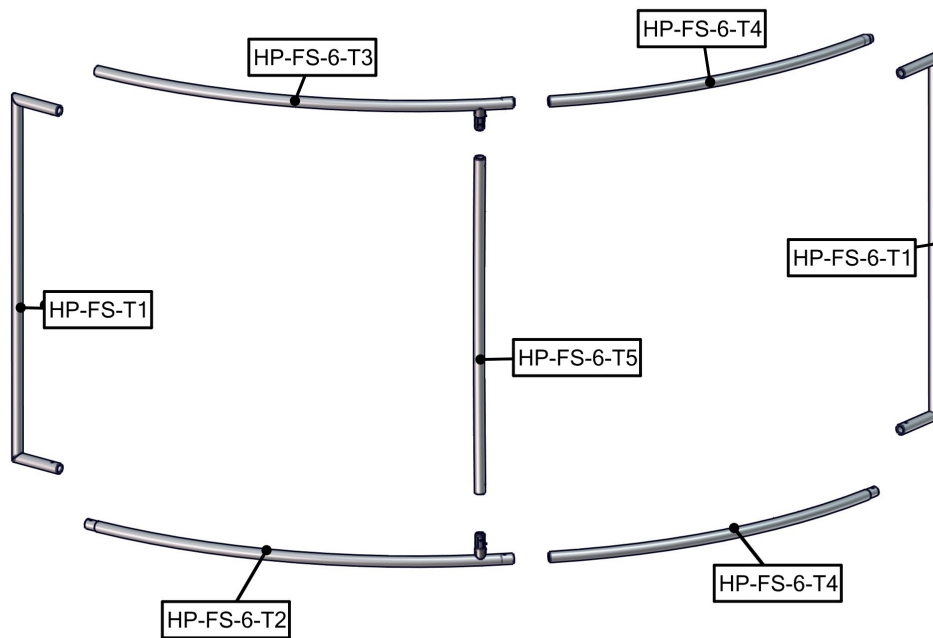

Labeling Diagram

HP-K-17B

Reference the Suggested Layout page for build location.

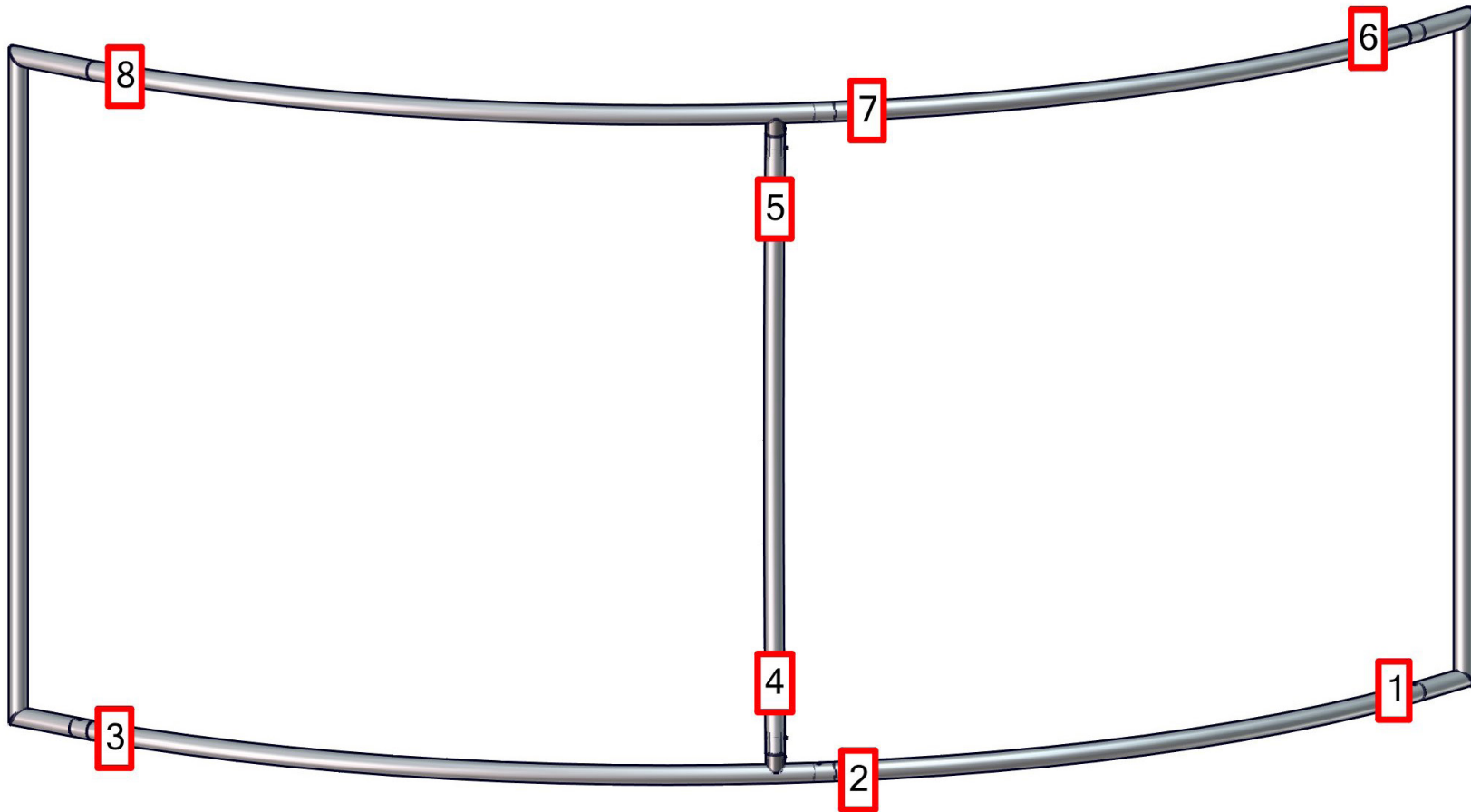

Exploded View

HP-K-17B

Reference the Suggested Layout page for build location.

-ATTACH LIGHTING

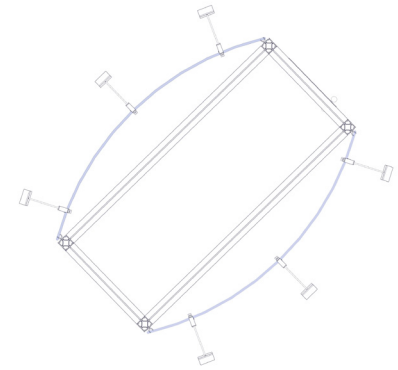
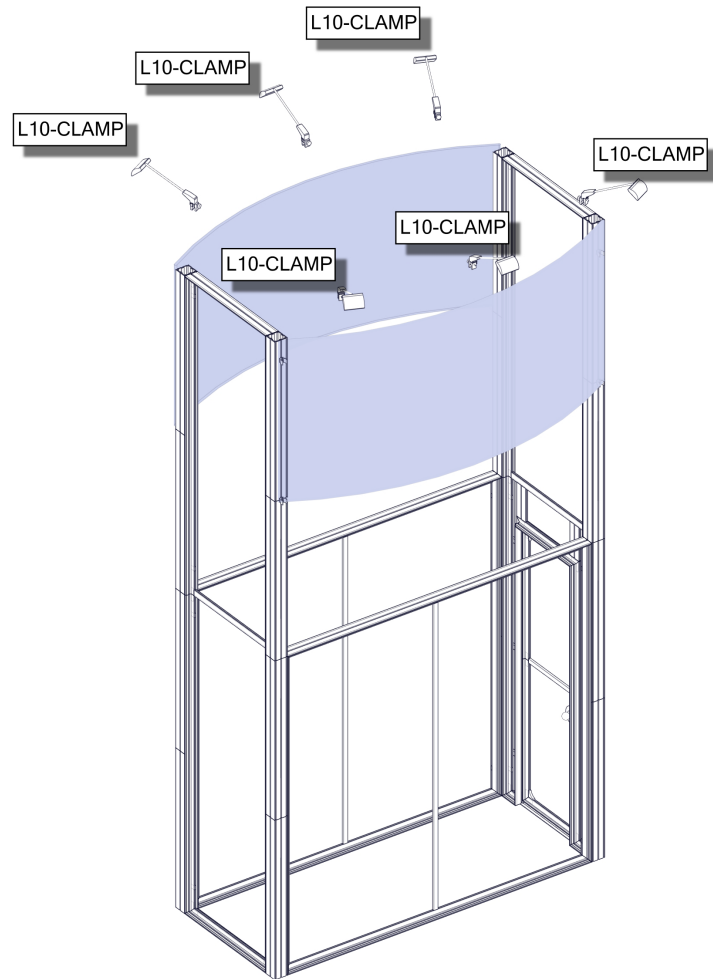

Exploded View

HP-K-17B

Reference the Suggested Layout page for build location.

— **Loop velcro**

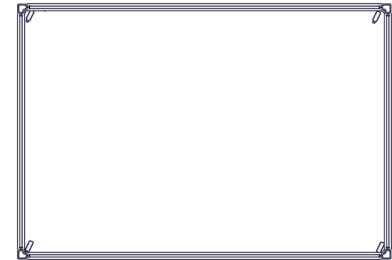
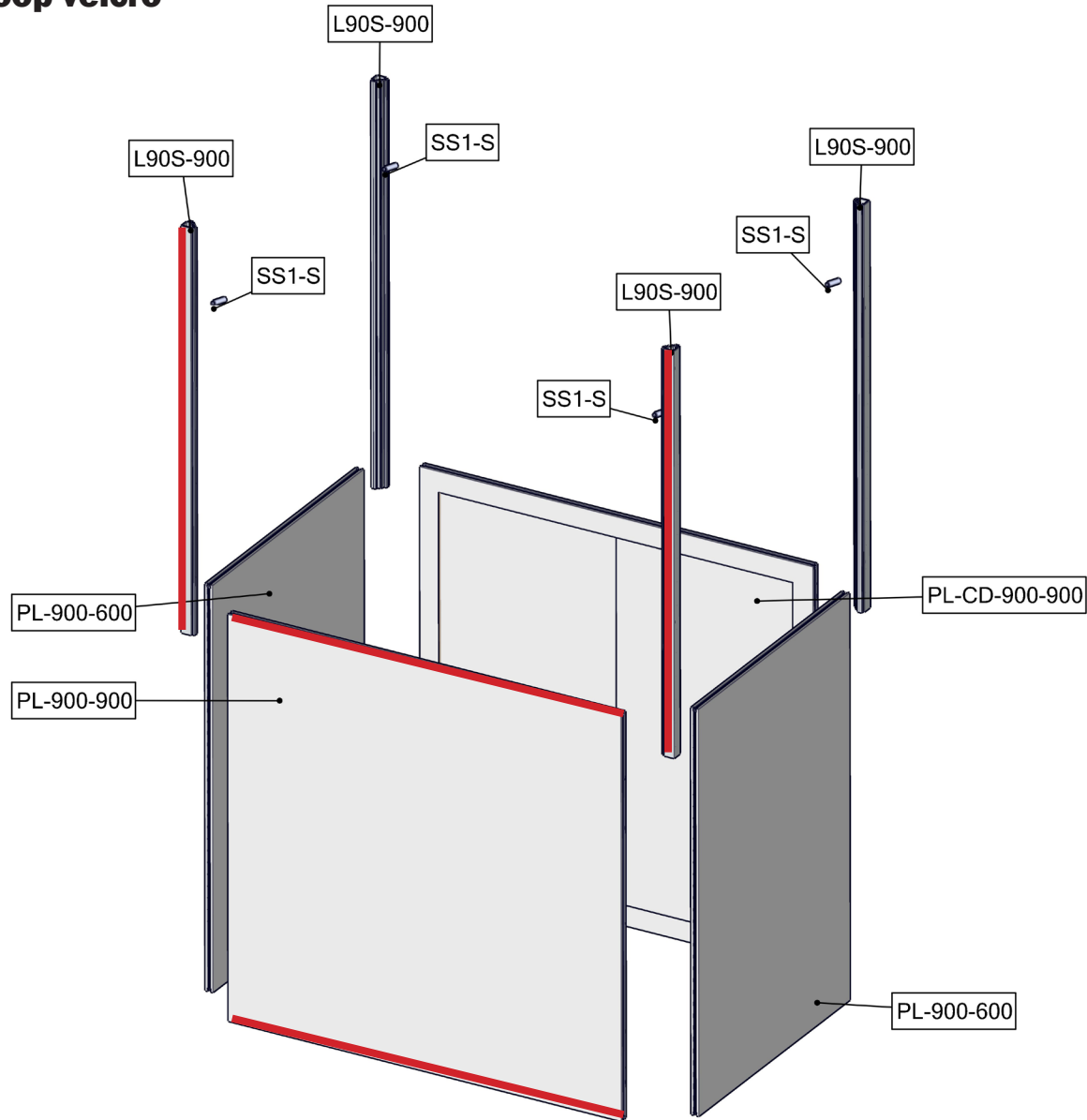

Exploded View

HP-K-17B

Reference the Suggested Layout page for build location.

— **Loop velcro**

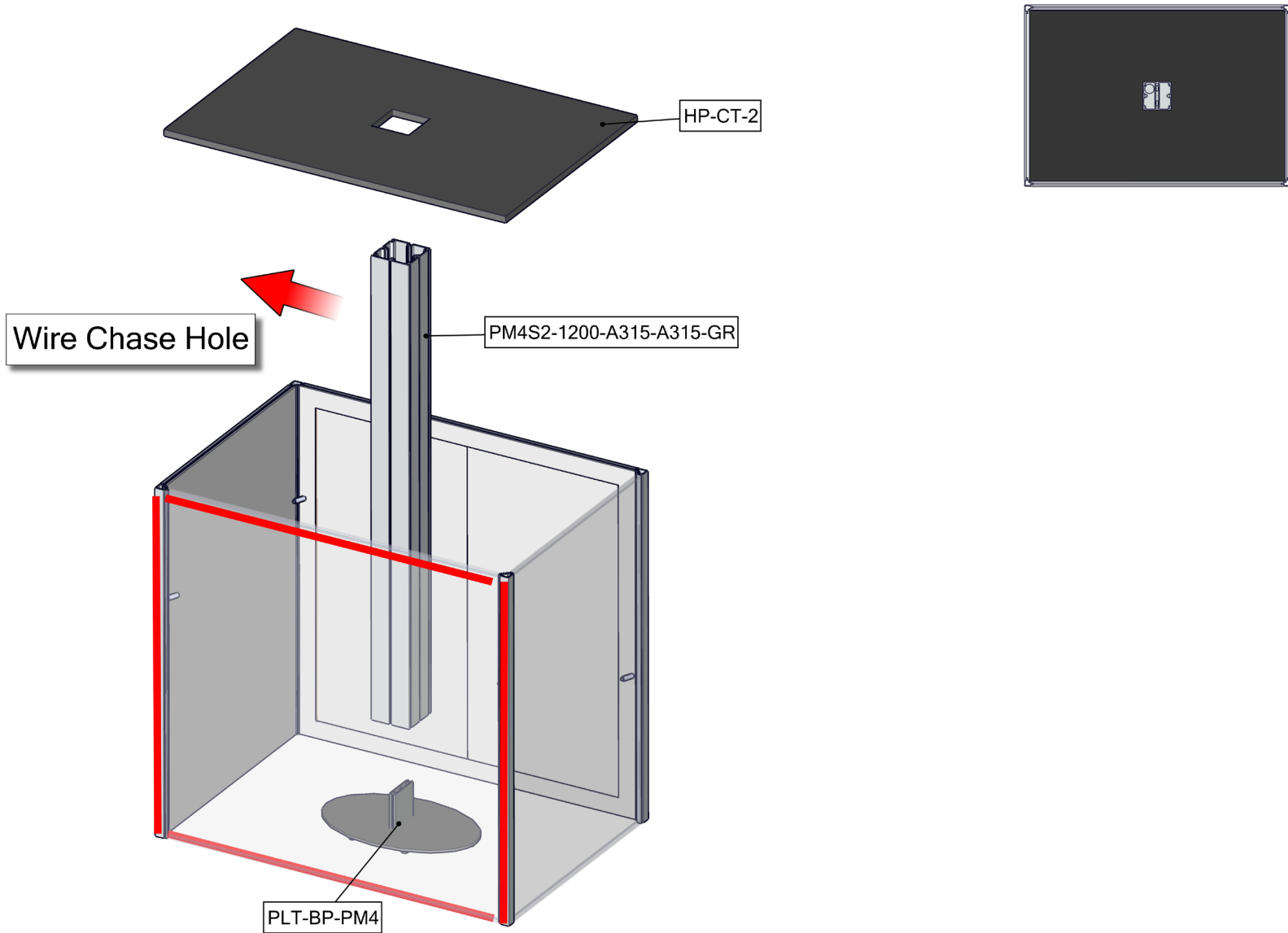

Exploded View

HP-K-17B

Reference the Suggested Layout page for build location.

— **Loop velcro**

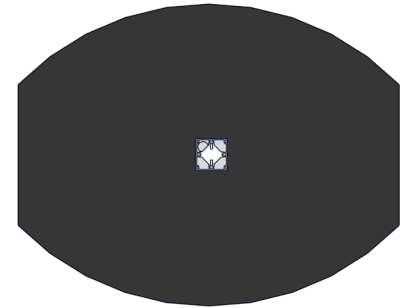
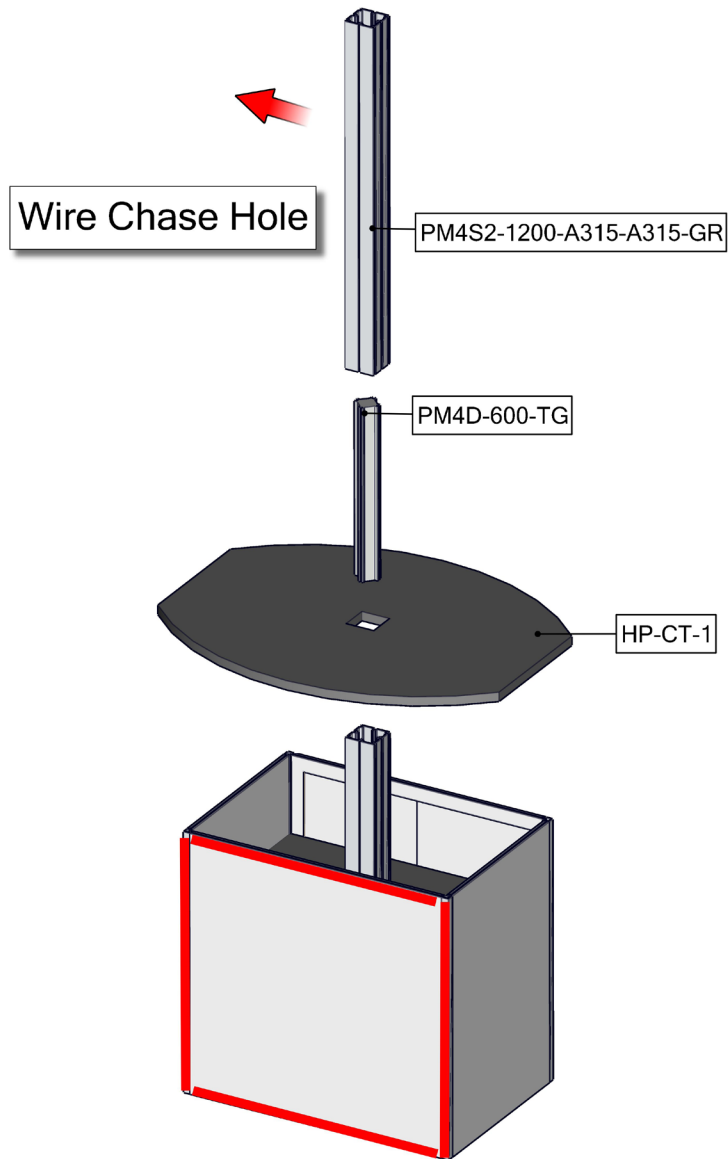

Exploded View

HP-K-17B

Reference the Suggested Layout page for build location.

— **Loop velcro**

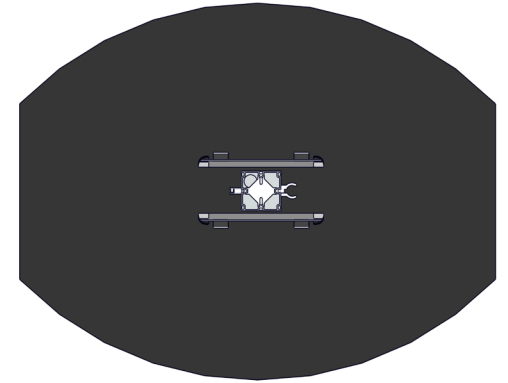
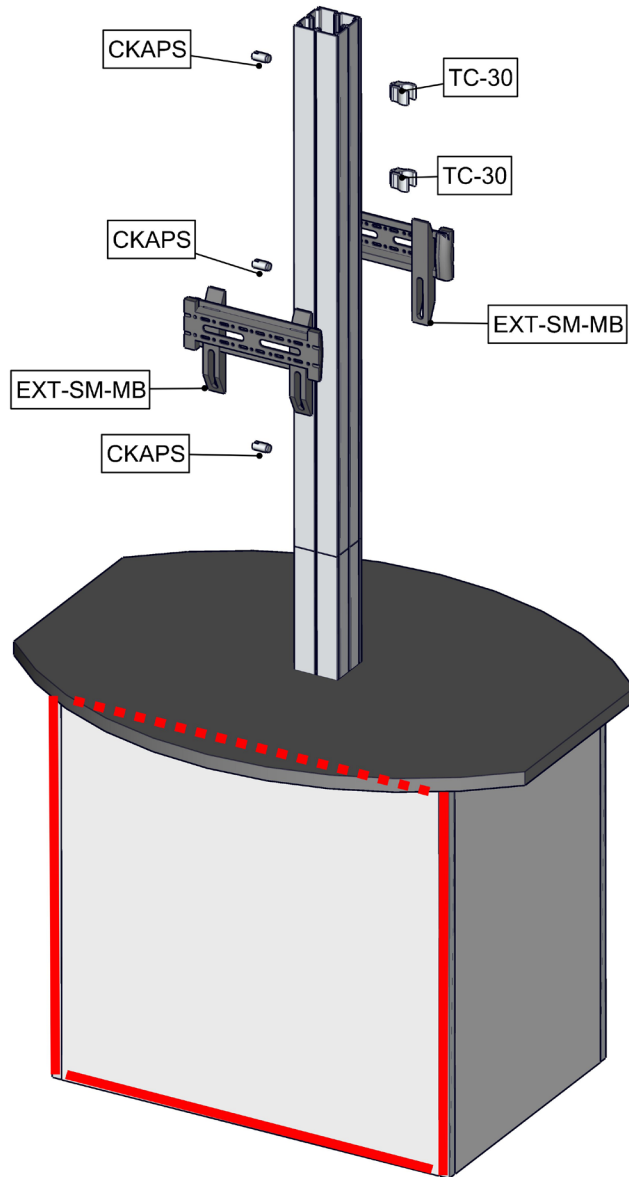

Exploded View

HP-K-17B

Reference the Suggested Layout page for build location.

— **Loop velcro**

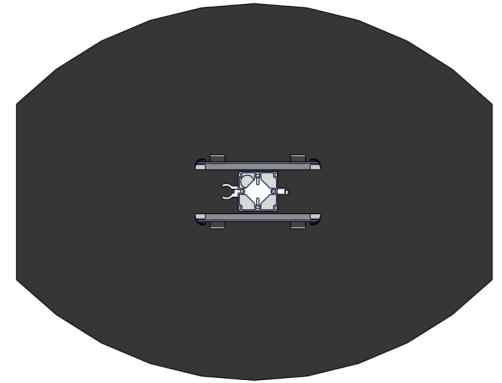
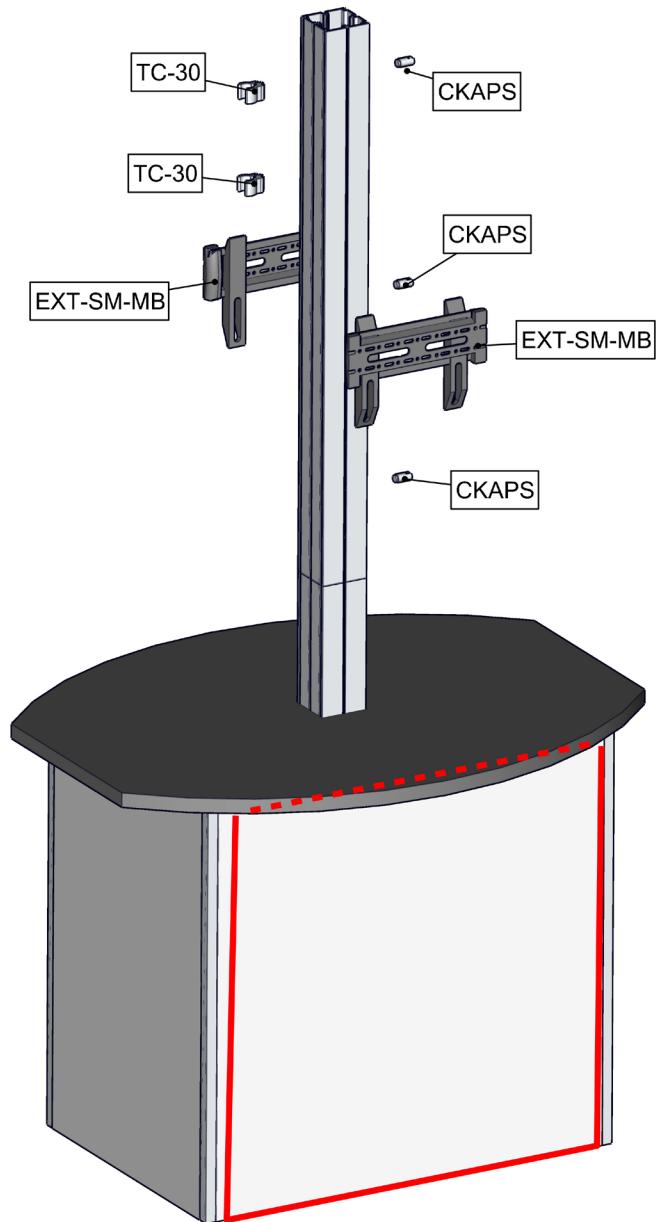

Exploded View

HP-K-17

Section 2.6 Counter 3

Reference the Suggested Layout page for build location.

— Loop velcro

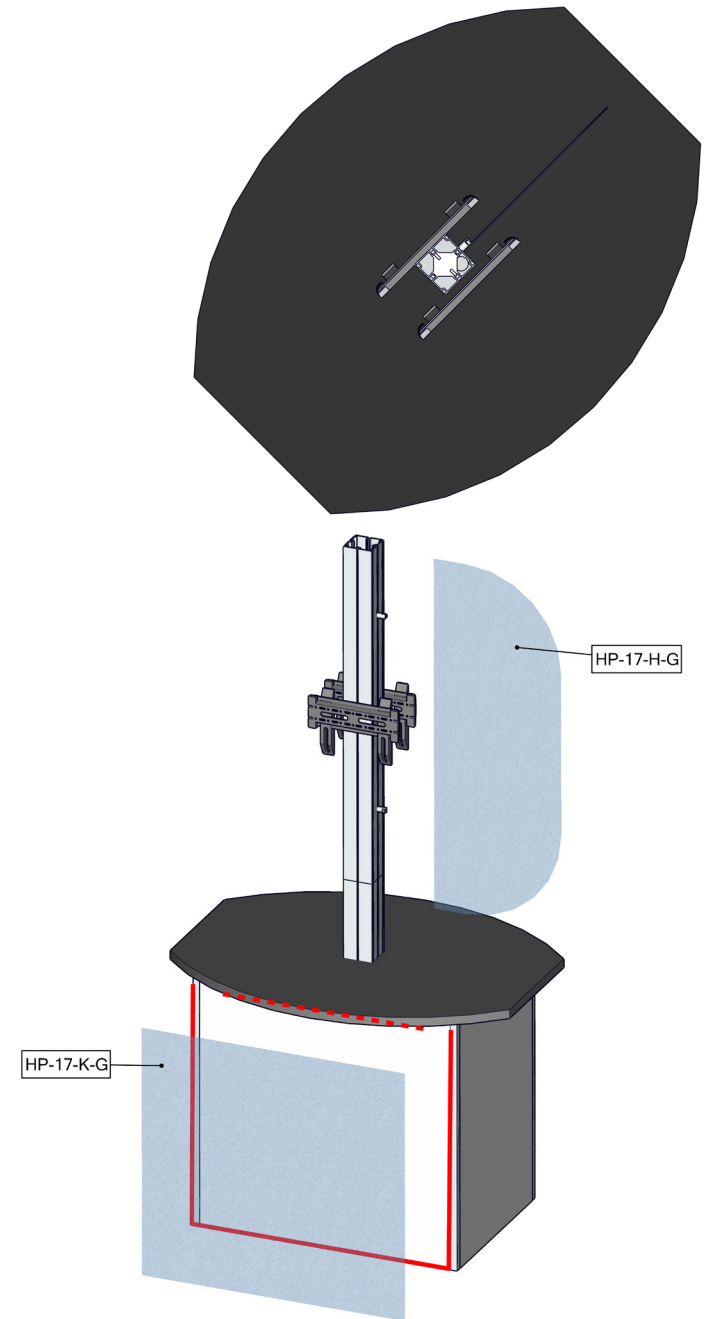
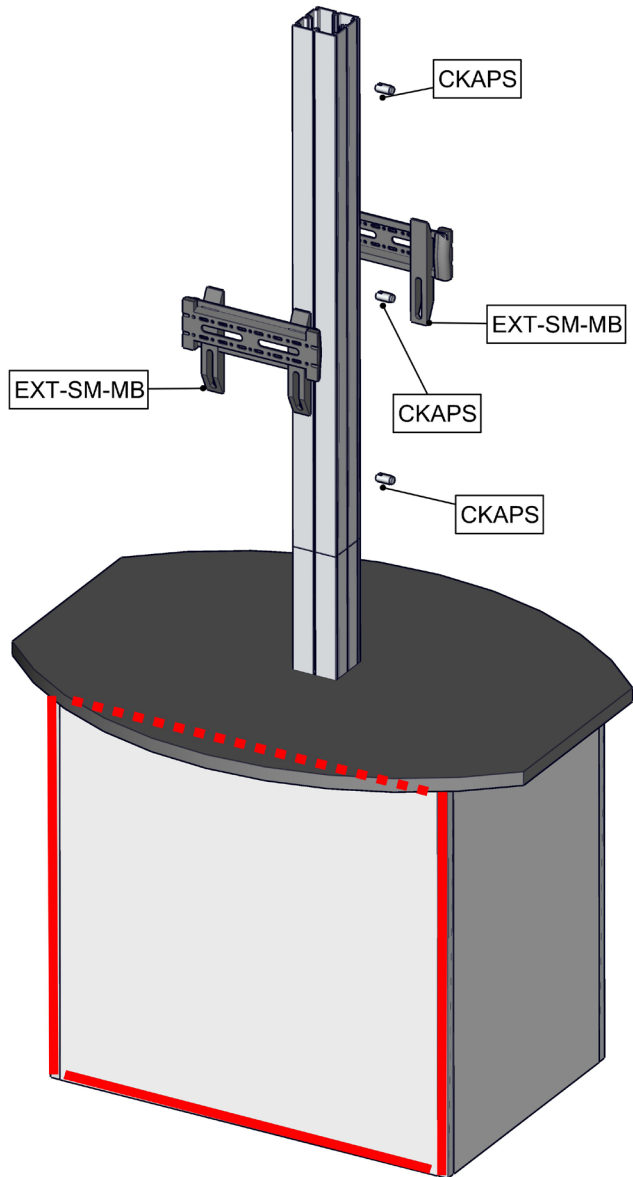

Exploded View

HP-K-17B

HP-FS-5

Reference the Suggested Layout page for build location.

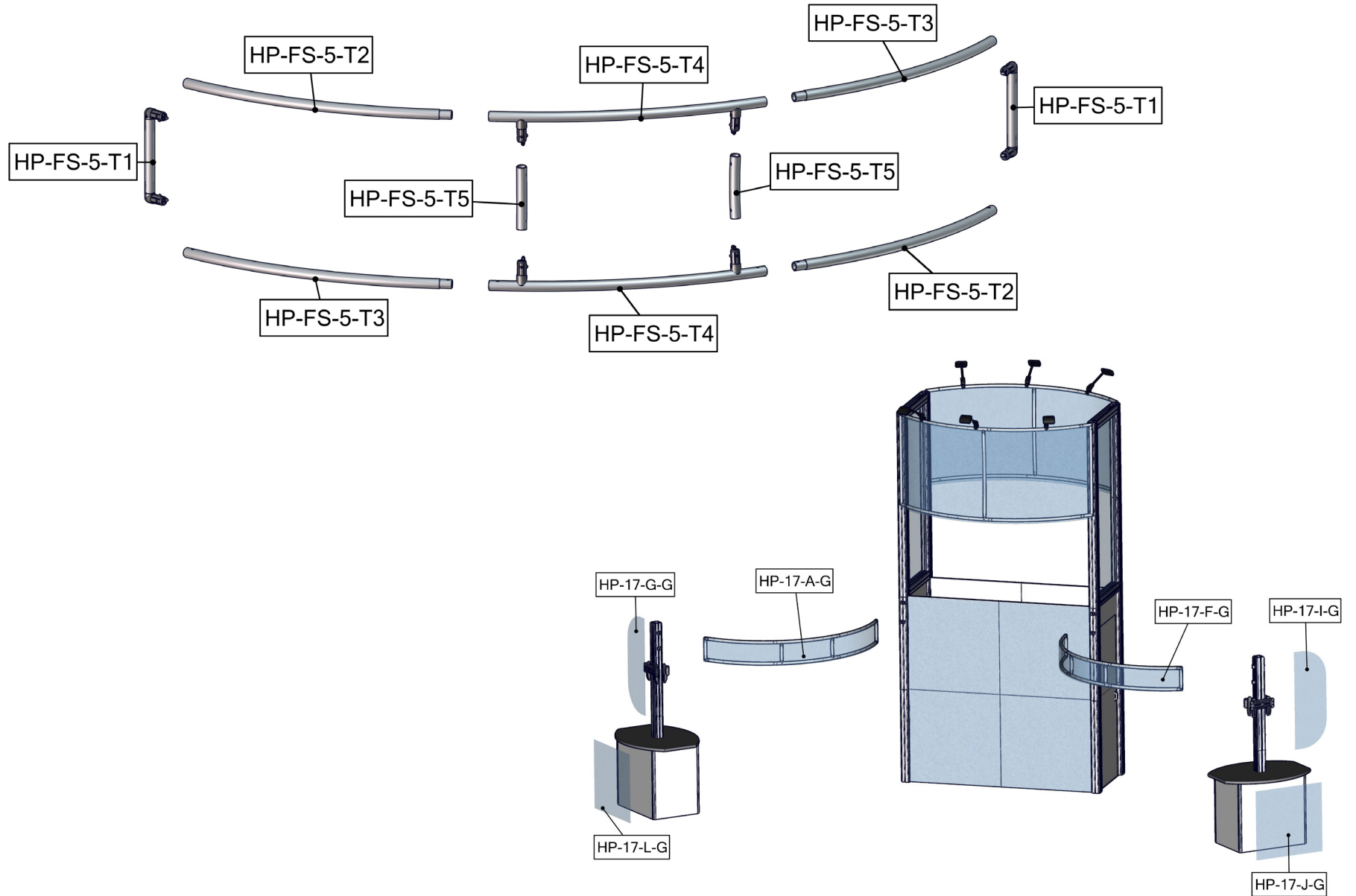

Labeling Diagram

HP-K-17B
HP-FS-5

Reference the Suggested Layout page for build location.

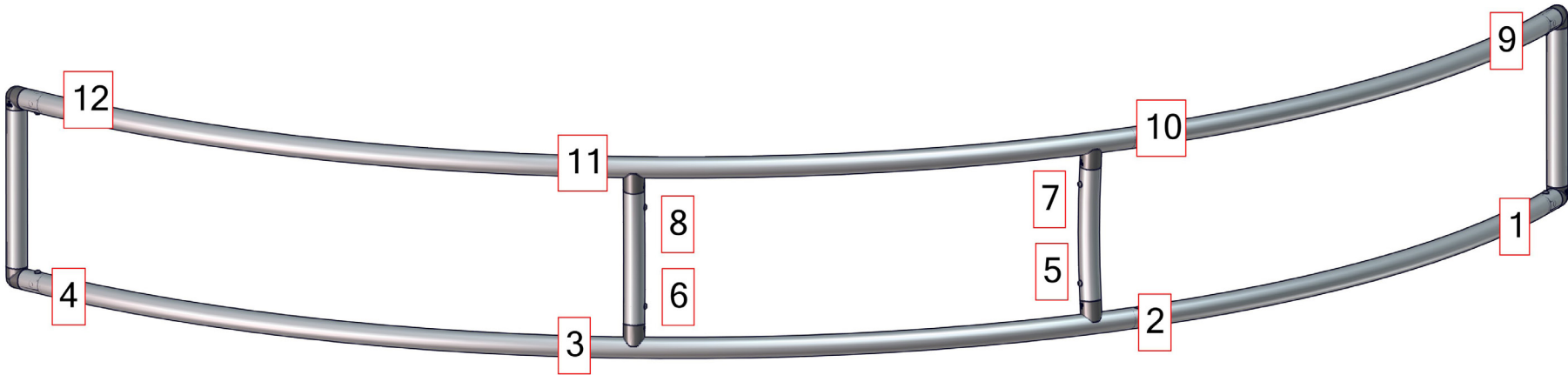

Suggested Layout

HP-K-17B

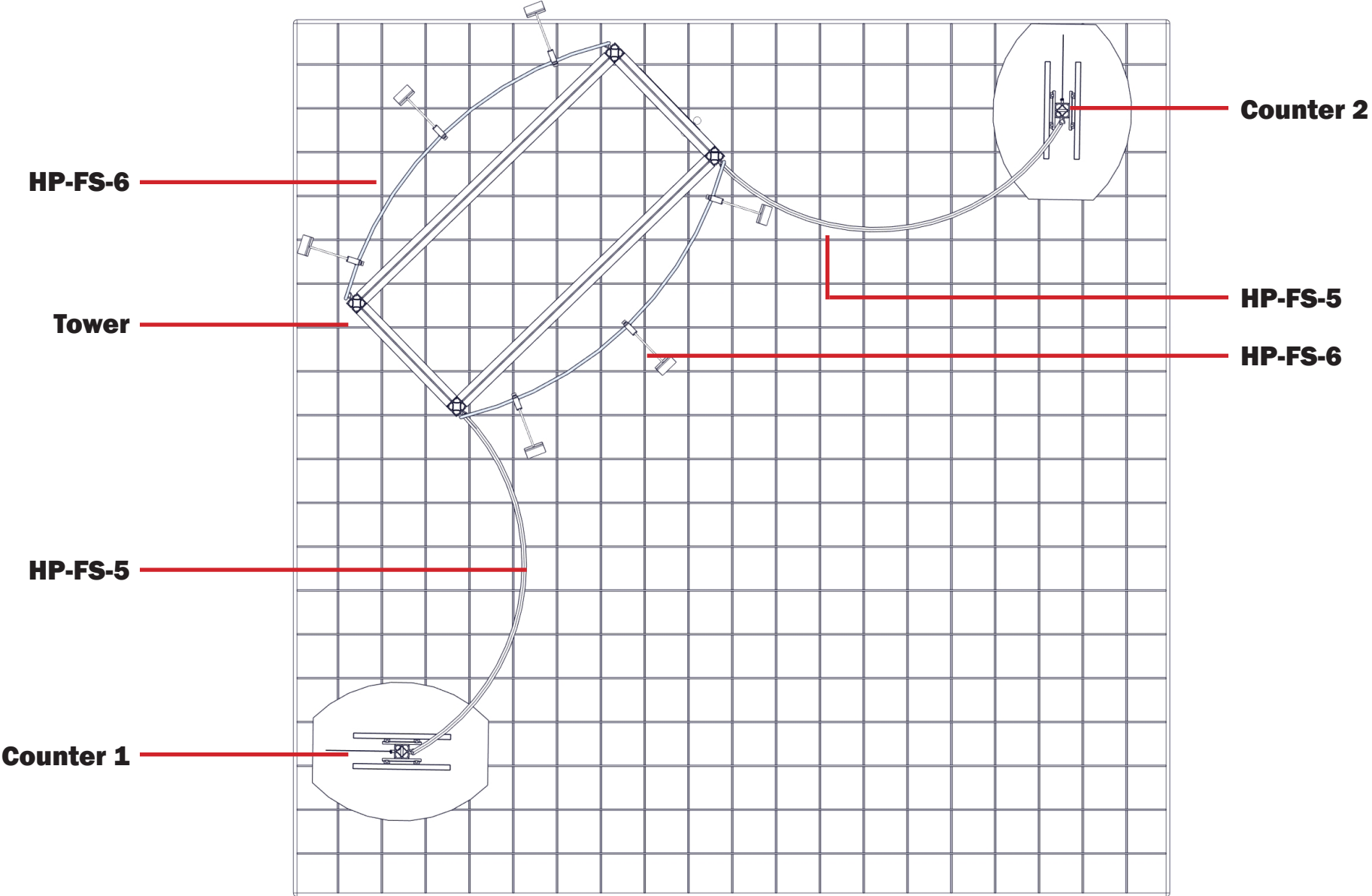

Connection Methods

Connection Method 1: CB9

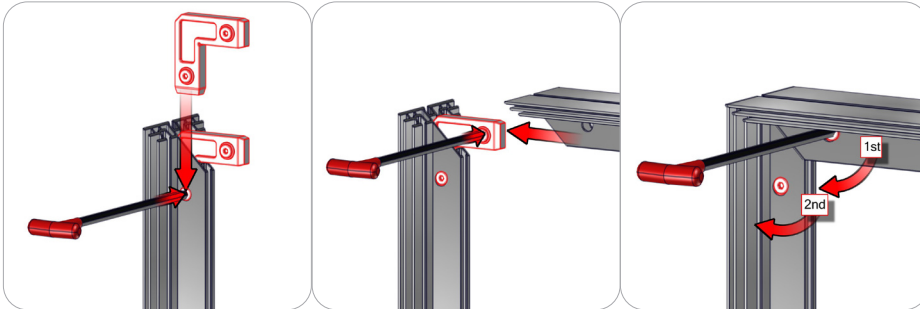

First, insert the corner connector into the extrusion while holding in the lock button with the allen key tool. Second, slide the next extrusion onto the same corner connector while holding in the lock button using the allen key tool. Third, use the allen key tool for locking the corner connector buttons in place. Use the allen key tool to make half turns clock-wise. Do not over tighten the lock buttons.

Connection Method 2: IB2

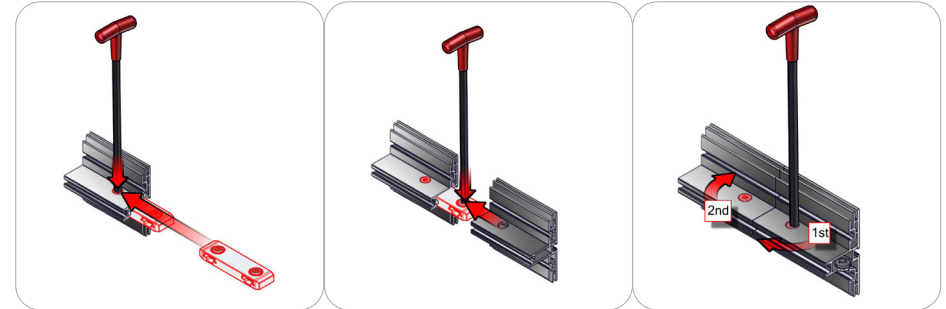

First, insert the in-line connector into the extrusion while holding in the lock button with the allen key tool. Second, slide the next extrusion onto the same in-line connector while holding in the lock button using the allen key tool. Third, use the allen key tool for locking the in-line connector buttons in place. Use the allen key tool to make half turns clock-wise. Do not over tighten the lock buttons.

Connection Method 3: CAM LOCK

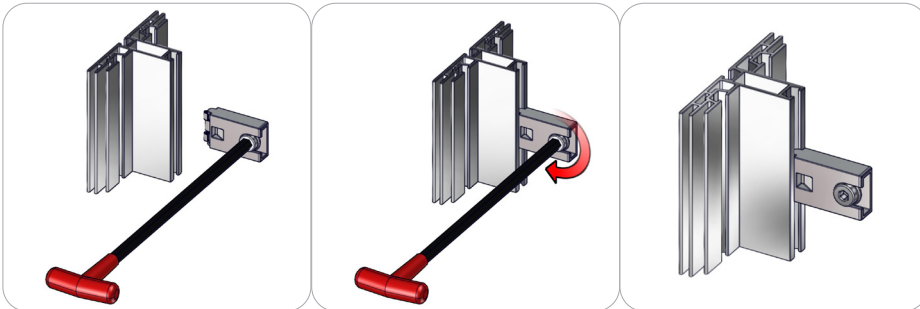

First, place the cam lock teeth into the desired extrusion channel. Second, use the allen key tool to lock the cam buttons in place. Make half turns clock-wise to engage the cam-lock. Do not over tighten the lock buttons.

Connection Method 4: Link Profiles

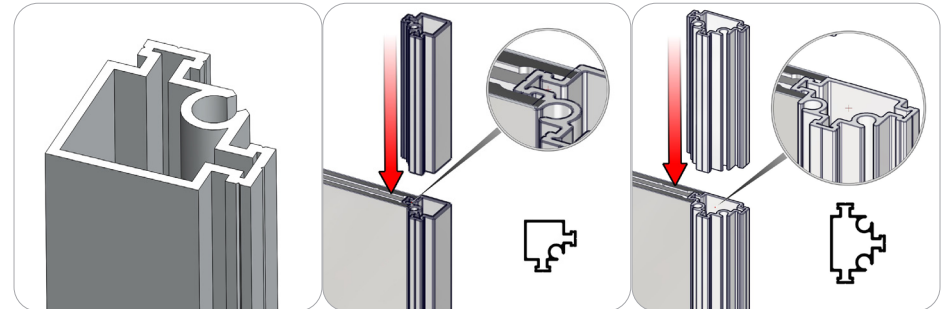

Take the link profile extrusion and slide it into the channel of the next component. There maybe tension glides in that channel, they will help hold the link in place. Make sure the link profile connection is flush at both ends.

Connection Methods

Connection Method 5: TC-30

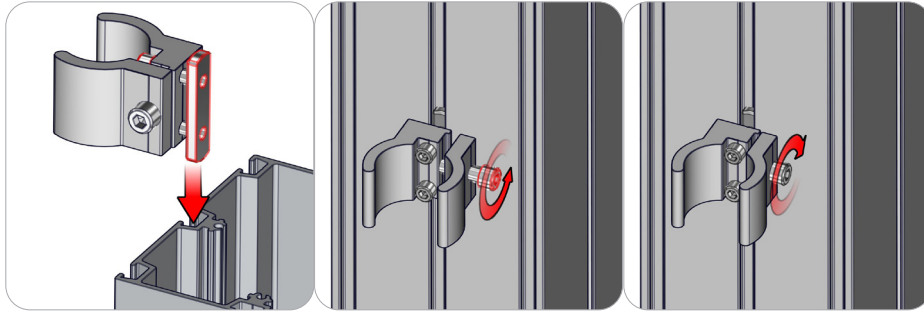

First, loosen the channel bar with the two set screws on the inside of the tube clamp. Do not disassemble it. Slide the clamp channel bar into the desired extrusion channel. Once it is in the desired location, tighten the channel bar screws. Second, loosen the clamp with the side set screw. Do not disassemble it.

Connection Method 6: PM4D-600-TG

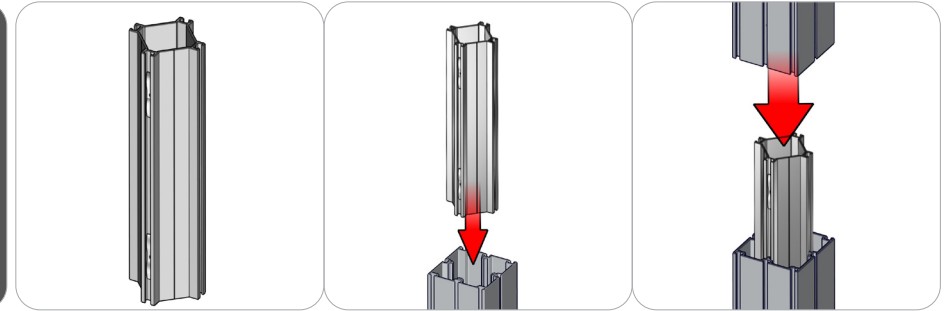

First, take the PM4DSC connector and align it with the internal channels of the next extrusion. Second, slide the connector into the inside channels of the extrusion. The tension glides on the connector will keep it center and snug. The extrusion will have stop pins pre installed to stop it from sinking in. Third, take the next extrusion and apply it on top of the connector completing your connection.

Connection Method 7: PLT-BP-PM4

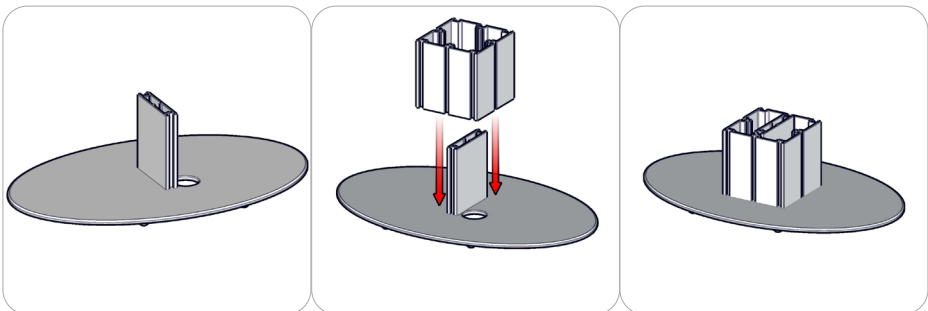

Slide the extrusion post onto the PH2 upright of the base plate. There maybe tension glides in that channel, they will help hold the post in place. Also, the base plate may have a hole for wire management.

Connection Method 8: CKAPS

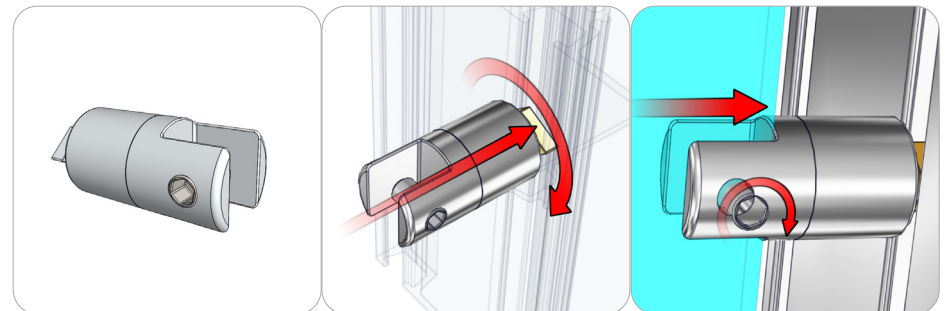

First, screw the CKAPS, clockwise, into the channel until it is tight. Loosen the head screw and make sure the slit in the head is running the correct direction, then tighten back into place. Second, loosen the hex bolt screw and insert the SINTRA and tighten into place. Do not over tighten.

Connection Methods

Connection Method 9: ES30 / ES50 / SNAP BUTTONS

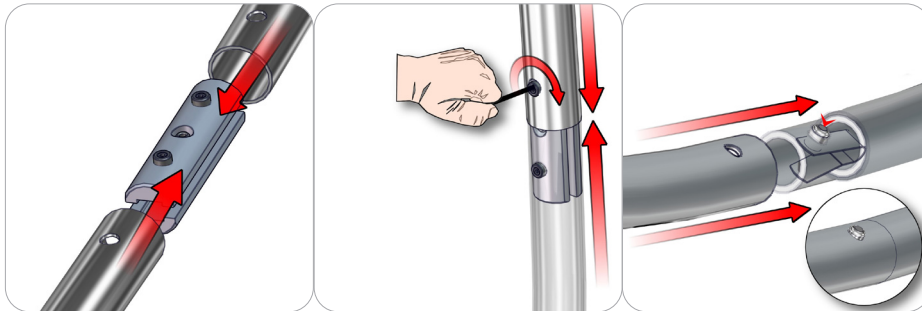

For spigot connections, compress the unlocked connector and slide into the tube lock access hole. Lock both screws carefully using your allen key tool. Be sure to lock securely, but do not over tighten. For snap button connections, locate the snap button on the connector or swage tube. Locate the hole on the corresponding tube. Press the snap button with your thumb and slide the tube and connector together so that the snap button snaps fully into the lock hole. To disassemble, press the snap button and pull apart.

Connection Method 10: FC Channel Graphic Application

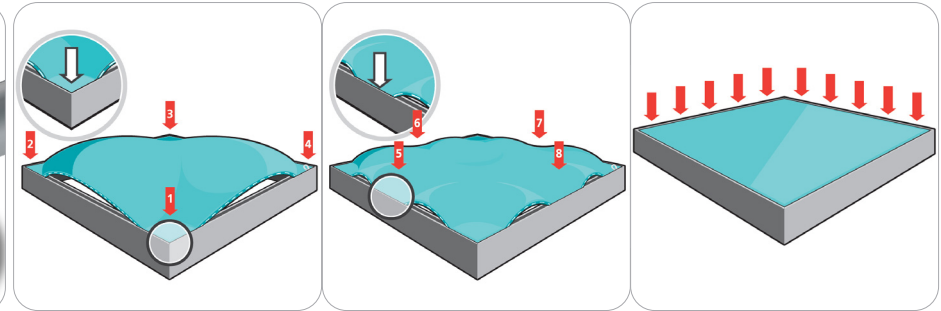

First, insert the silicone edge frame corners into the frame graphic channel (points 1 through 4). Second, insert the silicone edge frame sides into the frame graphic channel (points 5 through 8). Third, push the remaining silicone edge fabric into the frame graphic channel. Similar setup is recommended for the opaque liner. To remove these panels, simply pull the loop tag sewn near a corner.

Connection Method 11: SS1-1

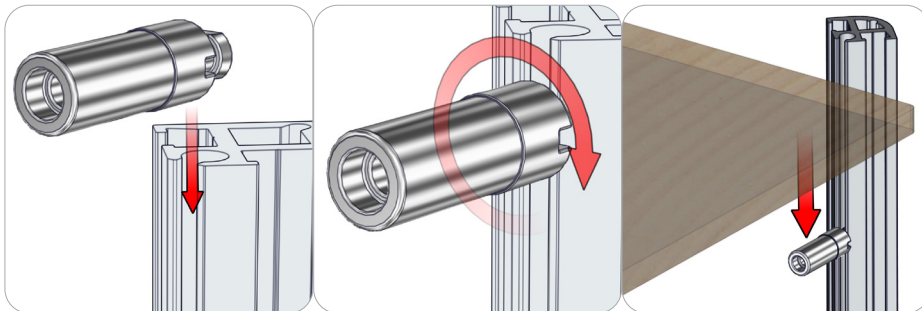

First, take the shelf support and loosen the set screw to about a 1/4 inch gap. Do not remove it. Second, slide the shelf support into the 3mm center channel. Turn the shelf support clock wise to lock it in place. Third, rest the shelf onto the shelf support. Loosen the shelf support to adjust and level.

Connection Method 12: CAM LOCK CONNECTION

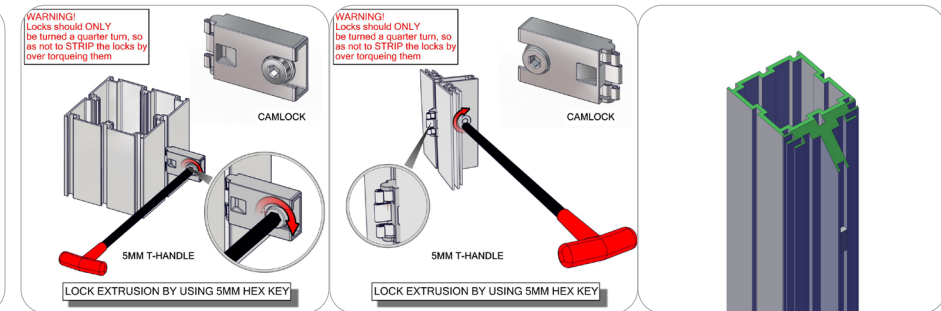

For spigot connections, compress the unlocked connector and slide into the tube lock access hole. Lock both screws carefully using your allen key tool. Be sure to lock securely, but do not over tighten. For snap button connections, locate the snap button on the connector or swage tube. Locate the hole on the corresponding tube. Press the snap button with your thumb and slide the tube and connector together so that the snap button snaps fully into the lock hole. To disassemble, press the snap button and pull apart.

Kit Assembly

Step by Step

Step 1.

Gather the components to build both vector frames. Use the Exploded View for part labels and reference the Suggested Layout page for build location.

Reference Connection Method(s) 1 and 3 for more details.

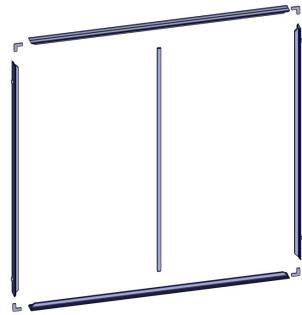
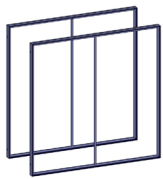

Step 2.

Gather the components to build right side door wall. Use the Exploded View and part labels and reference the Suggested Layout page for build location.

Reference Connection Method(s) 2 and 3 for more details.

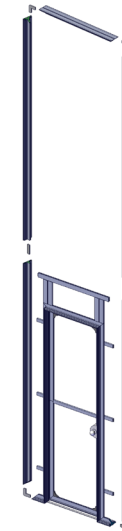

Step 3.

Gather the components to build the left side wall. Use the Exploded View for part labels and reference the Suggested Layout page for build location.

Reference Connection Method(s) 1, 2 and 3 for more details.



Step 4.

Gather the components to build side supports. Use the Exploded View for part labels and reference the Suggested Layout page for build location.

Reference Connection Method(s) 6 and 13 for more details.

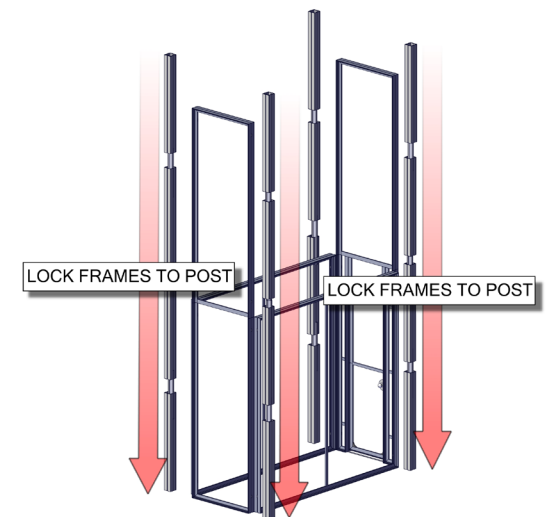

Kit Assembly

Step by Step

Step 5.

Gather the components to attach tc-30 to frame. Use the Exploded View for part labels and reference the Suggested Layout page for build location.

Reference Connection Method(s) 5 for more details.

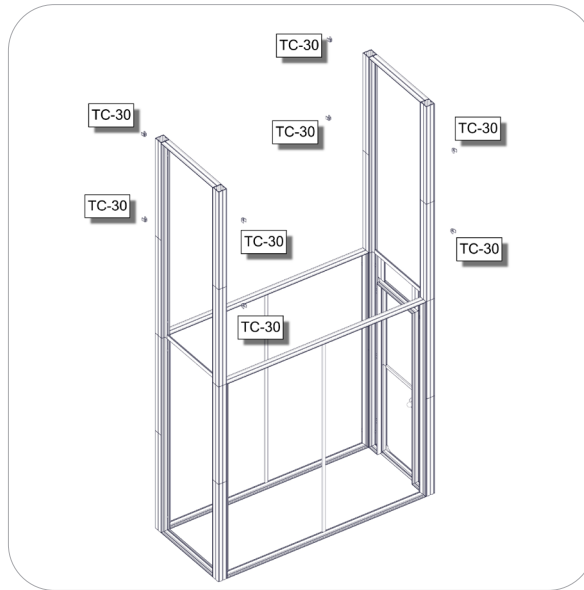

Step 6.

Gather the components to build the center of the HP-FS-6 frame. Use the Exploded View and the Labeling Diagram. Make 2.

Reference Connection Method(s) 9 for more details.

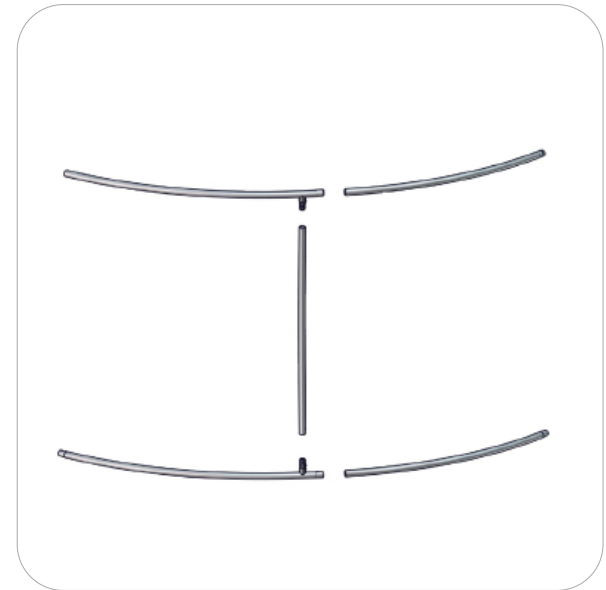

Step 7.

Gather the components to build the ends of the HP-FS-6 frame. Use the Exploded View and the Labeling Diagram. Make 2.

Reference Connection Method 8 for more details.

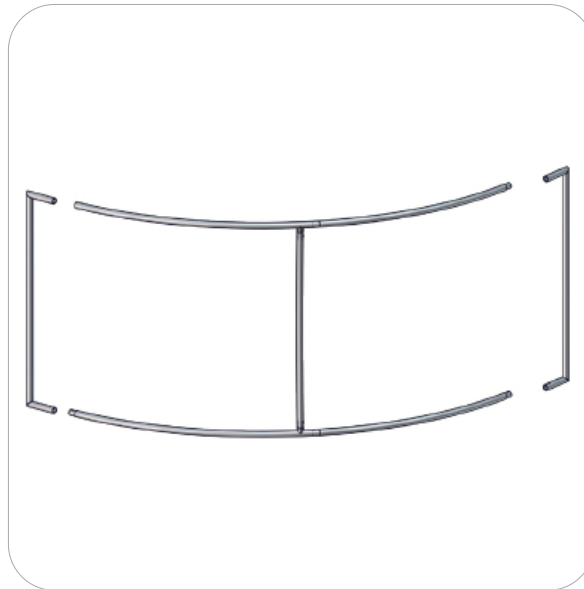

Step 8.

Apply the pillow case over the HP-FS-6 frame. Zipper it closed at the bottom. Make 2.

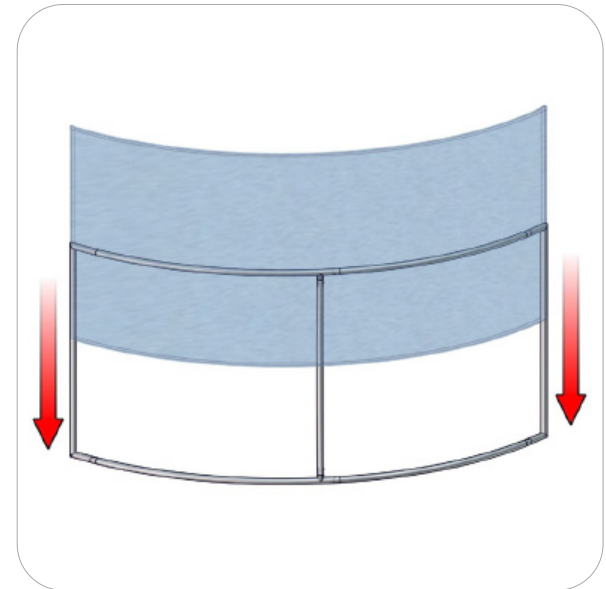
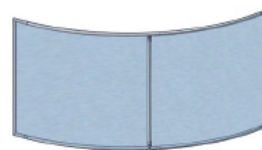

Kit Assembly

Step by Step

Step 9.

Use the tube clamps for attaching the HP-FS-6 headers onto the tower. Use the Exploded View for part labels and reference the Suggested Layout page for build location.

Reference Connection Method(s) 5 and 7 for more details.

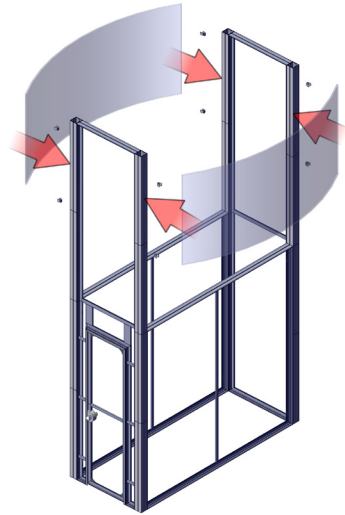

Step 10.

Attach the spot lights with the provided clamps on the HP-FS-6 headers. Use the Exploded View for part labels and reference the Suggested Layout page for build location.



Step 11.

Attach front and back graphics to door frame.

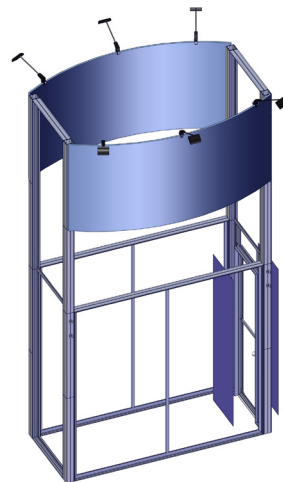
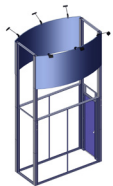

Step 12.

Attach front and back graphics to both vector frames. First, insert the silicone edge frame corners into the frame graphic channel. Second, insert the silicone edge frame sides into the frame graphic channel. Third, push the remaining silicone edge fabric into the frame graphic channel.

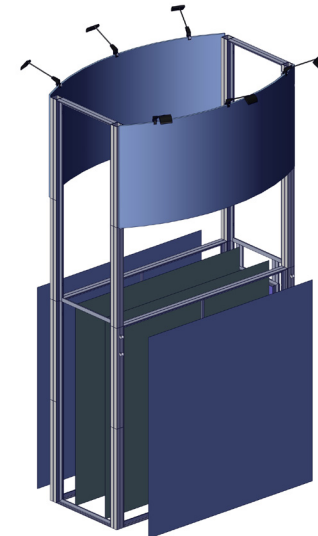
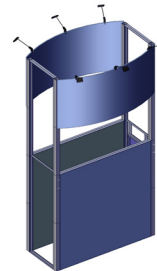

Kit Assembly

Step by Step

Step 13.

Attach front and back graphics for side walls. First, insert the silicone edge frame corners into the frame graphic channel. Second, insert the silicone edge frame sides into the frame graphic channel. Third, push the remaining silicone edge fabric into the frame graphic channel.

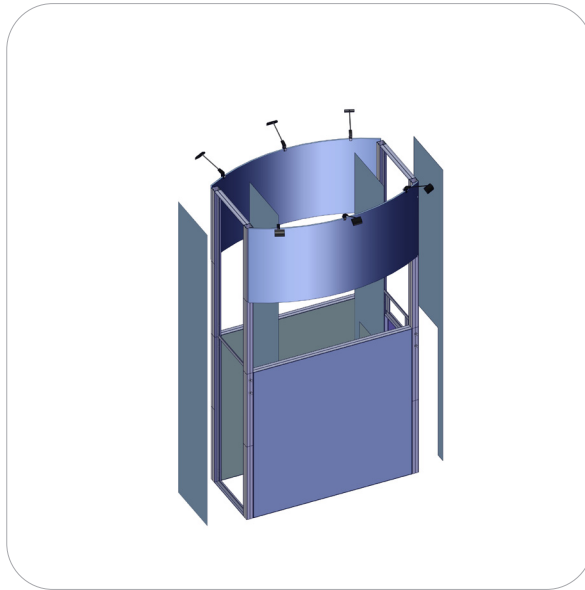
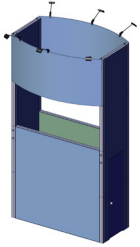

Step 14.

Gather the components to build the counter cabinet. Use the Exploded View and part labels and reference the Suggested Layout page for build location. Make 2. Reference Connection Method(s) 4 and 12 for more details.

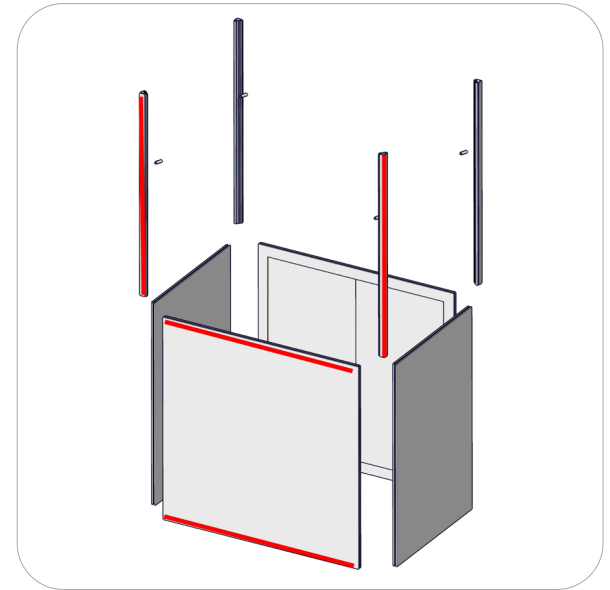
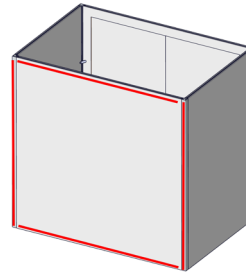

Step 15.

Gather the components to build the counter internal supports. Use the Exploded View 2.2 for part labels. Make 3.

Reference Connection Method(s) 7 for more details.

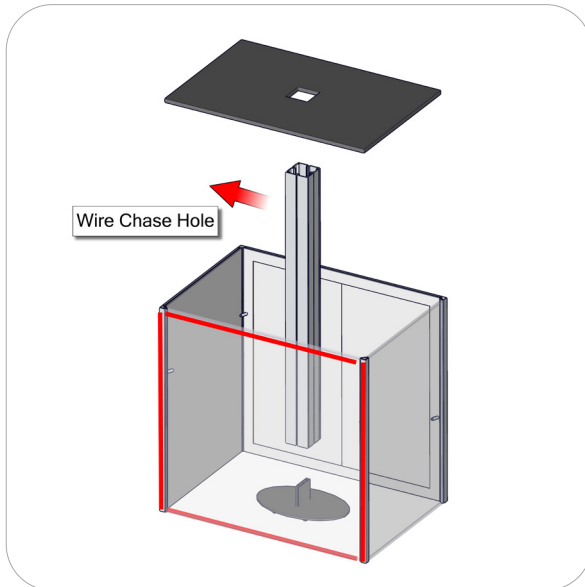

Kit Assembly

Step by Step

Step 16.

Gather the components to build the counter top and post. Use the Exploded View 2.3 for part labels. Make 3.

Reference Connection Method(s) 6 for more details.

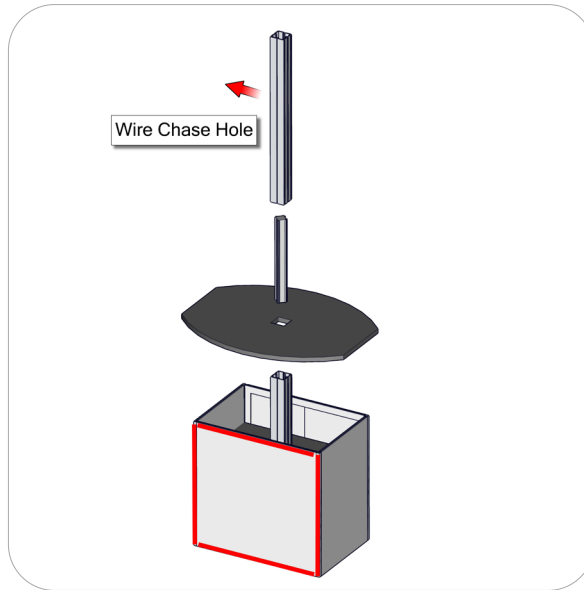
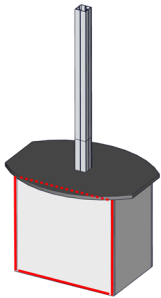

Step 17.

Attach the monitor mounts, wing clamps and tube clamps. Use the Exploded View and part labels. Reference Connection Method(s) 5 and the monitor mount supplemental sheets for more details.

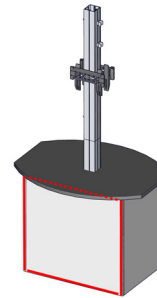

Counter 1

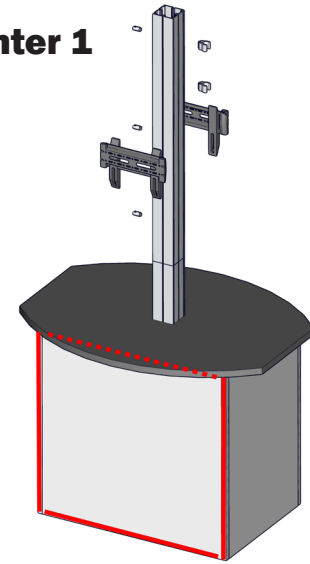

Step 18.

Attach the monitor mounts, wing clamps and tube clamps. Use the Exploded View and part labels. Reference Connection Method(s) 4, 8 and the monitor mount supplemental sheets for more details.

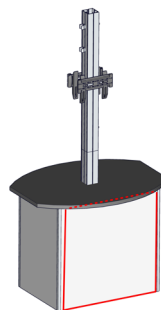

Counter 2

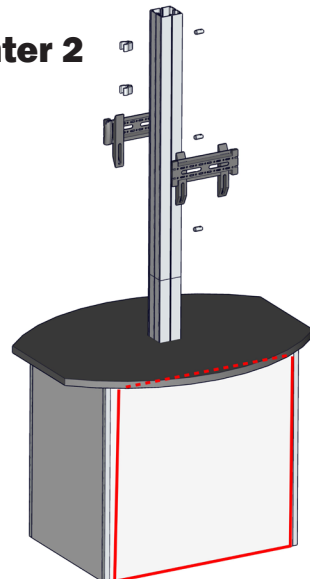

Kit Assembly

Step by Step

Step 19.

Gather the components to build the center of the HP-FS-5 frame. Use the Exploded View and the Labeling Diagram and part labels. Make 2.

Reference Connection Method 9 for more details.

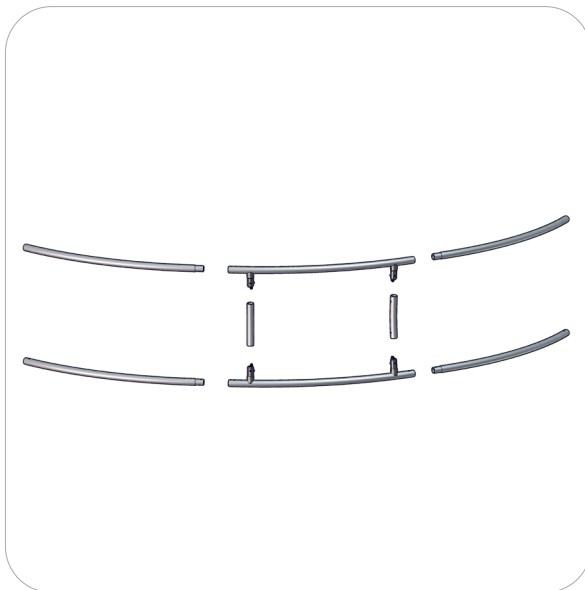

Step 20.

Gather the components to build the ends of the HP-FS-5 frame. Use the Exploded View and the Labeling Diagram 3.1 for part labels. Make 2.

Reference Connection Method 89 for more details.



Step 21.

Apply the pillow case over the HP-FS-5 frame. Zipper it closed at the bottom. Make 2.

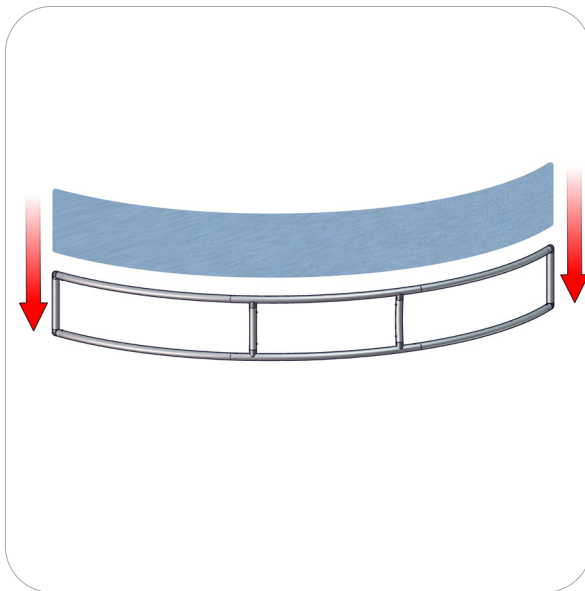

Step 22.

Use the tube clamps for attaching the HP-FS-5 headers onto the tower and Counters 1 and 2. Use the Exploded View for graphic locations.

Reference Connection Method(s) 4 for more details.

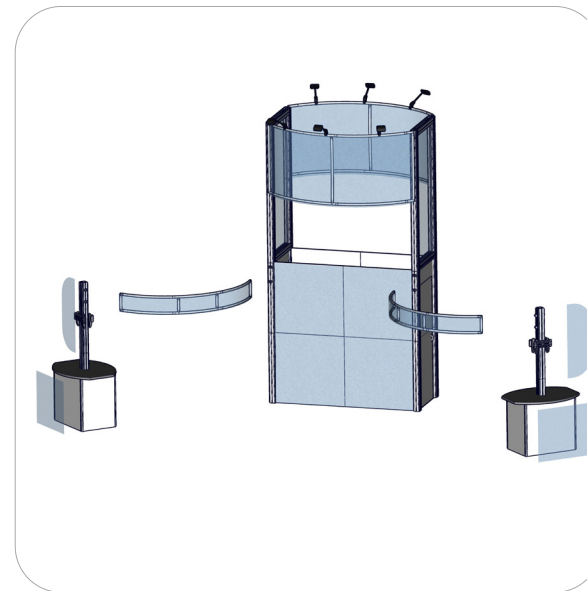
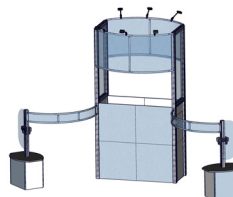

Kit Assembly

Step by Step

Step 23.

Attach the graphic panels onto counter 1. Use the Exploded View 3.1 for graphic labels.

Reference Connection Method 13 for more details.

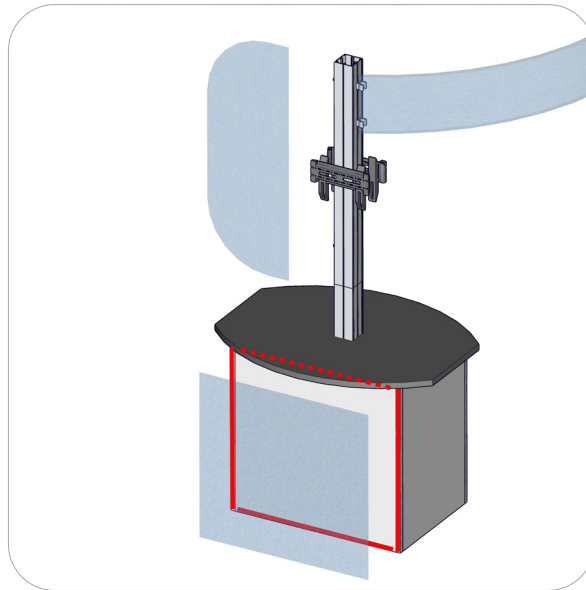
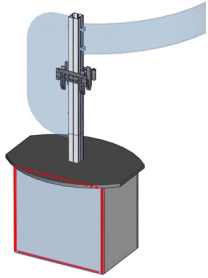

Step 24.

Attach the graphic panels onto counter 2. Use the Exploded View 3.1 for graphic labels.

Reference Connection Method 13 for more details.

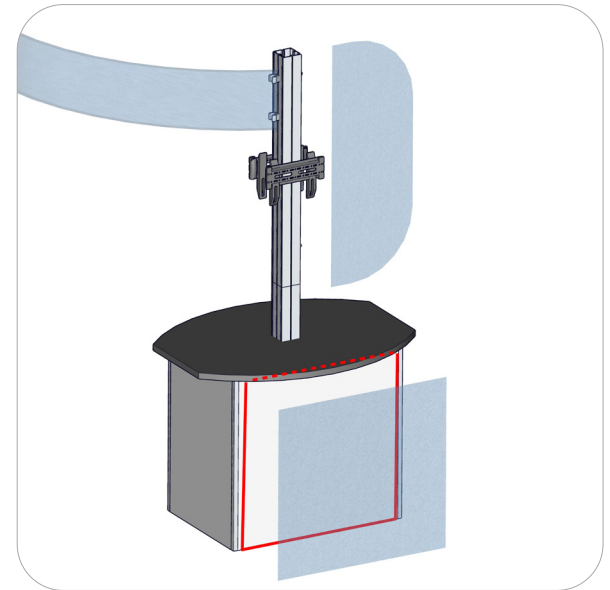
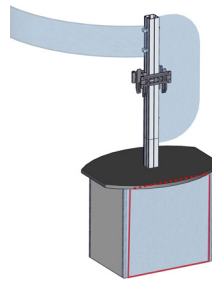

Step 25.

Connect the power supplies for the spotlights and attach your monitors onto the monitor mounts brackets.

Setup is complete.

