

MODify Double Sided Kit 02

MODify™ is a one-of-a-kind Modular Merchandising System that is made up of interchangeable fixtures and accessories that can be easily assembled, disassembled, and rearranged to create a variety of different display configurations. The MODify system incorporates SEG push-fit fabric graphics that enable you to brand, promote and merchandise with ease.

MODify Double Sided Kit 02 is a versatile retail display that includes four slatwall panels, two on front, two on back, and four SEG push-fit graphic panels, two on front and two on back. Customize and MODify this kit by adding accessories such as shelves, hooks, waterfalls, monitor mounts, bars and more.



We are continually improving and modifying our product range and reserve the right to vary the specifications without prior notice. All dimensions and weights quoted are approximate and we accept no responsibility for variance. E&OE. See Graphic Templates for graphic bleed specifications

features and benefits:

Base Kit includes:

- Frame, slatwall, shelf and base colors in kit are all the same, your choice of all white, black, or silver
- Heavy-duty aluminum frame, steel base
- Steel, slotted uprights
- Four 36"W x 48"H slatwall panels, two on the front & two on the back
- Four 35"W x 47"H SEG, push-fit graphic panels, two on the front & two on the back
- Non-rolling Base
- Display is easy to assemble and install
- Lifetime hardware warranty against manufacturer defects

Optional Accessories Include:

- Monitor Mount
- U bars
- Slatwall hooks
- Shelves
- Towel bars
- Faceout bars
- Waterfalls

dimensions:

Hardware	Shipping
<p>Assembled unit:</p> <p>74"W x 96"H x 37.5"D 1879.6mm(w) x 2438.4mm(h) x 952.5mm(d)</p> <p>Approximate Weight: 202 lbs / 91.6257 kg</p>	<p>Packing case(s): 1 Box</p> <p>Shipping dimensions: (96"L x 14"H x 24"D) 2438.4mm(l) x 355.6mm(h) x 609.6mm(d)</p> <p>Approximate shipping weight: 265 lbs / 120.202 kg</p>

additional information:

Graphics

Graphic material: Dye-sublimated fabric

See graphic templates for graphic sizes.

Refer to related graphic templates for more information Visit:

<https://www.theexhibitorshandbook.com/downloads/download-graphic-templates>
or click here

Powder coat color options:

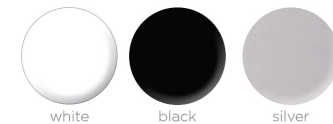

Wood laminate color options:

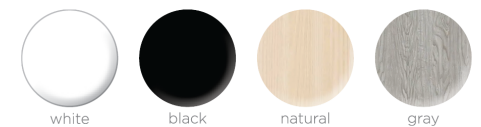

MODify Accessories

All Accessories available in white, black, or silver

Slotwall Accessories

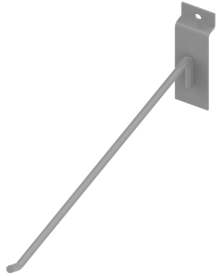

MFY-SLT-HK
4", 6", 8", 10" & 12"

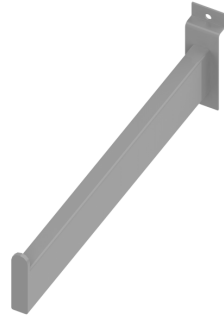

MFY-SLT-FC
6", 8", 10" & 12"

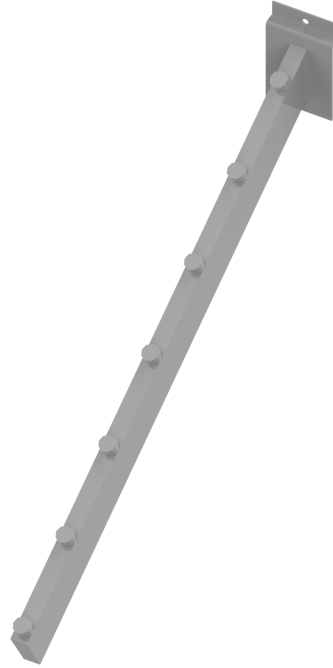

MFY-SLT-WTR-16-7

U-Bar Accessories

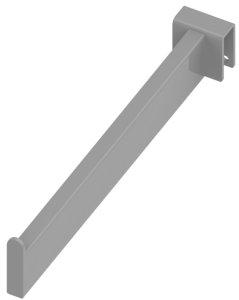

MFY-TWL-FC
6", 8" & 10"

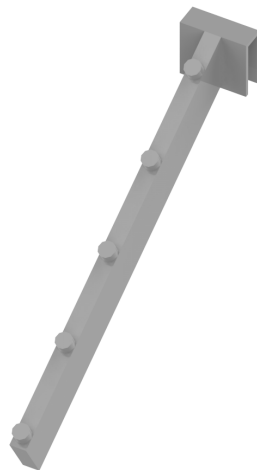

MFY-UBR-FC
6", 8" & 10"

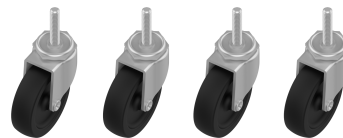

MFY-CSTR-4-PK

Shelf and Hanger Bars

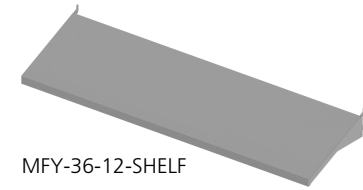

MFY-36-12-SHELF

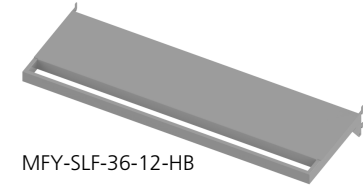

MFY-SLF-36-12-HB

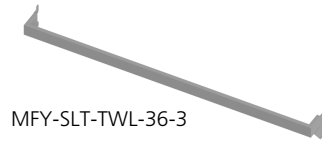

MFY-SLT-TWL-36-3

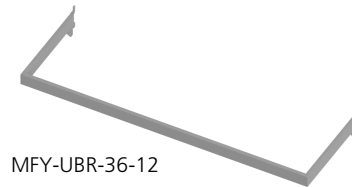

MFY-UBR-36-12

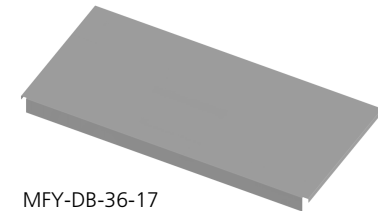

MFY-DB-36-17

Tools Required



MULTI HEX KEY
(INCLUDED)



PHILLIPS SCREW DRIVER
(NOT INCLUDED)



9/16" SOCKET WRENCH
(NOT INCLUDED)

How to Apply & Remove Graphics

Installation and removal of SEG graphics is easy!

Installation: Push the SEG bead into each corner of the frame (1-4) with your thumb, then push the SEG bead into the middle of the run (5-8) and work your way around the perimeter of the frame until all beading is pushed in properly; if necessary, go around the perimeter again to ensure beading is secure in the extrusion profile.

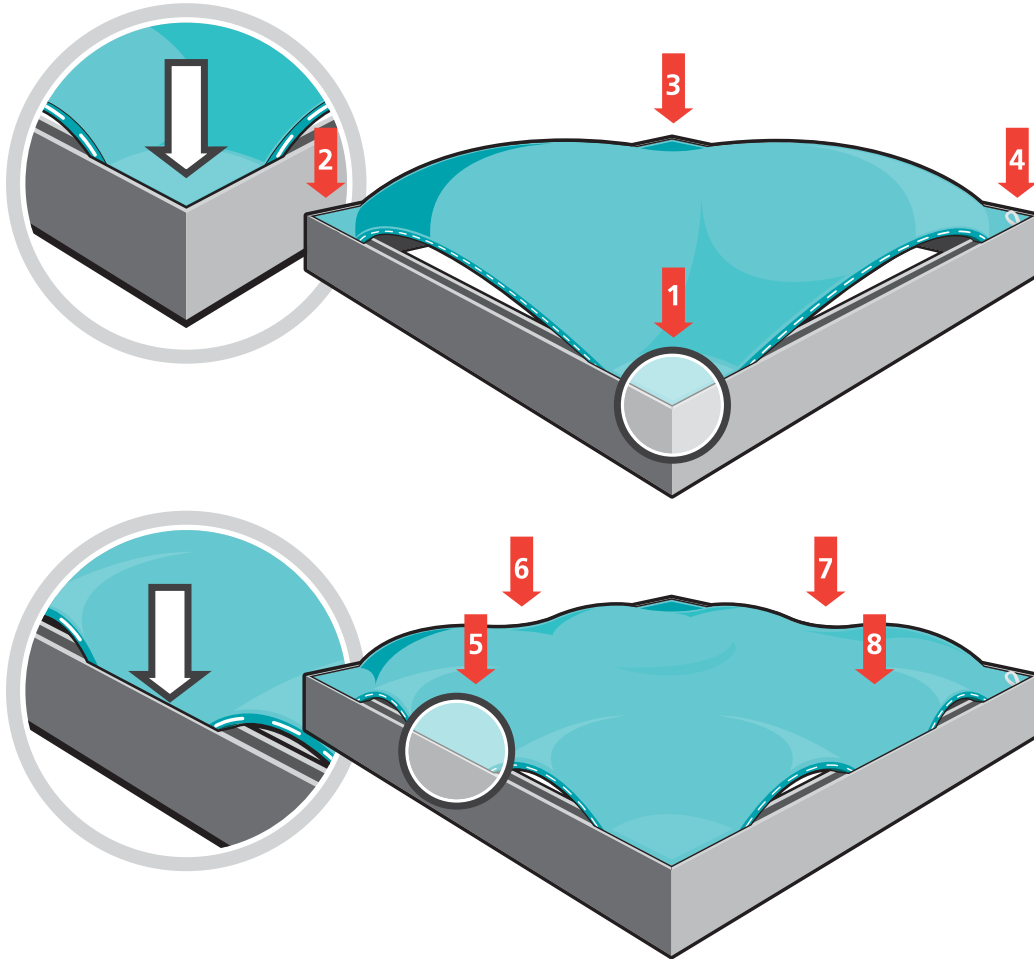





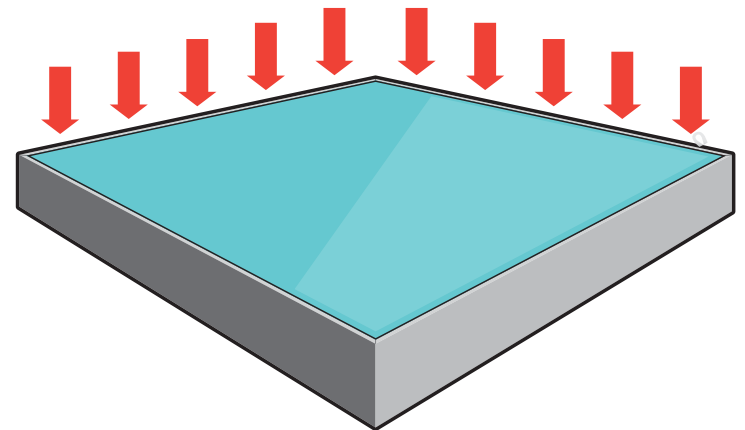



Note: Keep the set up area clean by using a drop cloth, washing hands before set-up or by wearing gloves.

Removal: Use the pull tab located on the graphic and gently pull the graphic from the frame, going around the perimeter.



Graphics Storage & Care

Graphics should be folded with the graphic facing inward and stored in a zip lock /sealable plastic bag. Spot clean by wiping with a damp white cloth. If washing is necessary, use a commercial size front-loading washing machine, gentle cycle with cool water. Line dry flat. Dry cleaning is NOT recommended to prevent shrinkage.

QTY	IMAGE	DESCRIPTION
3		3/8-16 x 2.5" L bolt
1		2350MM (92.52in) LEFT UPRIGHT
1		2350MM (92.52in) MIDDLE UPRIGHT
1		2350MM (92.52in) RIGHT UPRIGHT
1		947MM (37.28IN) MIDDLE SUPPORT LEG
1		947MM (37.28IN) LEFT SUPPORT LEG
4		1058MM (41.65in) OF SWC EXTRUSION
1		947MM (37.28IN) RIGHT SUPPORT LEG

SETUP INSTRUCTIONS

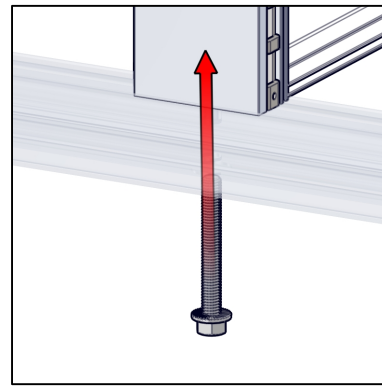
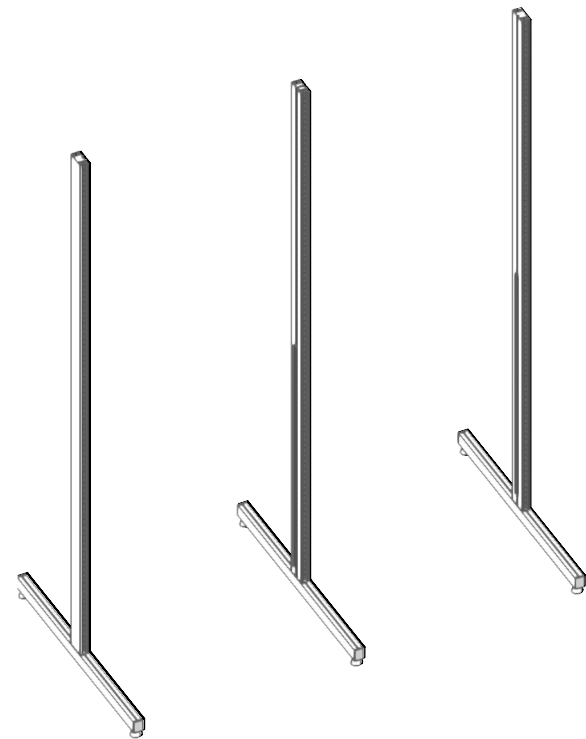

MFY-BOLT-375-16-2.5

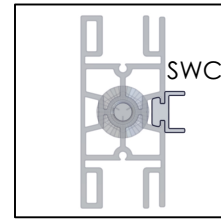
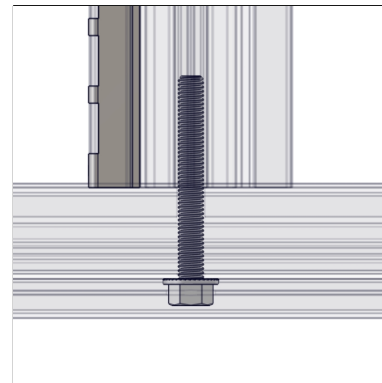

RIGHT UPRIGHT

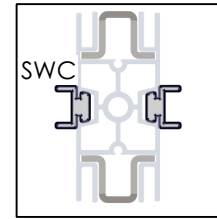

MIDDLE UPRIGHT

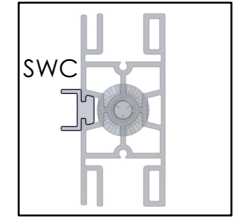

LEFT UPRIGHT

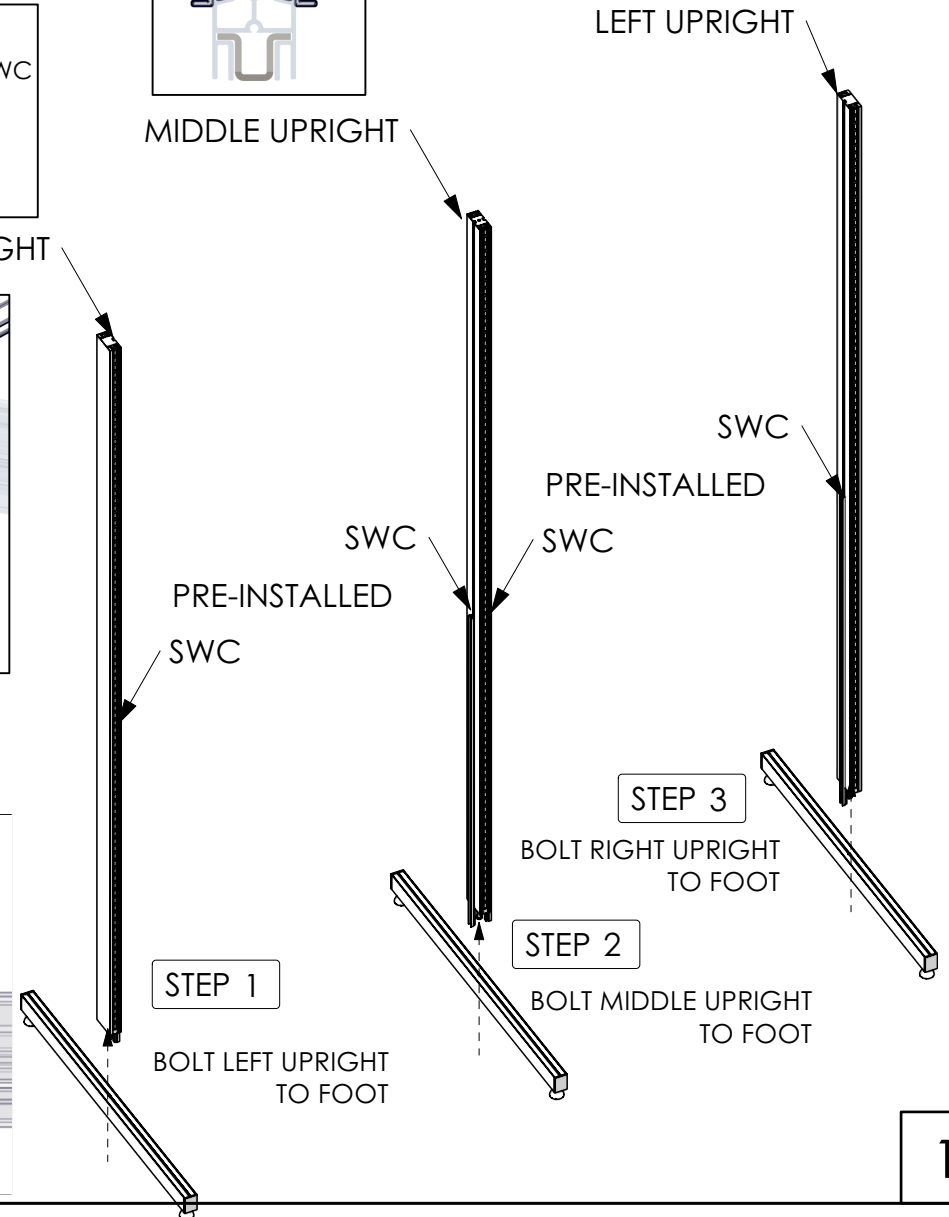

QTY	IMAGE	DESCRIPTION
2		883MM (34.7in) OF SINGLE SIDED SEG EXTRUSION -WITH CAM LOCKS BOTH ENDS
2		883MM (34.7in) OF SWC EXTRUSION

SETUP INSTRUCTIONS

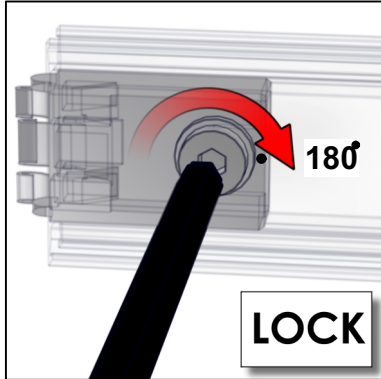

IMPORTANT! MAKE A HALF TURN TO LOCK EXTRUSIONS

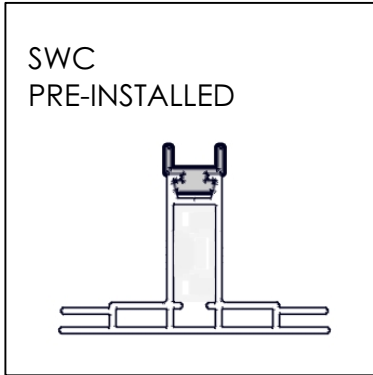

SWC
PRE-INSTALLED

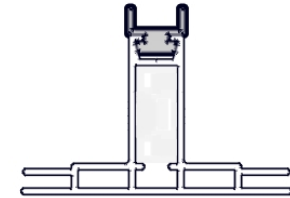

SLOT WALL TOP
CHANNEL

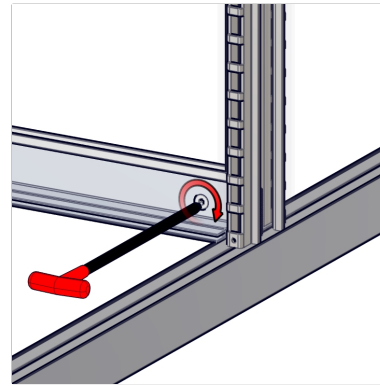

CROSS BRACE SITS ON SUPPORT LEGS

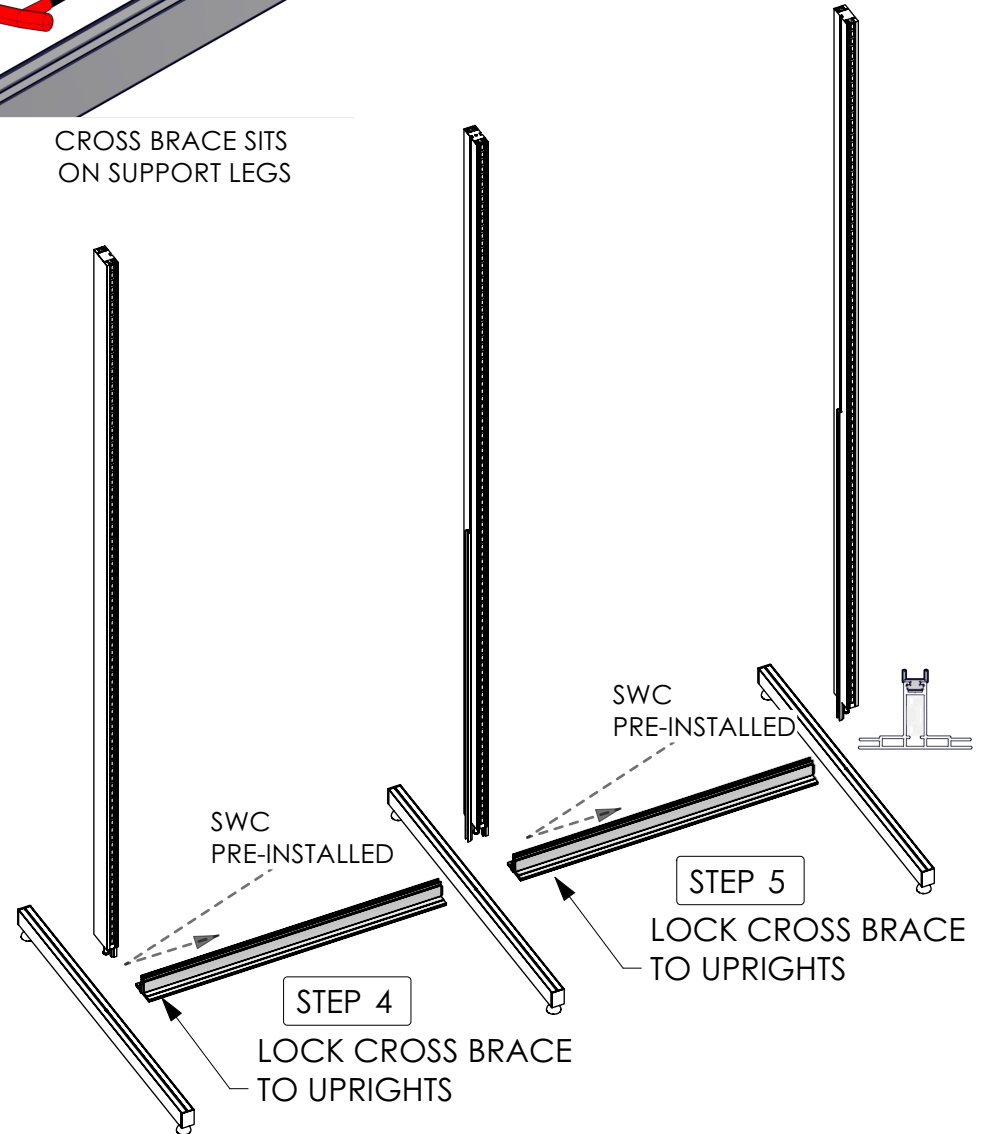
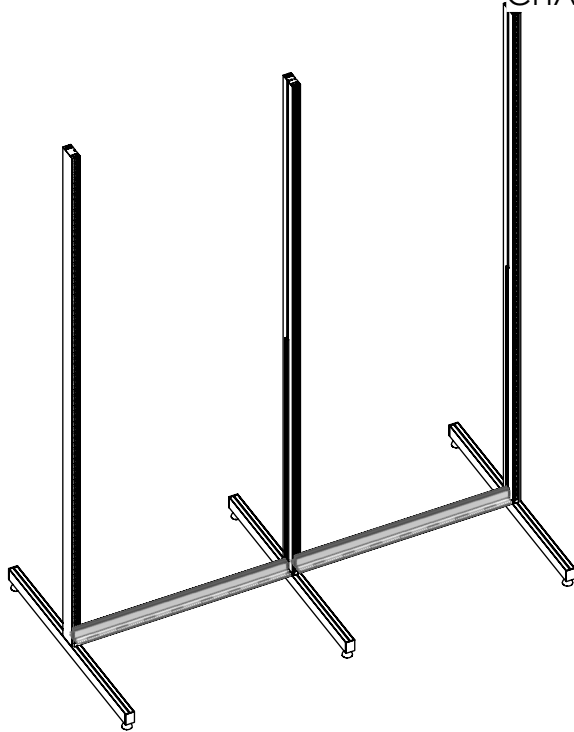

NOTE: BOTTOM CROSS BRACE SITS ON TOP INSIDE EDGE OF LEFT AND RIGHT SUPPORT LEG

QTY	IMAGE	DESCRIPTION
14		879MM (34.61in) LENGTH OF SLOTWALL EXTRUSION

SETUP INSTRUCTIONS

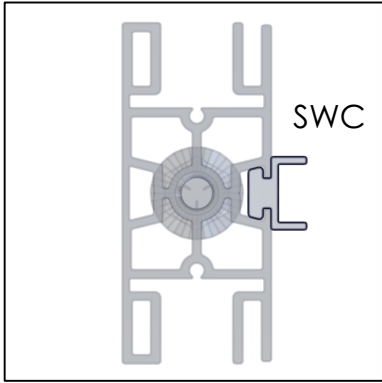

SLOTWALL CHANNEL

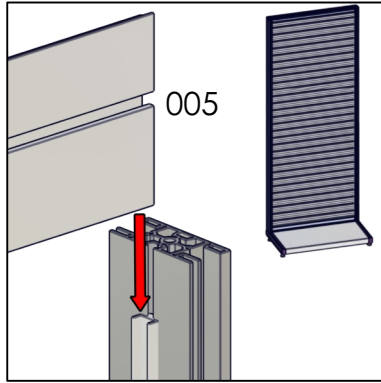

SLOTWALL EXTRUSION

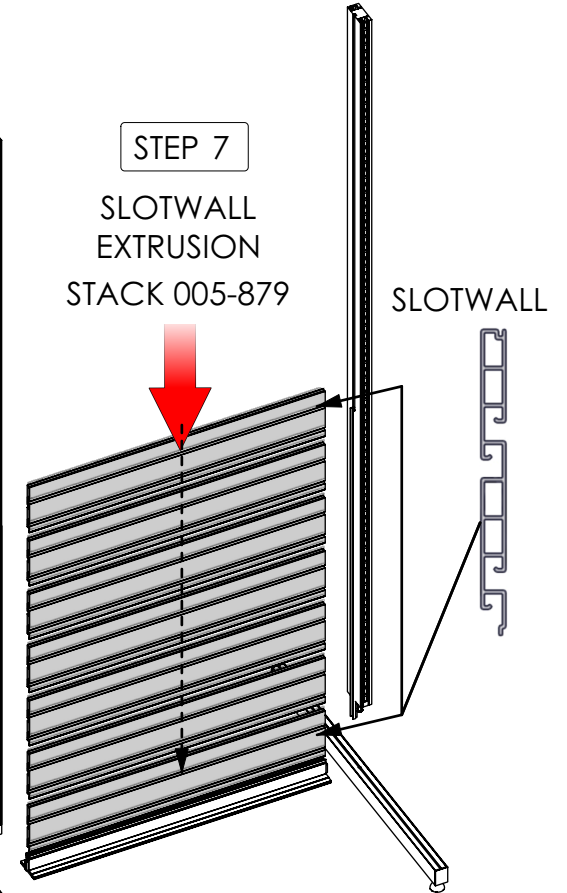
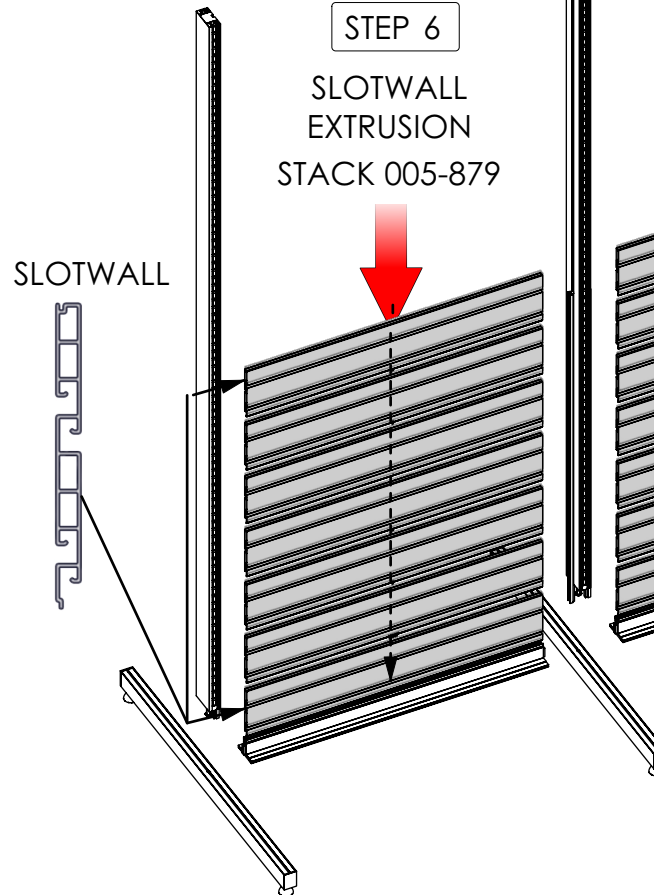
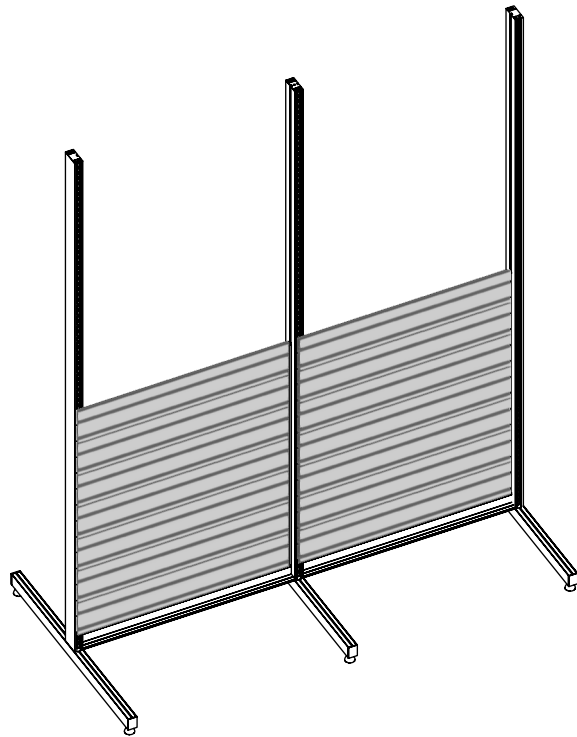
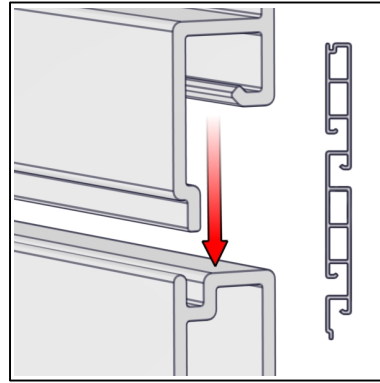

SETUP INSTRUCTIONS

4		883MM (34.76in) OF SINGLE SIDED SEG EXTRUSION -WITH CAM LOCKS BOTH ENDS
2		883MM (34.76in) OF SWC EXTRUSION
2		7MM SEG PLASTIC END CAP FOR 833 EXTRUSION
1		7MM SEG PLASTIC END CAP FOR 832 EXTRUSION

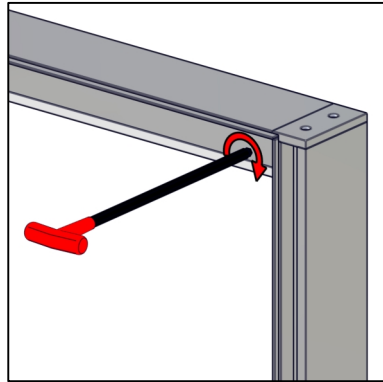
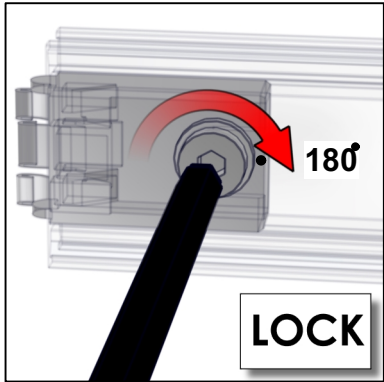

IMPORTANT! MAKE A HALF TURN TO LOCK EXTRUSIONS

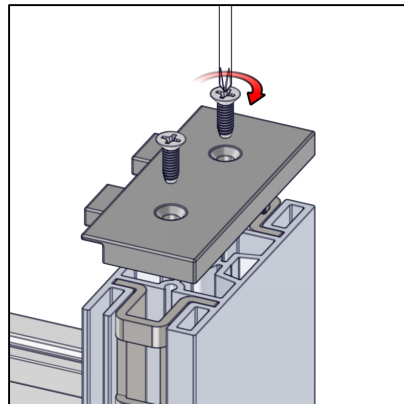
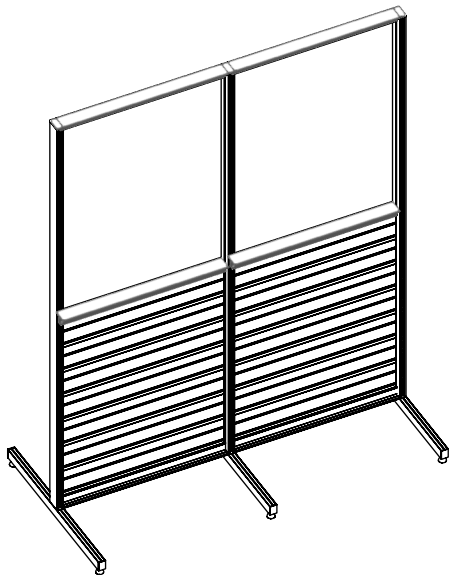

LOOSEN END CAP TO ATTACH TOP CROSS BRACE

STEP 10
LOCK CROSS BRACE TO UPRIGHTS AND PLACE END CAPS

STEP 11

LOCK CROSS BRACE TO UPRIGHTS AND PLACE END CAPS

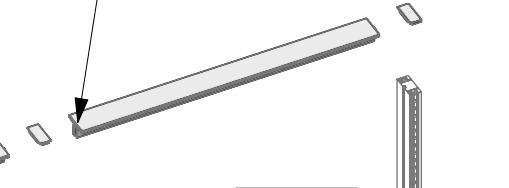
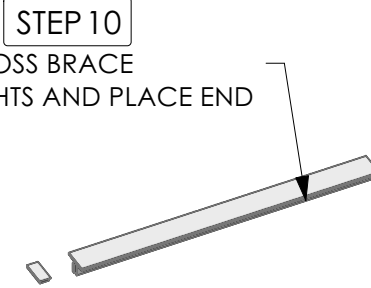

STEP 8

LOCK CROSS BRACE TO UPRIGHTS

STEP 9



LOCK CROSS BRACE TO UPRIGHTS

SWC PRE-INSTALLED

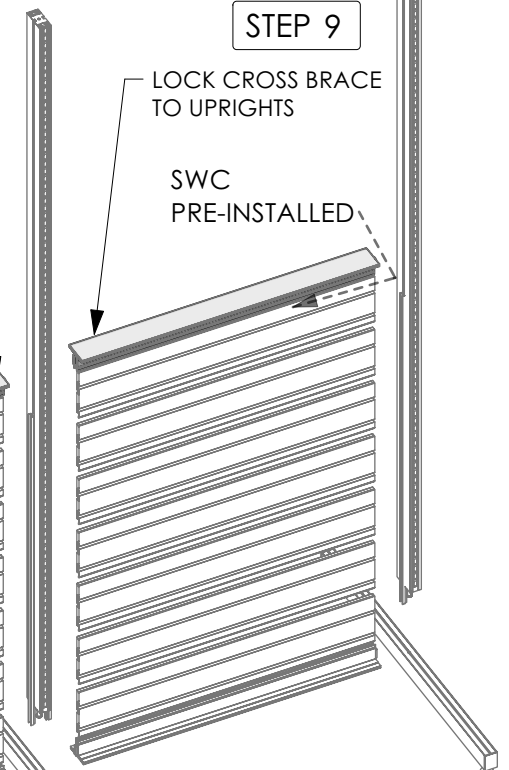
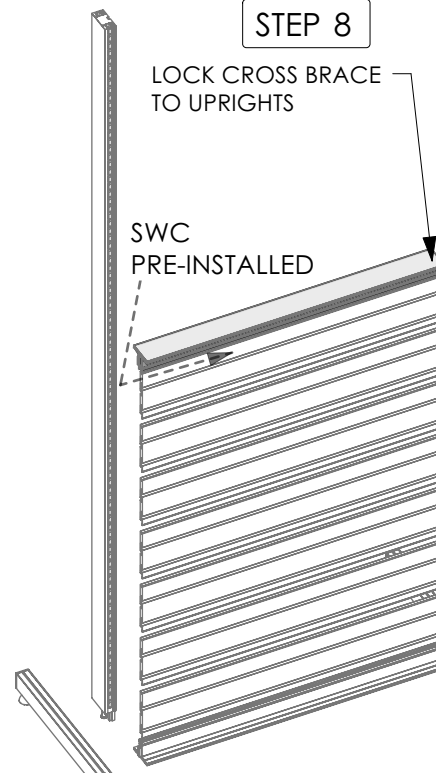
SWC PRE-INSTALLED



SETUP INSTRUCTIONS

QTY	IMAGE	DESCRIPTION
4		(39.26 w X 51.08 h total size) 35.26 w X 47.08 h finish size, Dye-sub print on Eclipse Blockout Stretch, single sided, sewn with FCE-2 silicone beading around perimeter & pull tab in bottom right corner (WITH 1/4" NOTCH LEFT & RIGHT BOTTOM HORIZONTAL SIDE CORNERS)
4		36in WIDE X 17.25in DEEP - DROP-IN BASE PAN

STEP 12

INSTALL GRAPHICS

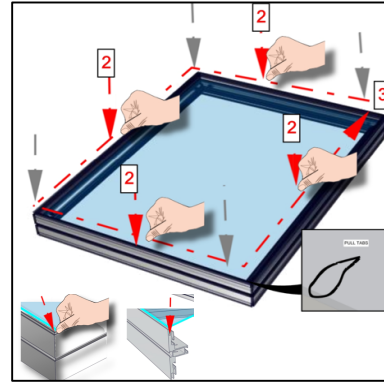
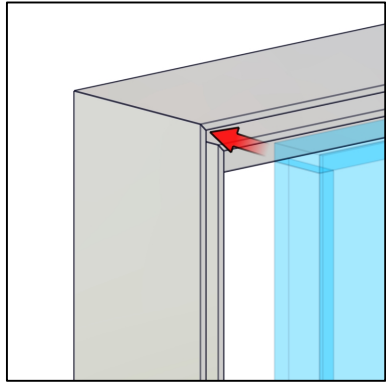

PRESS GRAPHIC INTO CORNERS

THEN PRESS ALONG THE PERIMETER EDGE

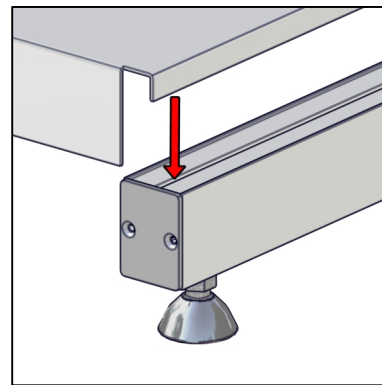
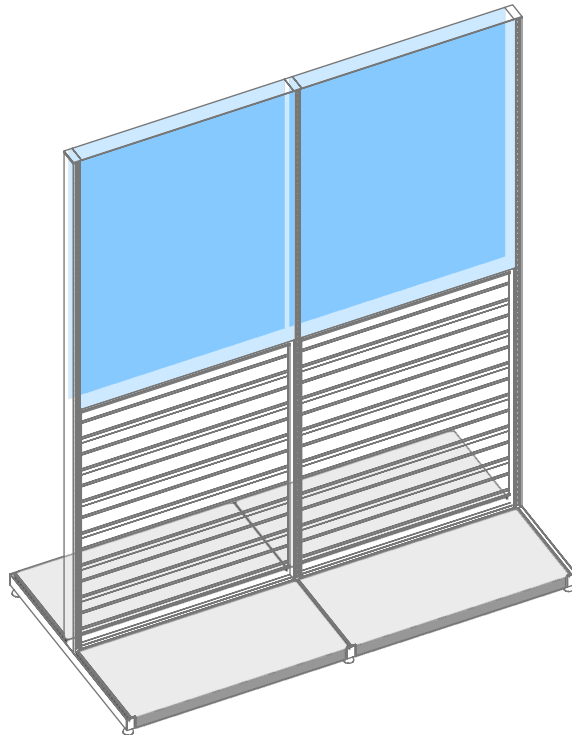



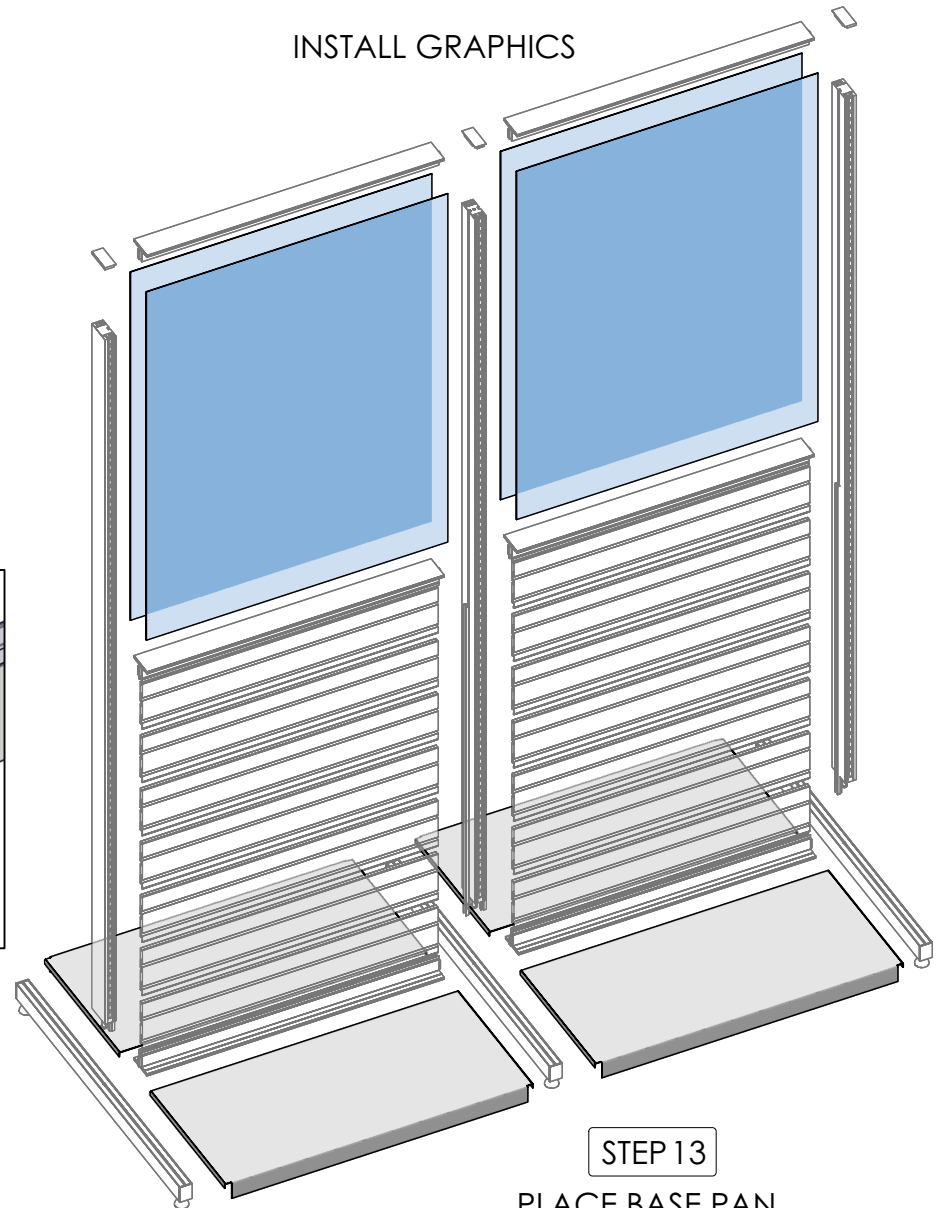

MFY-36-17-BASE-PAN







STEP 13

PLACE BASE PAN IN GROOVE(FOOT)

KIT Hardware BOM

ITEM	COMPONENTS	QTY	DESCRIPTION
	004-883	4	883MM (34.76in) OF SWC EXTRUSION
	004-1058	4	1058MM (41.65in) OF SWC EXTRUSION
	005-879	14	879MM (34.61in) LENGTH OF SLOTWALL EXTRUSION
	824-947	1	947MM (37.28IN) LEFT SUPPORT LEG
	824-947	1	947MM (37.28IN) MIDDLE SUPPORT LEG
	824-947	1	947MM (37.28IN) RIGHT SUPPORT LEG
	832-2350	1	2350MM (92.52in) MIDDLE UPRIGHT
	832-EC	1	7MM SEG PLASTIC END CAP FOR 832 EXTRUSION
	833-2350	1	2350MM (92.52in) LEFT UPRIGHT
	833-2350	1	2350MM (92.52in) RIGHT UPRIGHT
	833-EC	2	7MM SEG PLASTIC END CAP FOR 833 EXTRUSION
	835-883-01-01	6	883MM (34.76in) OF SINGLE SIDED SEG EXTRUSION -WITH CAM LOCKS BOTH ENDS
	MFY-BOLT-375-16-2.5	3	3/8-16 x 2.5"L bolt
	MFY-DB-36-17	4	36in WIDE X 17.25in DEEP - DROP-IN BASE PAN

KIT Graphics BOM

ITEM	COMPONENTS	QTY	DESCRIPTION
	MFY-DS-02-A-G	1	(39.26 w X 51.08 h total size) 35.26 w X 47.08 h finish size, Dye-sub print on Eclipse Blockout Stretch, single sided, sewn with FCE-2 silicone beading around perimeter & pull tab in bottom right corner (WITH 1/4" NOTCH LEFT & RIGHT BOTTOM HORIZONTAL SIDE CORNERS)
	MFY-DS-02-B-G	1	(39.26 w X 51.08 h total size) 35.26 w X 47.08 h finish size, Dye-sub print on Eclipse Blockout Stretch, single sided, sewn with FCE-2 silicone beading around perimeter & pull tab in bottom right corner (WITH 1/4" NOTCH LEFT & RIGHT BOTTOM HORIZONTAL SIDE CORNERS)
	MFY-DS-02-C-G	1	(39.26 w X 51.08 h total size) 35.26 w X 47.08 h finish size, Dye-sub print on Eclipse Blockout Stretch, single sided, sewn with FCE-2 silicone beading around perimeter & pull tab in bottom right corner (WITH 1/4" NOTCH LEFT & RIGHT BOTTOM HORIZONTAL SIDE CORNERS)
	MFY-DS-02-D-G	1	(39.26 w X 51.08 h total size) 35.26 w X 47.08 h finish size, Dye-sub print on Eclipse Blockout Stretch, single sided, sewn with FCE-2 silicone beading around perimeter & pull tab in bottom right corner (WITH 1/4" NOTCH LEFT & RIGHT BOTTOM HORIZONTAL SIDE CORNERS)