

# Vector Frame Kit 19

## VF-K-19

The innovative, contemporary and clean appearance of the Vector Frame™ line of exhibit kits will captivate your audience. Kits feature push-fit fabric graphics, easy-to-assemble extrusion frames, accent lighting, tables, counters, literature accessories, monitor mounts and interior LED edge lighting where indicated.

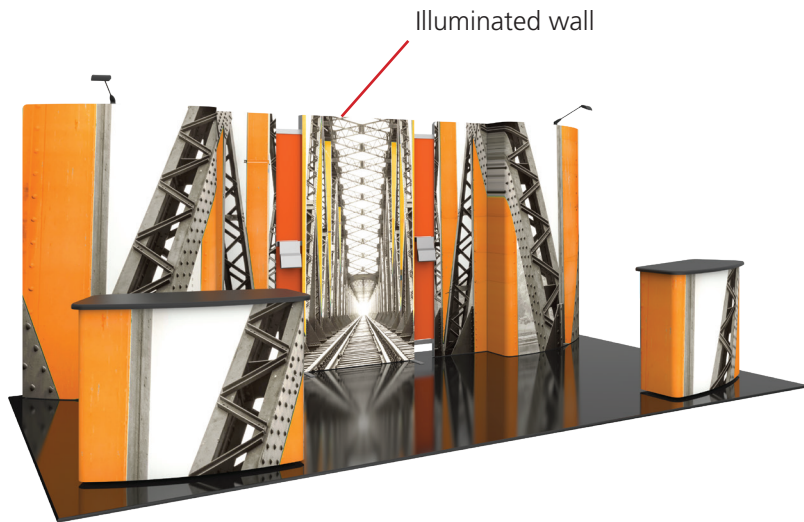

## features and benefits:

- 50mm and 100mm silver extrusion frames
- Illuminated graphic panel with interior LED lighting top and bottom
- Single-sided SEG dye-sublimated push-fit fabric graphics
- Kit includes aluminum frame, four fabric graphic panels, four rigid graphic panels, one illuminated graphic panel, two fabric graphic counters, two 120 watt spot lights, two literature pockets and five wheeled molded cases
- Lifetime hardware warranty against manufacturer defects

## dimensions:

### Hardware

### Graphic

Assembled Unit:  
232.2" w x 94.5" h x 25" d  
5898mm(w) x 2400mm(h) x 635mm(d)

Refer to related graphic template for more information.

Approximate weight:  
270 lbs / 123 kgs

Visit:  
[www.exhibitors-handbook.com/graphic-templates](http://www.exhibitors-handbook.com/graphic-templates)

### Shipping

## additional information:

Packing case(s):  
1 OCE  
1 OCH  
3 OCH2

Graphic material:  
Dye-sublimated fabric

Shipping dimensions:  
OCE: Expandable case length (l) may vary  
40" - 66" l x 18" h x 18" d  
1016mm-1677mm(l) x 458mm(h) x 458mm(d)

Counter top max weight = 100 lbs / 46 kgs

When included in a larger kit, a different packaging solution will be listed to accommodate all contents of the kit. Individual packaging no longer provided.

OCH:  
50" l x 26" h x 12" d  
1270mm(l) x 660mm(h) x 305mm(d)

### Tabletop Colors:

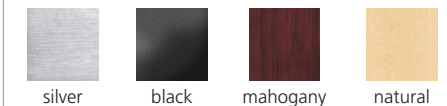

OCH2:  
52" l x 29" h x 15" d  
1321mm(l) x 737mm(h) x 381mm(d)

Approximate total shipping weight:  
379 lbs / 172 kgs

2 person assembly recommended:



We are continually improving and modifying our product range and reserve the right to vary the specifications without prior notice. All dimensions and weights quoted are approximate and we accept no responsibility for variance. E&OE. See Graphic Templates for graphic bleed specifications.

# Included In Your Kit

Tools, Components, & Connectors



5MM ALLEN-T x1



CB9-R x4

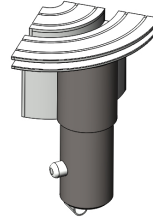

CB10-R x4

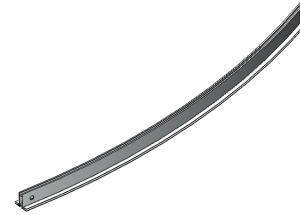

PHFC2-6R-45-L-L x4

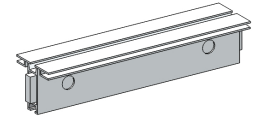

PHFC2-300-L-L x4

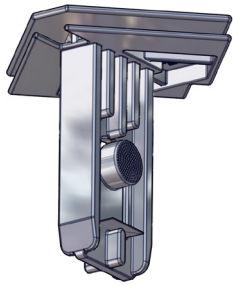

PMFC2-90-CAP x4

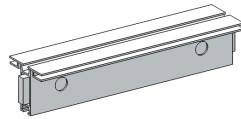

PHFC2-600-L-L x4

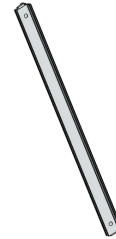

PHFC2-1155-L1-L x8

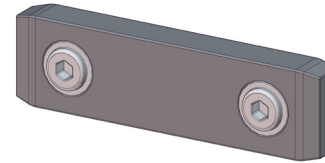

IB2 x8

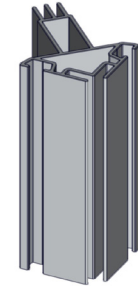

PMFC2-90-1193-L1-L1 x4



TUBE-30-1155 x4

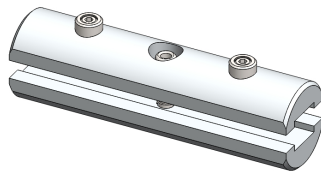

ES30 x2

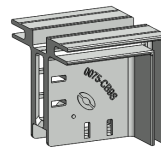

CB9-S x4

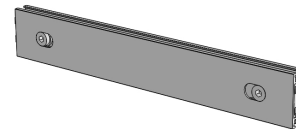

PH-250-S-S x8

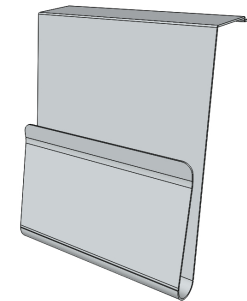

LN112-4 x2

# Included In Your Kit

Tools, Components, & Connectors

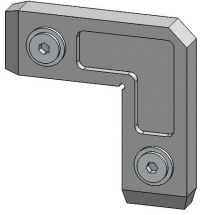

CB9 x4

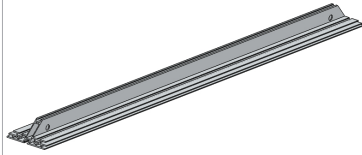

PHFC4-1200-MCB9-MCB9 x2

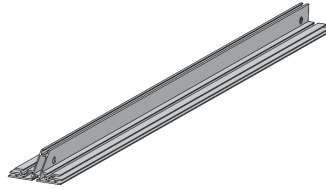

PHFC4-1200-L1-MCB9 x4

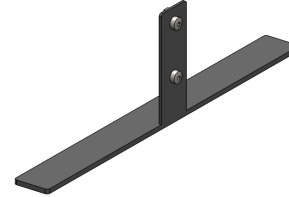

SW-FOOT-500-LN x2



LUM-200-ORL x2

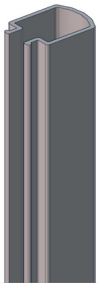

WME-1000 x2

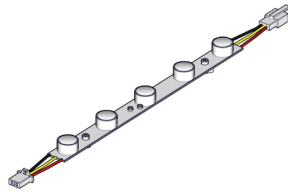

LED-WHT-DB-300 x6

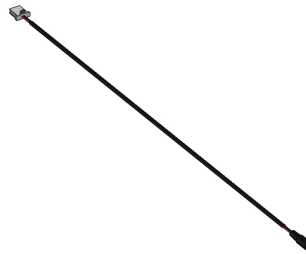

LED-DB-CL-DCJ-600 x1



LED-DB-CL-2400 x1

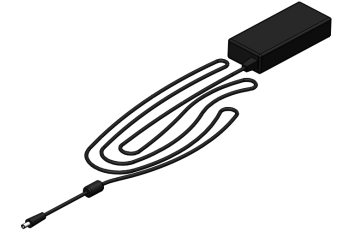

LED-DB-PWRSUPLY x1



LED-DB-PWRCORD x1



FABRIC STEAMER-ES x1



STEP STOOL-BLUE x1

# Included In Your Kit

Graphics



VF-19-A-G x1

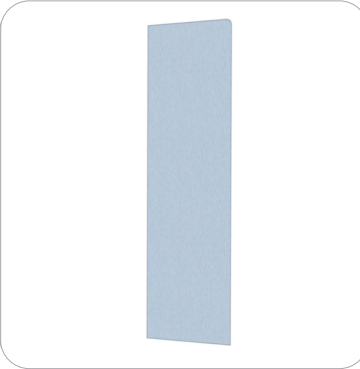

VF-19-B-G x1

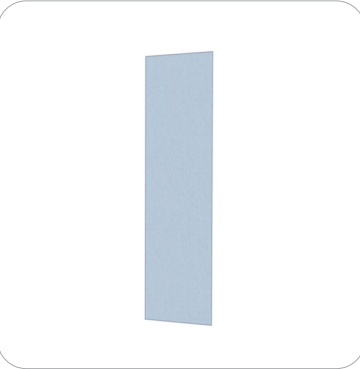

VF-19-C-G x1

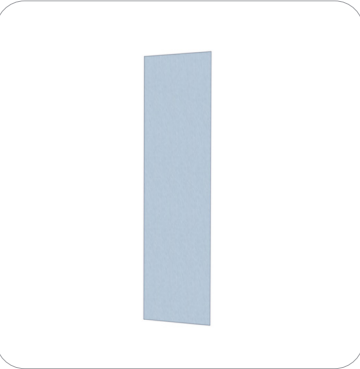

VF-19-D-G x1

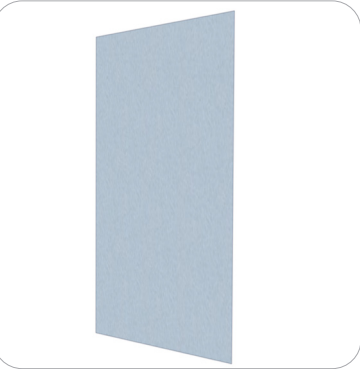

VF-19-E-G x1

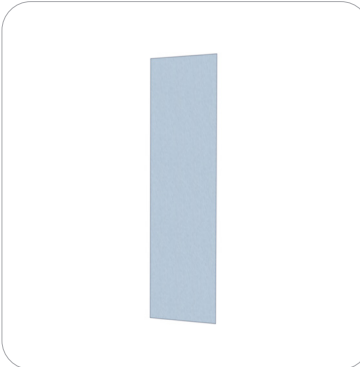

VF-19-F-G x1

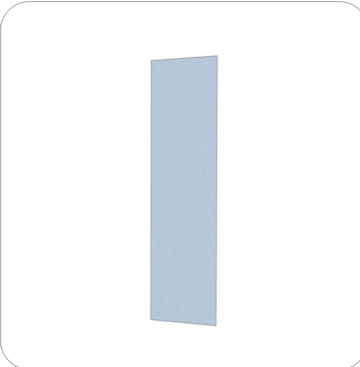

VF-19-G-G x1

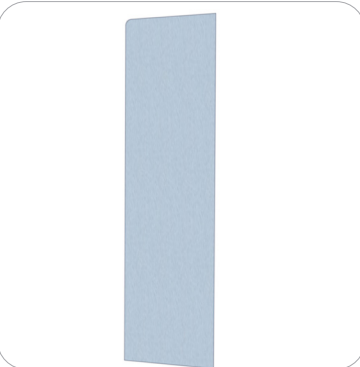

VF-19-H-G x1



VF-19-I-G x1



VF-19-J-G x1

Kits



VFC-02 x2

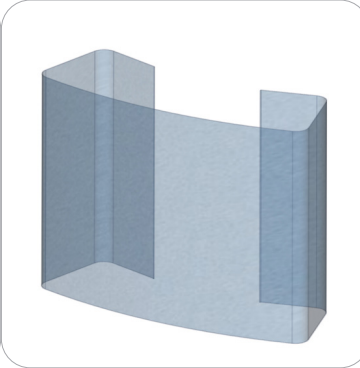

VFC-02-A-G x2



VFC-02-B-G x2

# Exploded View

VF-K-19

Section 1

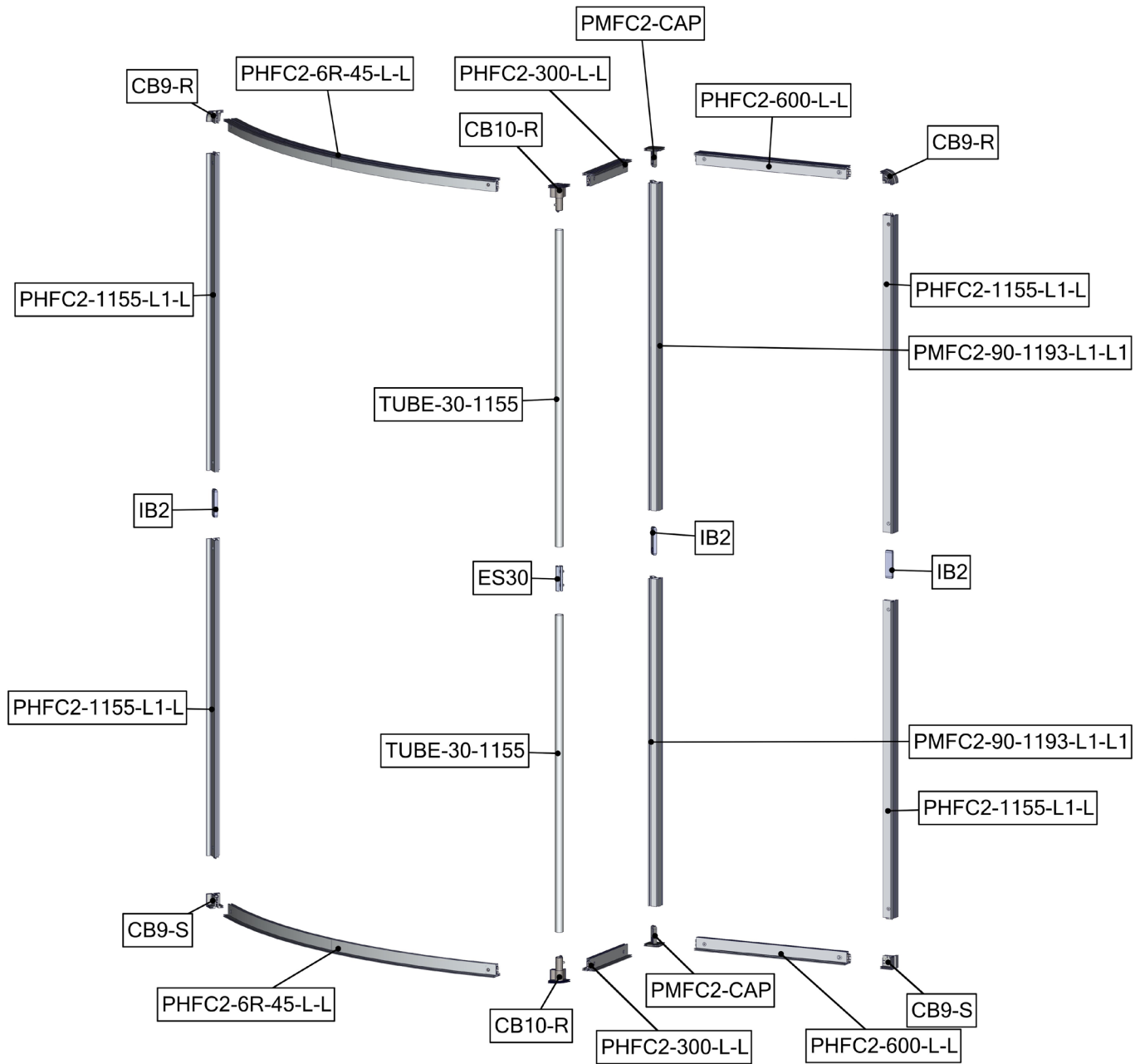

# Exploded View

VF-K-19

Section 2

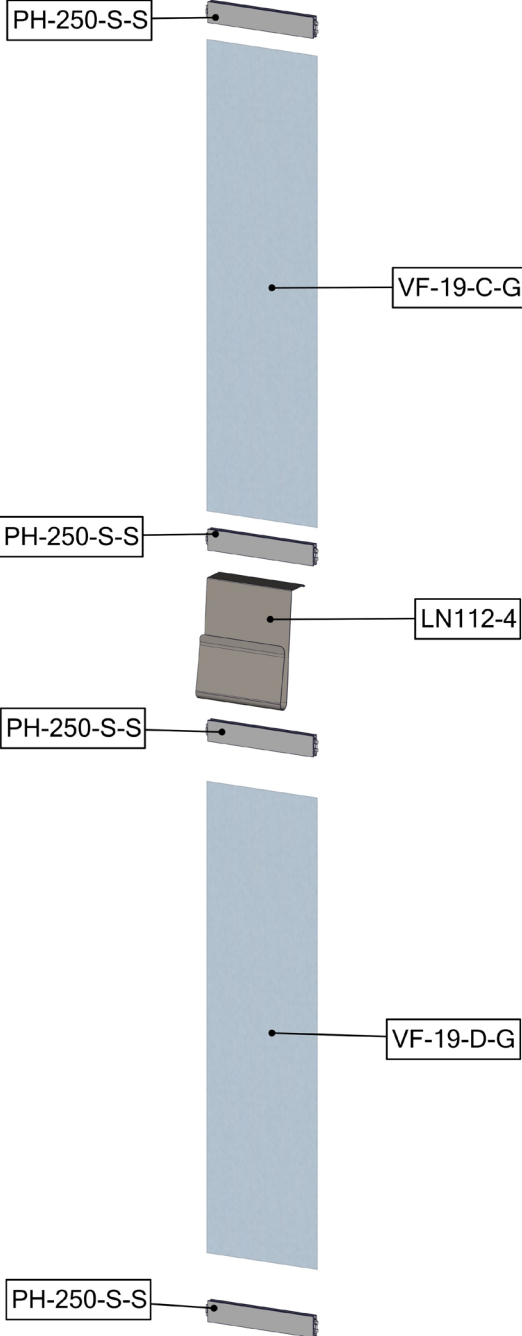

# Exploded View

VF-K-19

Section 3

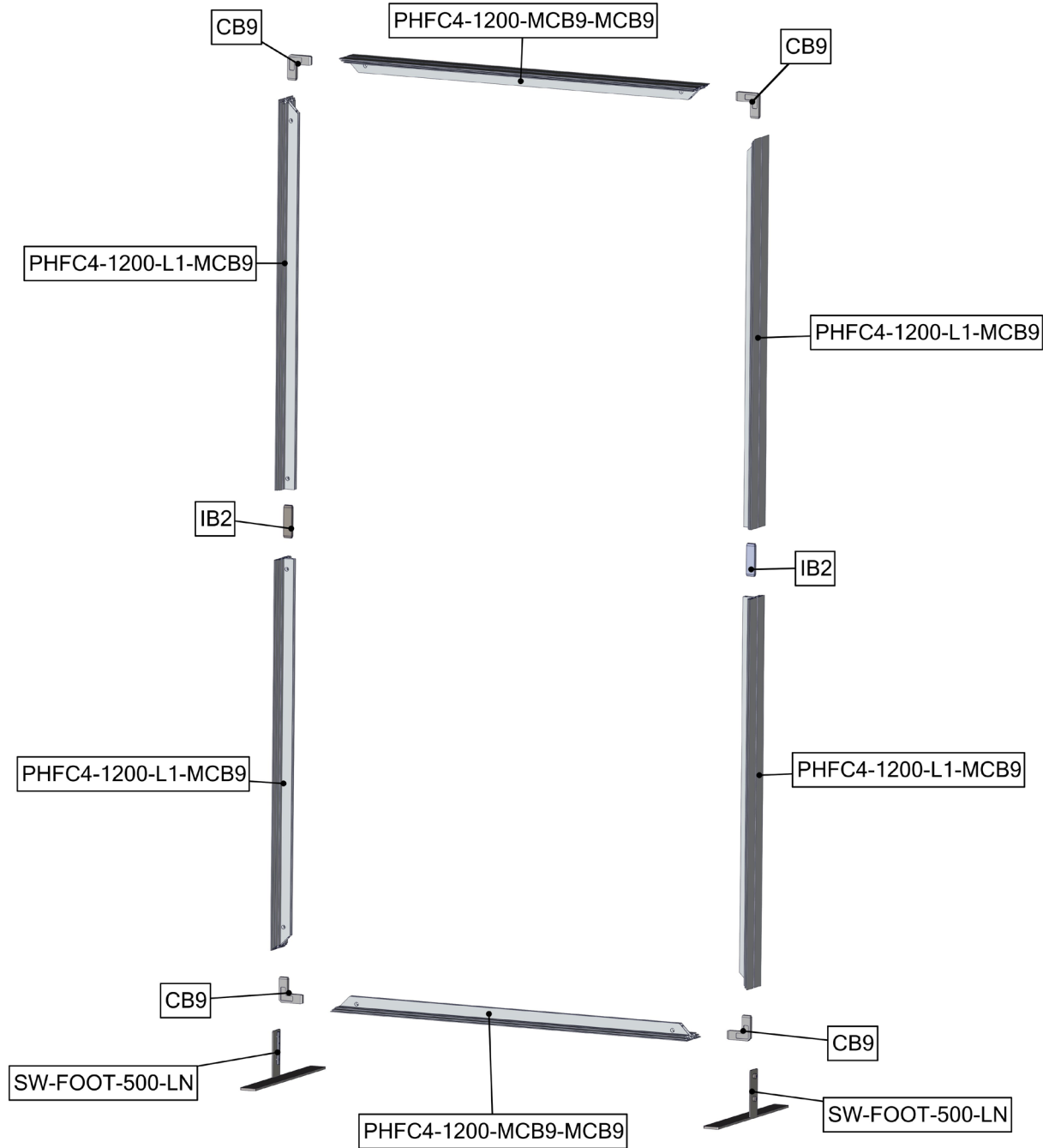

# Exploded View

VF-K-19

Section 4

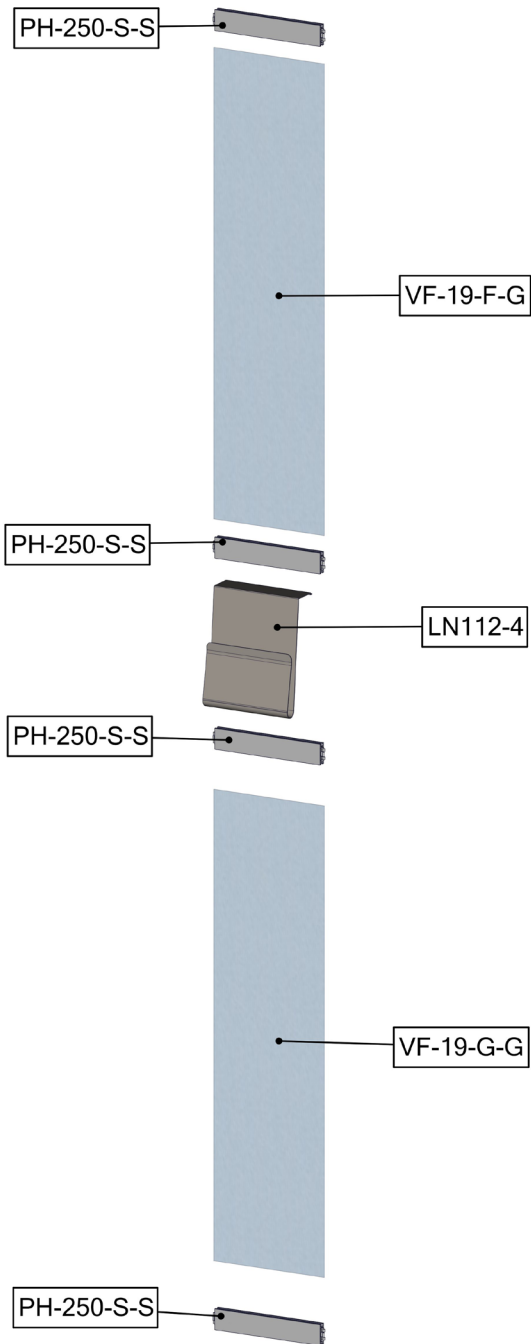



# Exploded View

VF-K-19

Section 5

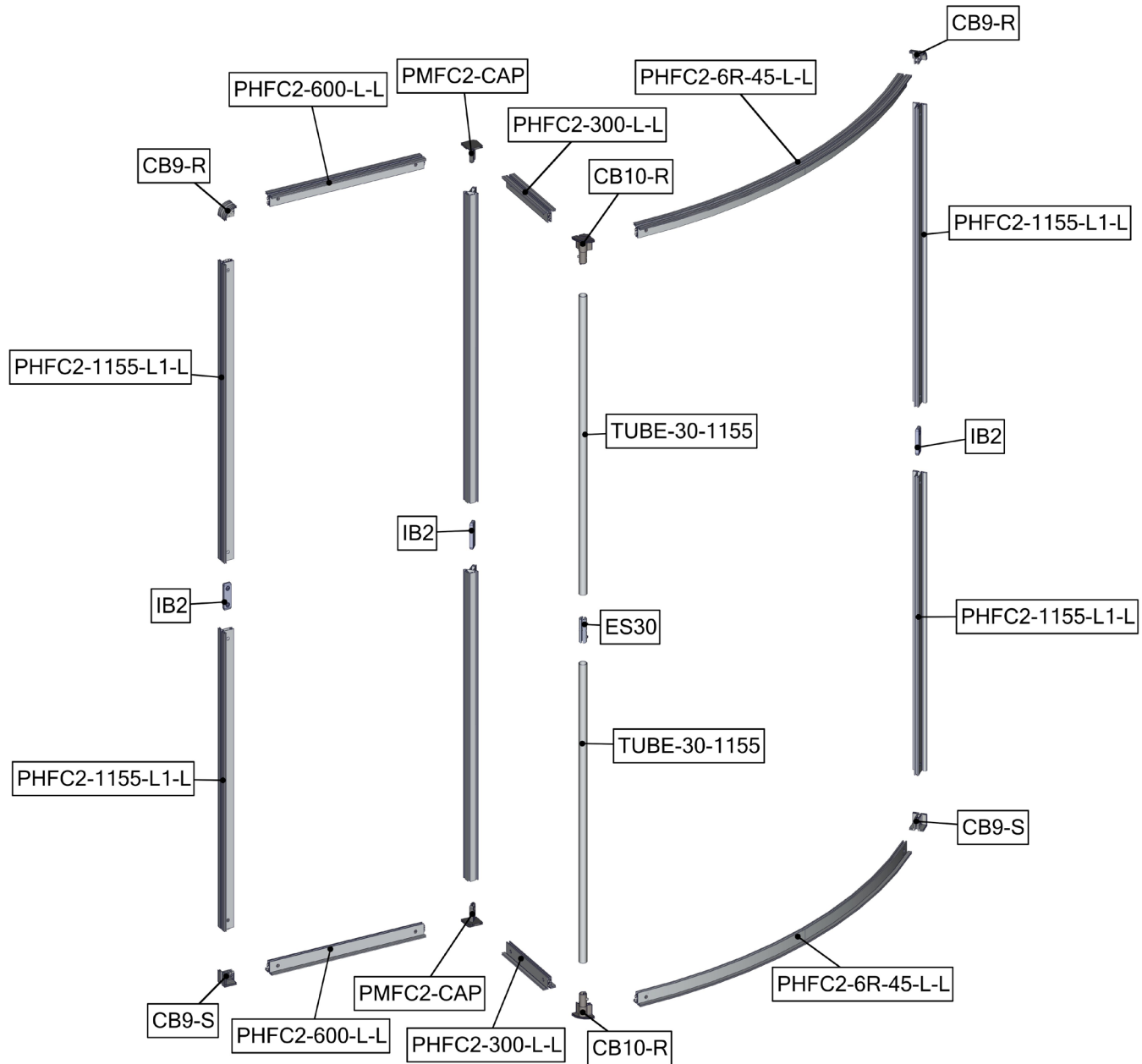

# Internal Lighting Diagram

VF-K-19

Section 3

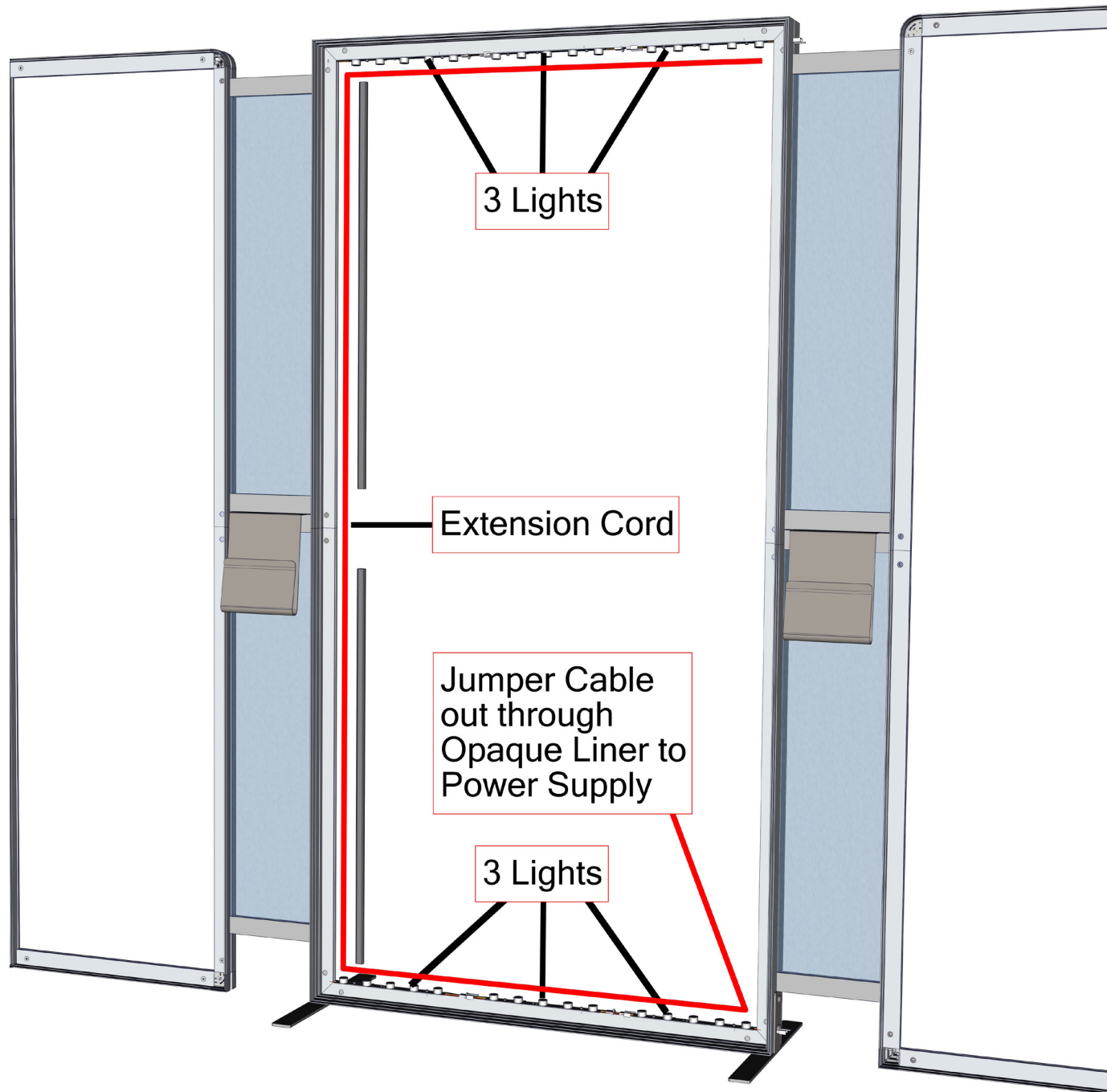

# Connection Methods

## Connection Method 1: PMFC2-90-CAP

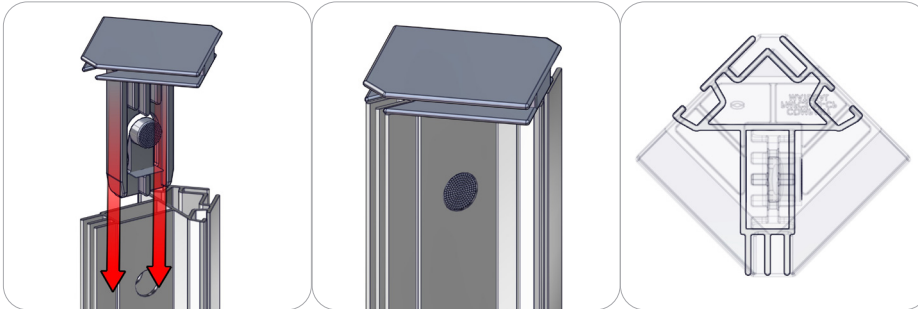

First, press button to insert the cap into the extrusion. The button will snap in place.

## Connection Method 2: PMFC2 / PHFC2



First, with the cam lock disengaged, place the cam lock teeth into the extrusion channel. Second, use the allen key tool to lock it in place. Make half turns clock-wise to engage the cam lock. Do not over tighten the lock buttons.

## Connection Method 3: CB9-R / CB9-S

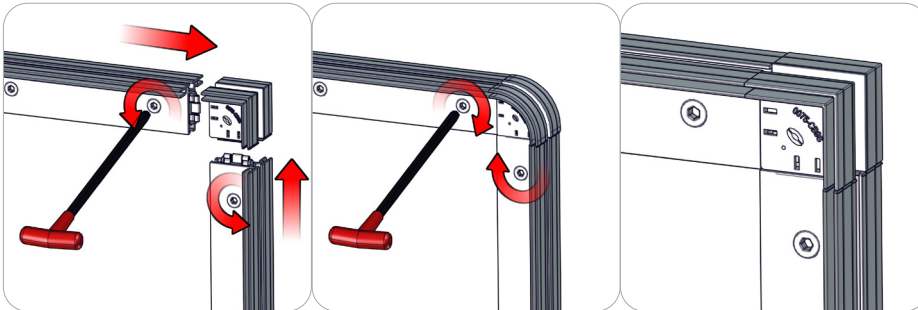

First, make sure the cam lock button is unlocked. Second, insert the cam lock teeth in to corner bracket channel. Third, tighten the cam lock button. Use the allen key tool to turn the lock buttons, make quarter turns and do not over tighten the lock buttons. Repeat for opposite end.

## Connection Method 4: ES30

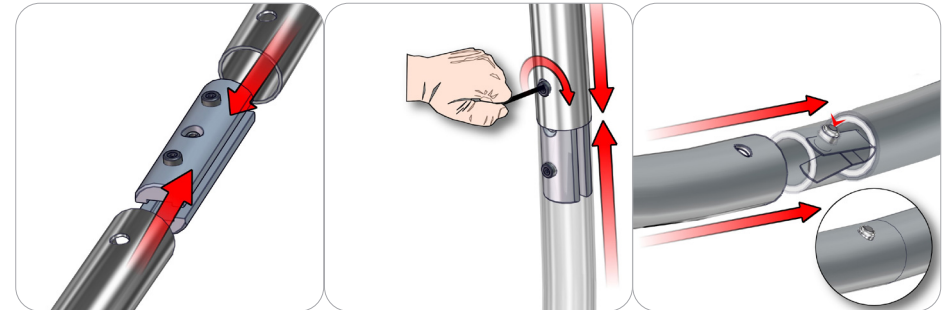

For spigot connections, compress the unlocked connector and slide into the tube lock access hole. Lock both screws carefully using your allen key tool. Be sure to lock securely, but do not over tighten. For snap button connections, locate the snap button on the connector or swage tube. Locate the hole on the corresponding tube. Press the snap button with your thumb and slide the tube and connector together so that the snap button snaps fully into the lock hole. To disassemble, press the snap button and pull apart.

# Connection Methods

## Connection Method 5: IB2

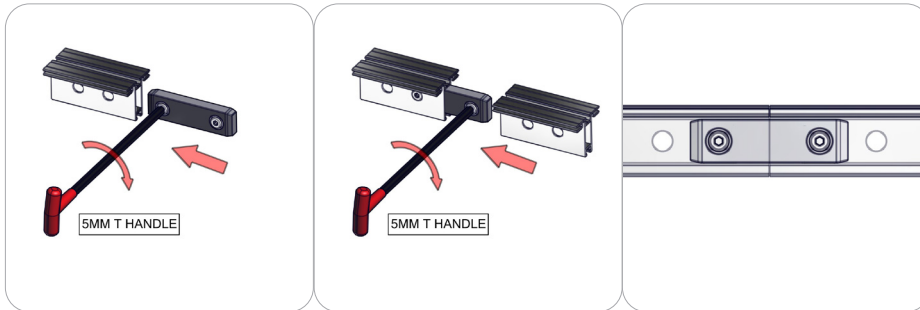

First, insert the in-line connector into the extrusion while holding in the lock button. Then, slide the next extrusion onto the same in-line connector again holding in the lock button. Finally, use the provided allen key to lock the in-line connector in place. Use the allen key tool to turn the lock buttons, make quarter turns and do not over tighten the lock buttons.

## Connection Method 6: CB9

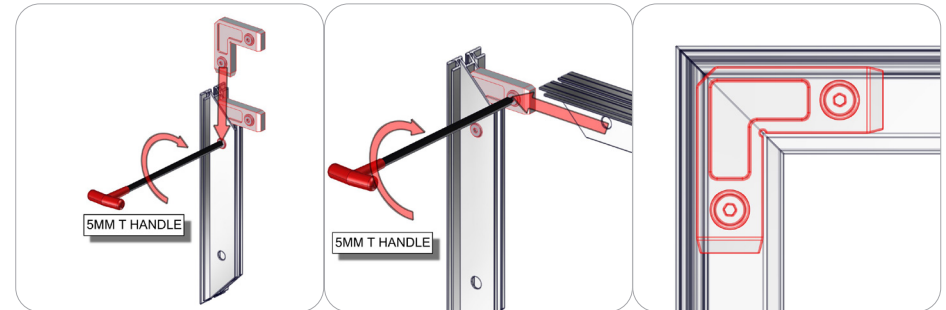

First, insert the corner connector into the extrusion while holding in the lock button. Then, slide the next extrusion onto the same corner connector again holding in the lock button. Finally, use the provided allen key to lock the corner connector in place. Use the allen key tool to press the lock buttons, make quarter turns and do not over tighten the lock buttons.

## Connection Method 7: SW-FOOT-300/500/650

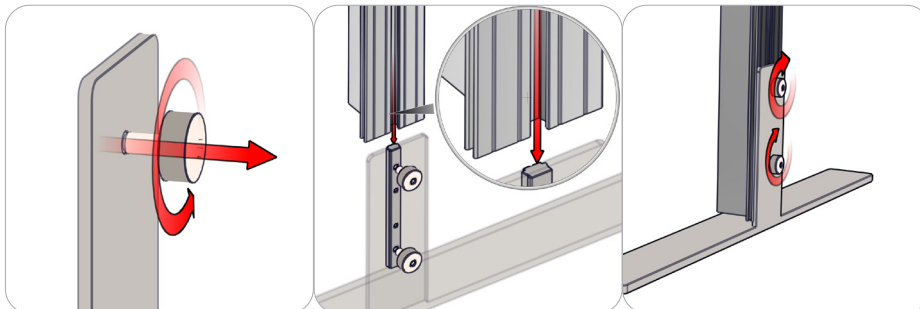

First, loosen the thumb screws and channel bars on the stabilizing bases. Do not disassemble them. Second, slide channel bars into the frame channel flush with the base of the frame. Finally, tighten the thumb screws and channel bars securing the attachment.

## Connection Method 8: LUM-200

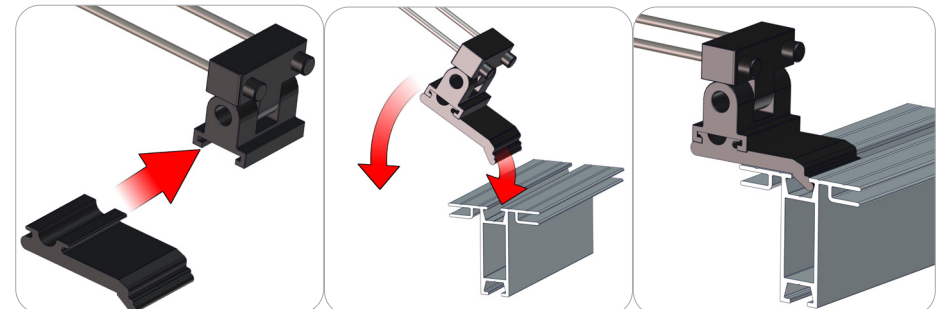

First, slide the light clip into the dove tail end of the spot light. Second, rest the light clip into the extrusion channel. Make adjustments to the spot light if necessary.

# Connection Methods

## Connection Method 9: CB10-R / PHFC2

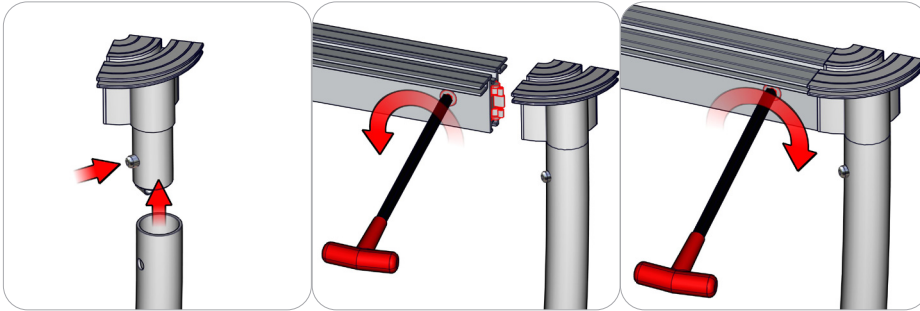

First, press and hold the snap button while you slide it into the tube. The snap button connection is secure when it protrudes through the tube hole. Second, using the allen key tool, disengage the cam lock in the extrusion end and place its teeth into the CB10-R channel. Third, with the cam lock teeth in the channel, use the allen key tool to engage the cam lock. Make a half turn to lock, do not over tighten. Repeat for opposite end.

## Connection Method 10: Graphic Application

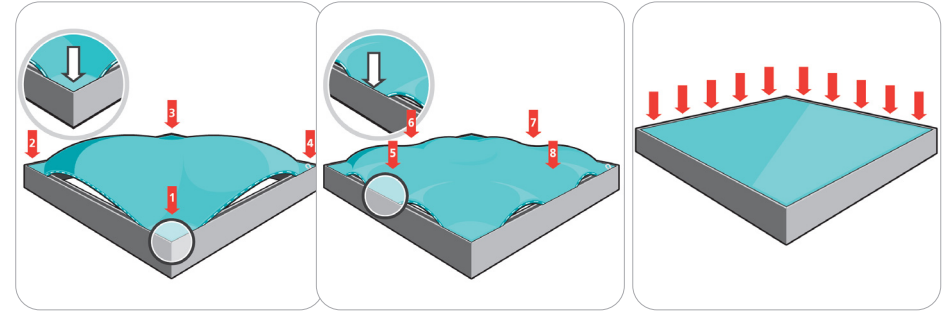

First, insert the silicone edge frame corners into the frame graphic channel (points 1 through 4). Second, insert the silicone edge frame sides into the frame graphic channel (points 5 through 8). Third, push the remaining silicone edge fabric into the frame graphic channel. Similar setup is recommended for the opaque liner. To remove these panels, simply pull the loop tag sewn near a corner.

## Connection Method 11: LN112-4 / PH

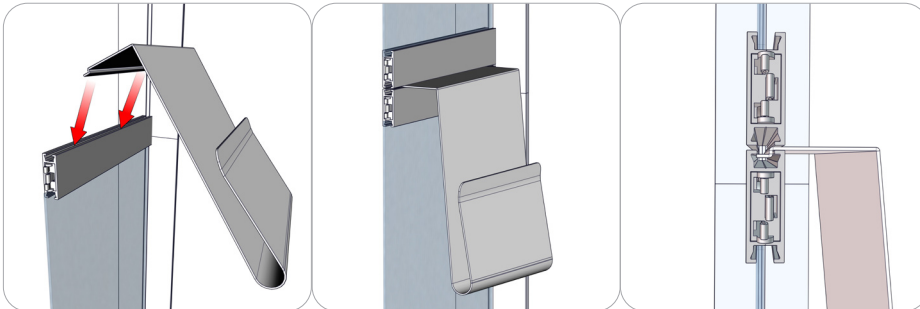

First, have a PH series profile or smaller extrusion with its channel facing up; lock it in place to hold the literature pocket. Second, rest the literature pocket flange into the extrusion top channel. Third, your kit may feature a second extrusion to lock right above the literature pocket.

## Connection Method 12: PH-L / PH-S / PHFC2 / PHFC4

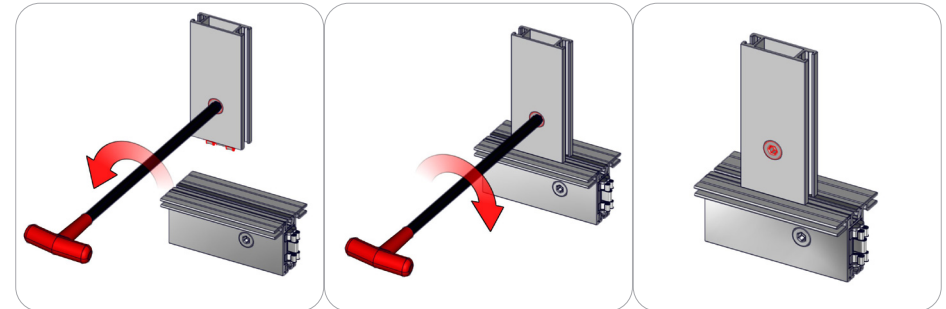

First, with the cam lock disengaged, place the cam lock teeth into the extrusion channel. Second, use the allen key tool to lock it in place. Make half turns clock-wise to engage the cam lock. Do not over tighten the lock buttons.

# Connection Methods

## Connection Method 13 (Part 1): LED-WHT-DB-300

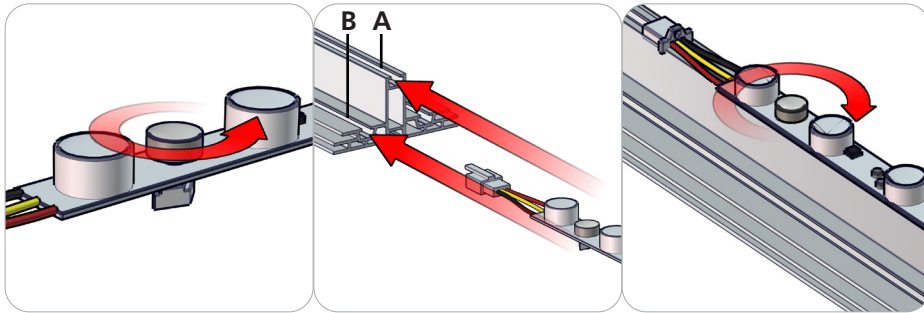

For single sided graphics, it is recommended to attach the light strips into PHFC4 channel (B). For double sided graphics, it is recommended to attach the light strips into PHFC4 channel (A). Loosen the thumb screws and diamond toggles on the light strips. Notice the male and female plugs for arranging them in series. Spread the lights out evenly on the frame channels desired. Lightly tighten the thumb screws, allowing them to slide and adjust for connections even distances apart.

## Connection Method 13 (Part 2): LED-WHT-DB-300

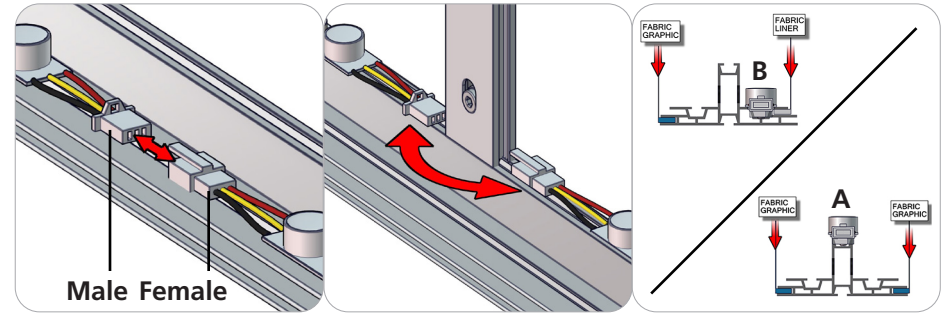

Note: Each power supply can light up to 9 light strips; more details on power supply cords later. With the male and female plugs in series, connect the **LED-WHT-DB-300's** end to end. You can also connect these lights around a vertical extrusion spreader and continue the series. You may loosen the thumb screws to adjust the location of the light strips to simplify connections and reduce shadowing.

## Connection Method 13 (Part 3): LED-WHT-DB-300 LED-DB-DCJ-600 / LED-DB-PWRSUPLY / WME

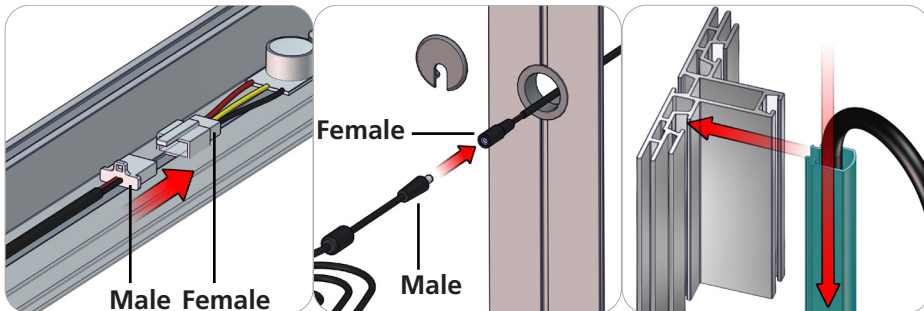

Note: Each power supply can light up to 9 light strips. Depending on the size of your frame and number of lights; you may have to split the power supplies evenly for maximum lighting effect. Connect the male end of the **LED-DB-DCJ-600** power cord to the female end of the light strip series. Run the female end of **LED-DB-DCJ-600** out through the PHFC4 grommet hole. Connect the male end of the **LED-DB-PWRSUPLY** to the power cord female end. Use wire management extrusion (**WME**) to organize the power cords inside of the frame. Test the **LED-DB-PWRSUPLY** out to a power outlet.

## Connection Method 13 (Part 4): Internal Lighting Components

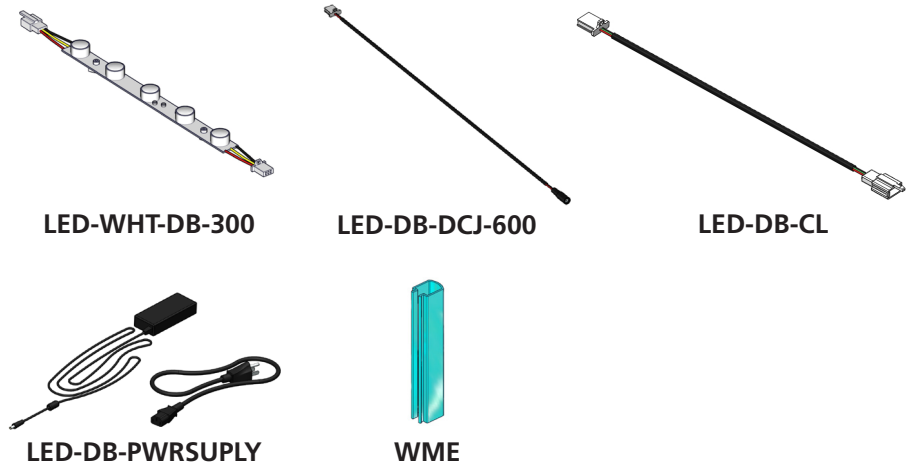



# Kit Assembly

## Step by Step

### Step 1.

Locate all components necessary to assemble frame section 1. Place the components in the order as shown in Exploded View section 1.

Reference Connection Methods 1-5 and 9 for more details.

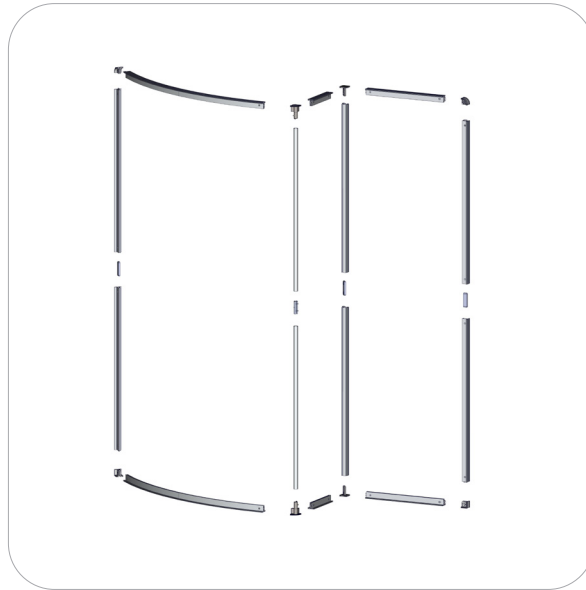
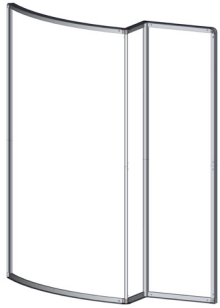

### Step 2.

Locate all components necessary to assemble frame section 3. Place the components in the order as shown in Exploded View section 3.

Reference Connection Methods 5-7 for more details.



### Step 3.

Locate all components necessary to assemble frame section 5. Place the components in the order as shown in Exploded View section 5.

Reference Connection Methods 1-5 and 9 for more details.

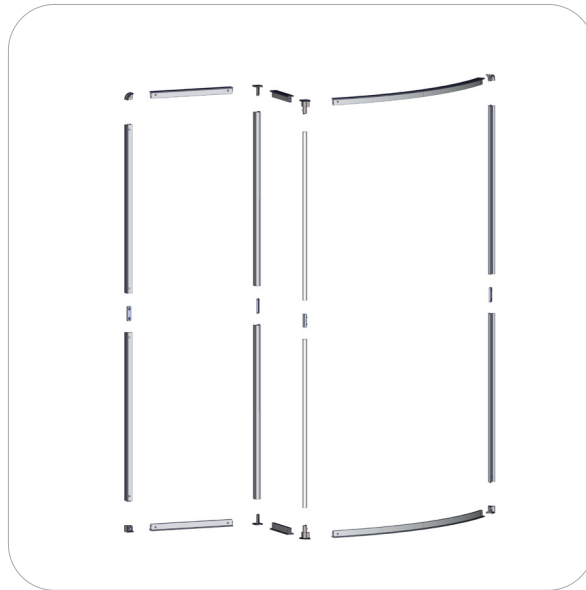
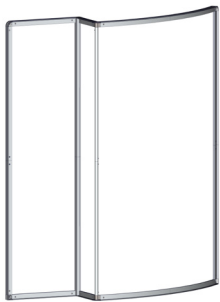

### Step 4.

Locate all components necessary to assemble frame section 2. Place the components in the order as shown in Exploded View section 2. Combine sections 1, 2 and 3.

Reference Connection Method 11 and 12 for more details.

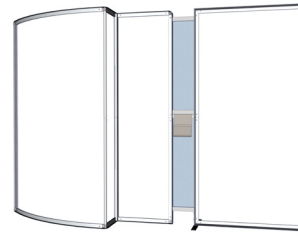

# Kit Assembly

## Step by Step

### Step 5.

Locate all components necessary to assemble frame section 4. Place the components in the order as shown in Exploded View section 4. Combine sections 3, 4 and 5.

Reference Connection Method 11 and 12 for more details.

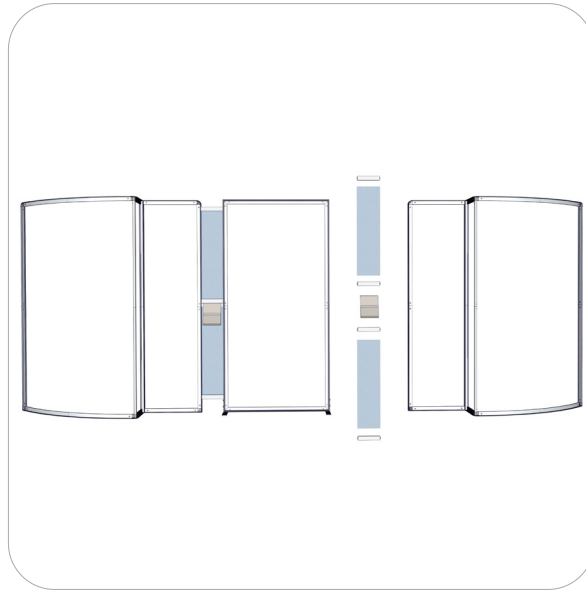
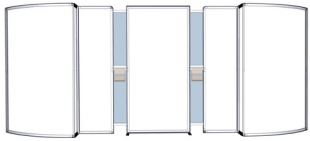

### Step 6.

Gather the components necessary for the internal lighting setup to your light box section 3. Assemble in the order the Internal Lighting Diagram instructs. Test the light connections.

Refer to Connection Method 13 for additional information.

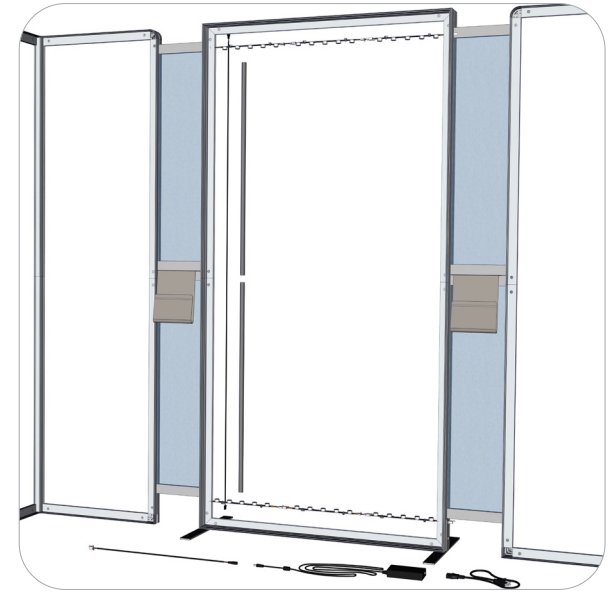
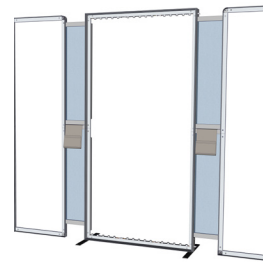

### Step 7.

Locate your silicone edge graphic panels and opaque liner. Push the silicone edges of the graphic panel into the fabric channels of the extrusion frame perimeter. Push the silicone edges of the opaque liner into the fabric channels of the extrusion frame perimeter.

Refer to Connection Method 10 for additional information.

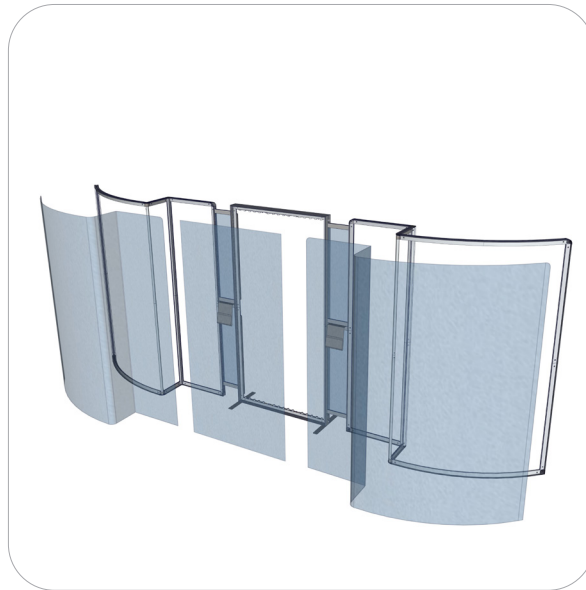
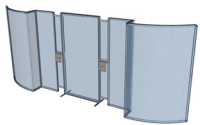

### Step 8.

Gather the two spot lights, attach them to the top of the frame.

Refer to Connection Method 8 for additional information.

Setup is complete.

